

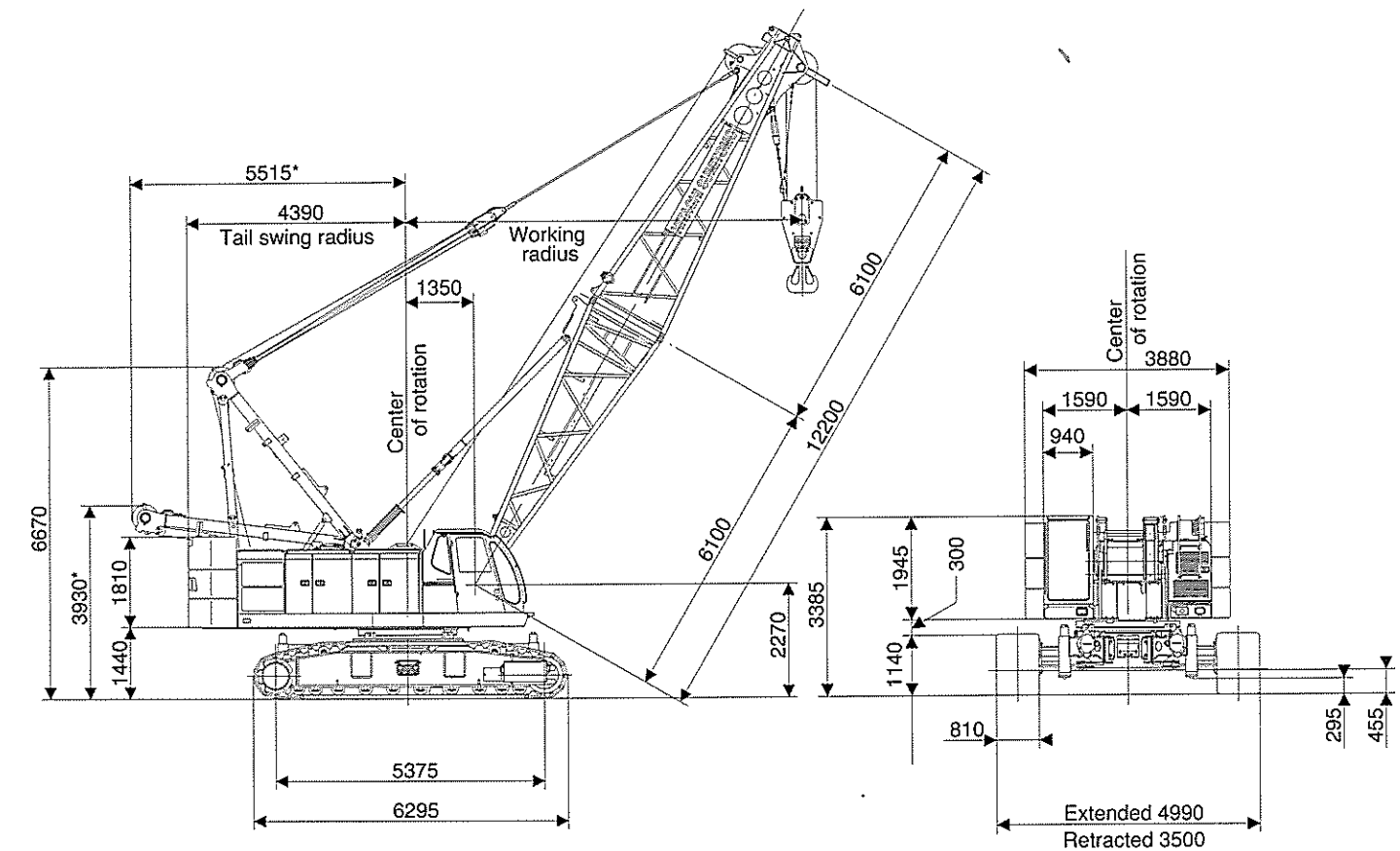

SCX900HD-1

Hydraulic Cable Excavator
& 90-M ton Crawler Crane

General Dimensions:



Notes: 1. The above general arrangement is under liftcrane application with 12.20m basic boom and optional 90t hook block.
2. The figures with an asterisk mark (*) show the dimensions when A-frame gantry is lowered in case that counterweight is being assembled.

Hitachi Sumitomo Heavy Industries Construction Crane Co., Ltd.

12-14, Ueno 7-chome, Taito-ku, Tokyo 110-0005, Japan
Phone: 81-3-3845-1387 Facsimile: 81-3-3845-1394

- We are constantly improving our products and therefore reserve the right to change designs and specifications without notice.
- Units in this specification are shown under International System of Units; the figures in parenthesis are under Gravitational System of Units as old one.

Address Inquires to:

(in mm)

1st Edition

Specifications

HITACHI SUMITOMO

SCX900HD-1

Basic Machine

Superstructure

UPPER REVOLVING FRAME:

All-welded, precision machined, robust construction. A machined surface provided for mounting load hoist and boom hoist assemblies, and mounting itself on turntable bearing.

TURNTABLE BEARING WITH INTERNAL SWING GEAR:

Single shear ball type; inner race of turntable bearing with integral, internal swing (ring) gear bolted to carbody frame, and outer race of turntable bearing bolted to upper revolving frame.

CONTROL SYSTEM:

System contains one set each of duplicate and triplicate tandem valves which direct oil to various machine function and are actuated by control levers via remote controlled hydraulic servo for all motions. Working speeds can be precisely controlled by motorcycle type throttle and pilot-operated arm chair single axis control levers in cooperation with "SC" controller that varies engine rpm and hyd. pump discharge simultaneously, or varies just hyd. pump discharge while keeping engine rpm. System also takes unique EEP SA (Electrical Engine Pump Sensing Analyzer) to maximizes drum horsepower, and reduces horsepower loss with eliminating the possibility of engine stall.

Pump control system — By "SC" controller that provides two modes of engine-pump control.

MODE I:

The SC Controller is normally programmed to vary the engine speed and pump discharge simultaneously. Simply twisting the grip advances the engine to maximum speed and the hydraulic pumps to maximum flow at the same time. This mode is suitable to precision crane work.

MODE II:

By activating a switch, it is able to vary just the pump discharge by means of the grip throttle, while keeping engine speed fixed. Mode II is convenient for duty cycle works such as dragline operation, where the engine is normally run at full throttle.

HYDRAULIC SYSTEM:

System provided with three variable displacement axial piston pumps and one fixed displacement duplicate tandem gear pump for both independent and combined operations of all functions. Gear pump also used for system valves and cylinder controls.

Main/aux. crane hoist motors — Variable displacement axial piston motor with counterbalance valve.

Boom hoist motor — Axial piston type with counterbalance valve and spring-applied/hydraulically released multiple wet-disc type automatic brake.

Third drum motor — Optional extra; axial piston type with counterbalance valve;

Swing motor — Two; axial piston type with spring-applied/hydraulically released multiple wet-disc type manually controlled brake.

Travel motors — Shoe-in design; axial piston motor with brake valve and spring-applied/hydraulically released multiple wet-disc type automatic brake.

Oil cooler — Located at right-rear of machinery room as separated from engine radiator together with an independent autocooling fan for better cooling efficiency and heat balance.

Independent hyd. circuits — Available in between hydraulic circuits of P1 main pump and rear main drum winch motor, and between P2 main pump and front main drum winch motor.

Hydraulic oil reservoir — 410 liters capacity.

LOAD HOIST ASSEMBLY:

Front and rear main operating drums driven by independent hydraulic motor of bi-directional, variable displacement axial piston motor through 2-stage planetary reduction gear units powering the rope drum in either direction for hoisting and lowering load. Each of drum sized in same dimension.

Clutches — Internal expanding, self-adjusting, mono-band design with non-asbestos lining; spring-applied, power hydraulically released.

Brakes — External contracting band type with non-asbestos lining and 1,270mm dia. by 170mm wide brake drum each bolted to drum lagging; hydrostatically-operated by foot pedal with booster, but no brake links. Two brake modes are available; for crane operation, automatic brake, spring-applied, power hydraulically released is applied when control lever is in neutral position, and for bucket operation, free-fall is available in the above control lever position.

A forced aircooling system — Available on both front and rear main brake drums in order not to rise brake drum surface temperature for better operation efficiency in case that hard braking action is required when duty cycle operation.

Drums — One piece, spiral grooved lagging (as std. for dragline application)/parallel grooved lagging (as std. for liftcrane & clamshell applications) with locking ratchet wheel cast integral; mounted on drum shaft through anti-friction bearings. Available to wind up 42.4m long cable of 28mm dia. at drum 1st layer.

Drum locks — Electrically operated pawl.

Drum rollers — Optional extra; available for right cable winding onto drums.

BOOM HOIST ASSEMBLY:

Driven by bi-directional, axial piston hydraulic motor through 2-stage planetary reduction gear unit powering the rope drum in either direction for hoisting and lowering boom.

Brake — Spring-applied, power hydraulically released multiple wet-disc type automatic brake.

Drum — One piece, parallel grooved lagging with locking ratchet wheel cast integral; mounted on drum shaft through anti-friction bearings.

Drum lock — Power hydraulically operated pawl.

THIRD DRUM WINCH MECHANISM:

Optional extra; driven by bi-directional, axial piston hydraulic motor through planetary reduction gear units powering the rope drum in either direction for hoisting and lowering load. This is available for auxiliary lift.

Clutches — Internal expanding, self-adjusting, mono-band design with non-asbestos lining; spring-applied, power hydraulically released.

Brakes — External contracting band type with non-asbestos lining; operated by power hydraulically assisted foot pedal with locking latch. Not only automatic brake but also free-fall modes are available.

Drums — One piece, parallel grooved lagging with locking ratchet wheel cast integral; mounted on drum shaft through anti-friction bearings.

Drum locks — Electrically operated pawl.

SWING:

Driven by two units of bi-directional, axial piston hydraulic motors through 2 sets of planetary reduction gear unit powering swing pinion. Swing pinion meshes with internal teeth of swing (ring) gear of turntable bearing inner race.

Brakes — Spring-applied, power hydraulically released multiple wet-disc type; provided on each of hydraulic motor.

Swing speed control — Max. swing speed can be tuned according to arbitrary value that is electrically controlled by dialing, and then varies pump discharge.

Lock — Mechanically operated drop pin.

Speed — 2.9min.⁻¹ <2.9rpm>

GANTRY:

A-frame type; raised and lowered by power hydraulic cylinders.

OPERATOR'S CAB:

940mm wide; acoustically treated, all new stamped, automotive type, full-vision, cushion rubber mounted, well-ventilated, full compartment, roomy operator's cab with large curved green-tinted safety glass front window; provided with an arrangement of "SC" control/swing lever, armchair control station, sunvisor, sunshade, rear-view mirrors, dual intermittent type window shield wipers with washer on both front and roof windows, and roll-down window on sliding door.

Instrument panel — Contains engine monitoring lamps, display panel of SML-10 Load Moment Limiter (as std. for liftcrane version), and other necessary controllers and switches.

Operator's seat — Full adjustable reclining seat with both R/H and L/H side arm rests.

Stone guard — Optional extra; stainless steel-make. This is available for operator's cab protection from outside obstacles.

Air-conditioner — Optional extra; built-in type full air-conditioning.

Heater — Optional extra; hot water type.

Electric cab fan — Optional extra; wind-direction adjustable type.

Operator's cab sidestep — Optional extra; available for access ease to operator's cab.

AM/FM radio — Provided as std. with clock.

Fire extinguisher — Optional extra; powder type with 1kg capacity.

MACHINERY CAB:

Equipped with hinged doors on both sides for machinery access and inspection; tape-type non-skid material applied to the roof.

CATWALKS:

Optional extra; hitched in place along both sides of machinery cab.

FAIRLEAD:

Std. for dragline application; full-revolving, heavy duty type with two each of guide roller and sheave for right winding of dragline inhaul cable into front main drum.

HYDRAULIC TAGLINE WINDER:

Std. for clamshell application; provided in front of upper revolving frame, and this is available for preventing a shake of suspended load like clamshell bucket by an 10mm dia. tug cable with light force.

COUNTERWEIGHTS:

Weighs 28.8ton with a 3-cast iron block, removable, corner-rounded design. Three blocks consist of "A" (9,500kg), "B" (9,800kg) and "C" (9,500kg).

AUXILIARY WEIGHT:

Weighs 1.5ton. Mounted on part of optional 3rd drum location; if 3rd drum optionally required, no this 1.5ton weight is required.

ELECTRICAL SYSTEM:

24-volt negative ground system; provided with two maintenance free 12-volt batteries.

LIGHTING SYSTEM:

Includes following lights.

- Two 70 W working lights;
- One 10 W interior cab light.

POWER UNIT:

Make & Model	Mitsubishi 6D24-TL*
Type	Water-cooled, 4-cycle, direct injection, turbo-charged, diesel w/automatic cooling fan
No. of Cylinders	Six (6)
Bore & Stroke	130 mm x 150 mm
Displacement	11,945 cc
Rated Output	235 kW/2,000 min ⁻¹ < 320 ps/2,000 rpm >
Maximum Torque	1,245 N · m/1,400 min ⁻¹ < 127 kgf-m/1,400 rpm >
Fuel Tank	500 liters

***Note:**

6D24-TLU2E

EU Emission Regulations for Off-road Diesel Engines- Stage 2.

6D24-TLE2A

Japanese Emission Standards For Diesel Construction Equipment Stage 2.

Undercarriage

CARBODY FRAME:

All-welded, precision machined, box type construction; provided with longer axle with folding type tips reaching up to axle box end of crawler side frame for better fitting between axle and crawler side frames. A machined surface provided for mounting turntable bearing.

CARBODY JACK-UP DEVICE:

Contains four hydraulic jack cylinders attached on carbody jack cylinder beams for extending/retracting, and disassembling/assembling ease of crawler side frames.

Pontoon — All-welded construction; four pontoons each stored at an inside part of jack cylinder beams.

CRAWLER SIDE FRAMES:

All-welded, box type construction, precision machined; positioned on axle beam, and held in place by plate links.

Removal cylinders — Available for extending/retracting side frames, and assisting in removing side frames.

Crawler side steps — Provided at both ends of the frames for easy access to superstructure.

DRIVE SPROCKETS:

Cast steel, heat treated; one per side frame. Track drive sprocket assembly bolt-coupled to 3-stage planetary reduction gear unit outer case as an integral part of shoe-in type traction motor. Sealed between parts of rotation and non-rotation of the motor with floating seal.

IDLER WHEELS:

Cast steel, heat treated; one per side frame. Mounted on two bronze bushings with floating seals for lifetime lubrication.

TRACK ROLLERS:

Ten per side frame; each cast steel, double flanged, heat treated. All rollers mounted on two bronze bushings with floating seals for lifetime lubrication.

CARRIER ROLLERS:

Two per side frame; each cast steel, double flanged and heat treated. All rollers mounted on two bronze bushings with floating seals for lifetime lubrication.

TRACKS:

Heat treated, self-cleaning, multiple hinged track shoes joined by full floating pins; 53 pcs. per side frame.

Shoe width — 810mm wide.

Track adjustment — Manual adjustment device with oil jack and shim plate packs is standardized. As an optional extra, that idler wheels automatically adjusted while operation by means of hyd. cylinders actuated by power hydraulic supplied from operational hyd. pumps of superstructure is available instead.

TRAVEL AND STEERING:

A bi-directional, shoe-in type axial piston hydraulic motor bolt-couples drive sprocket thru 3-stage planetary reduction gear unit outer case at each crawler side frame end for travel and steer. Straight-line travel (forward or reverse), pivot or differential turns, and counter-rotation for spin turns available.

Brake — Spring-applied, hydraulically released multiple wet-disc type automatic brake; located within hydraulic motor. Brakes automatically set when travel levers are in neutral or when engine is shut down.

Travel speed — 1.8km/hr.

Gradeability — 30% (17°) permissible based on basic machine without front-end attachment.

Safety Devices

BOOM OVER-HOIST LIMITING DEVICE:

Limit switch type; provided at a part of boom foot to stop boom hoist motion with functions of automatic braking of boom hoist drum winch motor, and of hydraulic locking of counter-balance valve when boom angle reaches 80 degrees.

BOOM BACKSTOPS:

Dual; telescopic design with spring buffers.

DUAL BOOM OVER-HOIST LIMITING DEVICE:

Additional limit switch located on boom backstops; this is as a further safety device for redundant boom protection.

SWING LOCK:

Mechanically operated drop pin; available to firmly lock superstructure in four positions of facing front or rear or left or right to undercarriage.

DRUM LOCKS:

Electrically operated pawl locks is available on front and rear main drums while power hydraulically operated pawl lock is available on boom hoist drum with an automatic locking device as std.

THIRD DRUM LOCK:

Provided as std. when an optional 3rd drum winch is provided.

BOOM ANGLE INDICATOR:

Pendulum type; mounted on right-hand side of bottom section of crane main boom.

HOOK LATCH:

Provided on every kinds of hook to prevent out of place of cable from hook.

LEVEL GAUGE:

Bubble type; located on operator's cab floor of superstructure.

LEVER LOCKS:

Provided on all control levers (except swing lever) to lock levers in neutral.

SWING ALARM:

This is by buzzer, and flasher lamps located

on both sides of machinery cab.

SWING BRAKE LAMP:

Provided on operator's cab instrument panel; this is available to confirm whether or not swing brake is applied.

SIGNAL HORN:

Available as warning just before every kinds of motions from operator.

FOOL PROOF SHUT-OFF SYSTEM:

Located in the cab exit; this is available to automatically deactives and locks hydraulic system.

TRAVEL ALARM:

Buzzer warns when travel motion is initiated.

ENGINE MONITORING LAMPS:

Available for checking engine operating conditions like battery charge, engine oil pressure, radiator coolant level, oil filter clogging, air filter clogging, and battery electrolyte amount.

EMERGENCY MACHINE STOP BUTTONS:

Two; each located nearby front main and boom hoist drums. Available when it is necessary to stop all machine motion.

REAR VIEW MIRRORS:

Two each provided on front-left and -right corners of super-structure.

MICROPHONE & LOUD-SPEAKER:

Optional extra; this is for operator's convenience for loud speaking.

DRUM LIGHT & MIRROR:

Optional extra; these are available for checking rope winding onto front and/or rear drum(s).

Following items are available as std. and/or as optional extra when liftcrane application is required.

SML-10 LOAD MOMENT LIMITER:

Std. ; this is a fully computerized total safe operation control system, and automatic overload preventing system as standard equipment.

Construction (standard version) — Comprises (1) load detecting device with amplifier (2) angle detector for boom (3) computerized Micro Processing Unit (M.P.U.), and (4) display panel.

Functions — This system functions that if a lifting load reaches a 90% of the rated one specified in the crane capacity chart, an annunciating pre-warning (about to stop automatically) is given; if it is an 100%, a warning is given by red lamp, and annunciating warning (boom being overloaded), and all peril side motions are automatically stopped. The machine, however, can be operated in safety side motions.

Display panel indications — Followings are indication details on LCD 1 thru LCD 5:

a. After operation modes were set by means of mode setting keys on panel, LCD 1 indicates:

- (1) boom length;
- (2) kind of hook block (for boom of item 1);
- (3) no. of part-line (for hook block of item 2);
- (4) boom upper limit setting angle;
- (5) boom lower limit setting angle;
- (6) lifting curve number ("01" to "03");
- (7) "attached or non" of aux. short jib, and
- (8) lifting load ratio indication with 3 kinds of color lamping (green, yellow and red).

b. LCD 2 indicates:

- (1) engine rpm, or
- (2) lifting height (opt).

c. LCD 3 indicates:

- (1) present lifting load, or
- (2) rated load, or
- (3) remaining load.

d. LCD 4 indicates:

- (1) boom angle.

e. LCD 5 indicates:

- (1) present working radius, or
- (2) remaining working radius.

Display panel also provided with a thirteen-kind of indication lamp, and a function to indicate letter message on LCD 1 when machine becomes abnormal.

NON FREE-FALL OPERATION SWITCH:

Std; this is for keeping non free-fall operation during operation when it is necessary. Provided with key for switch on-off control.

HOOK OVER-HOIST LIMITING DEVICE:

Std. ; interlocked with the SML-10 for automatically preventing a hook over-hoist of crane main boom with functions of automatic drum braking, and warnings by red lamp and annunciating alarm.

BOOM OVER-HOIST AND -LOWERING LIMITING DEVICE:

Std. ; this is one of key safety devices; interlocked with the SML-10 also for automatically preventing boom over-hoist and -lowering with functions of automatic drum braking, and warnings by red lamp and annunciating alarm. Further boom protection from rapid boom over-hoist by hook over-hoist motion under mal-function of hook over-hoist limiting device is available as one of functions of the SML-10.

ANNUNCIATING ALARMS:

Std.; this is one of functions of the SML-10; provided with thirteen kinds of the alarm like "about to stop automatically".

SPEED SLOWDOWN DEVICE:

Std.; this is for speed slowdown of hoisting and lowering motions of boom which are available just before automatic stopping to prevent a shock.

ANNUNCIATING SWING ALARM:

Optional extra; this is additional alarm for swing motion with a caution voice of "now swing, keep clear please!".

ANNUNCIATING TRAVEL ALARM:

Optional extra; this is additional alarm for travel motion with a caution voice of "now

travel, keep clear please!".

AUX. CRANE HOOK OVER-HOIST LIMITING DEVICE:

Optional extra; this is available for auxiliary crane hoist with optional aux. short jib and/or fly jib. Performs the same function as that of "Hook over-hoist limiting device" mentioned before.

THREE COLOR PERCENTAGE INDICATOR:

Optional extra; this is with three colours of Green, Yellow and Red. Each colour indicates the load percentage to rated capacity; Green shows less than 90% as safety, Yellow shows 90 to 99% as marginal, and Red shows over 100% as over-loading. As further function, Red lamp comes on automatically when operator cuts off safety device switch absent-mindedly.

LIFTING HEIGHT METER:

Optional extra; available to indicate lifting height above ground or depth below ground on display "LCD 2" of SML-10 Load Moment Limiter display panel.

Front-end Attachment

BOOM:

Lattice construction, round tubular main chords, alloy, hi-ten steel, with bracing of round steel tubing.
 Boom connections.....In-line pin connections at 1.55m deep and 1.55m wide.
 Basic boomTwo-piece, 12.20m basic length; 6.10m bottom section, and 6.10m tapered top section.
 Boom head machineryAvailable in two kinds of head machineries; one is single of heavy duty sheave with roller type rope guard as std. for dragline application, and the other is a four-sheave machinery with rigid type rope guard as std. for liftcrane/clamshell applications. Sheaves all mounted on anti-friction bearings.
 Boom extensions.....Optional extra; available in 3.05m, 6.10m and 9.15m lengths with pendants.
 Maximum boom length.....24.40m for dragline/clamshell applications.
 60.95m for liftcrane applications.

AUXILIARY SHORT JIB:

Optional extra; available for liftcrane version. All-welded construction having single sheave head machinery. Pinned to 6.10m tapered top section. Available for 13.5ton lift as maximum with single part hoist line.

HOOK BLOCKS:

Optional extra; available for liftcrane application.
 90t, four sheavesOptional extra.
 50t, two sheavesOptional extra.
 35t, one sheaveOptional extra.
 13.5t, ball hookOptional extra.

BAIL AND BRIDLE:

All-welded construction; provided with larger sheaves of a 21.4 D/d ratio on both bail and bridle for 10-part boom hoist rope reeving. Bail pinned to A-frame gantry, and bridle suspended between a 10-part boom hoist rope and pendant ropes connecting to tip of 6.10m tapered top section.

DRUM DATA:

Drum	Root dia.	Type	Line speed (Hoisting, Lowering)	Cable	Max. line pull
Front (dragline bucket inhaul) (main crane hoist) (hammer grab crown holding via hook) (clamshell bucket holding) (MHL/MEH bucket hoist)	576mm	Spiral grooved or Parallel grooved	100 ~ 2mpm	28mm	245kN (25.0ton)
Rear (dragline bucket holding) (aux. crane hoist) (hammer grab holding & closing) (clamshell bucket closing) (MHL/MEH bucket hoist)	576mm	Spiral grooved or Parallel grooved	100 ~ 2mpm	28mm	245kN (25.0ton)
Boom hoist	526.4mm	Parallel grooved	51 ~ 2mpm	22.4mm	152kN (15.5ton)
Optional 3rd	448mm	Parallel grooved	59 ~ 2mpm	22.4mm	176kN (18.0ton)

Notes:

- 1. Line speed is based on drum first layer and rated engine rpm.
- 2. Hoisting line speed varies under load and operating conditions.
- 3. Two kinds of type of drum lagging are available; one is spiral grooved type as std. for dragline application, and the other is parallel grooved type as std. for other applications like liftcrane and clamshell.

Dragline 2.5m³ over

HOIST REEVING:

(ton)

Kind of hook block	No. of partline	8	7	6	5	4	3	2	1
90t		90.0	80.0	75.0	62.0	50.0	—	—	13.5
50t		—	—	—	—	50.0	—	—	13.5
35t		—	—	—	—	—	35.0	26.0	13.5
13.5t		—	—	—	—	—	—	—	13.5

CABLES:

- Front drumIWRC 6xP-WS (31), 28mm dia., breaking load 657kN (67.0t). Length depends on kind of application and boom length.
- Rear drumOptional extra; IWRC 6xP-WS (31), 28mm dia., breaking load 657kN (67.0t). Length depends on kind of application and boom length.
- Boom hoist drumIWRC 6xWS (31), 22.4mm dia./159m long, breaking load 367kN (37.4t).
- Optional 3rd drumOptional extra, IWRC 6xWS (26), 22.4mm dia., breaking load 367kN (37.4t). Length depends on kind of application and boom length.

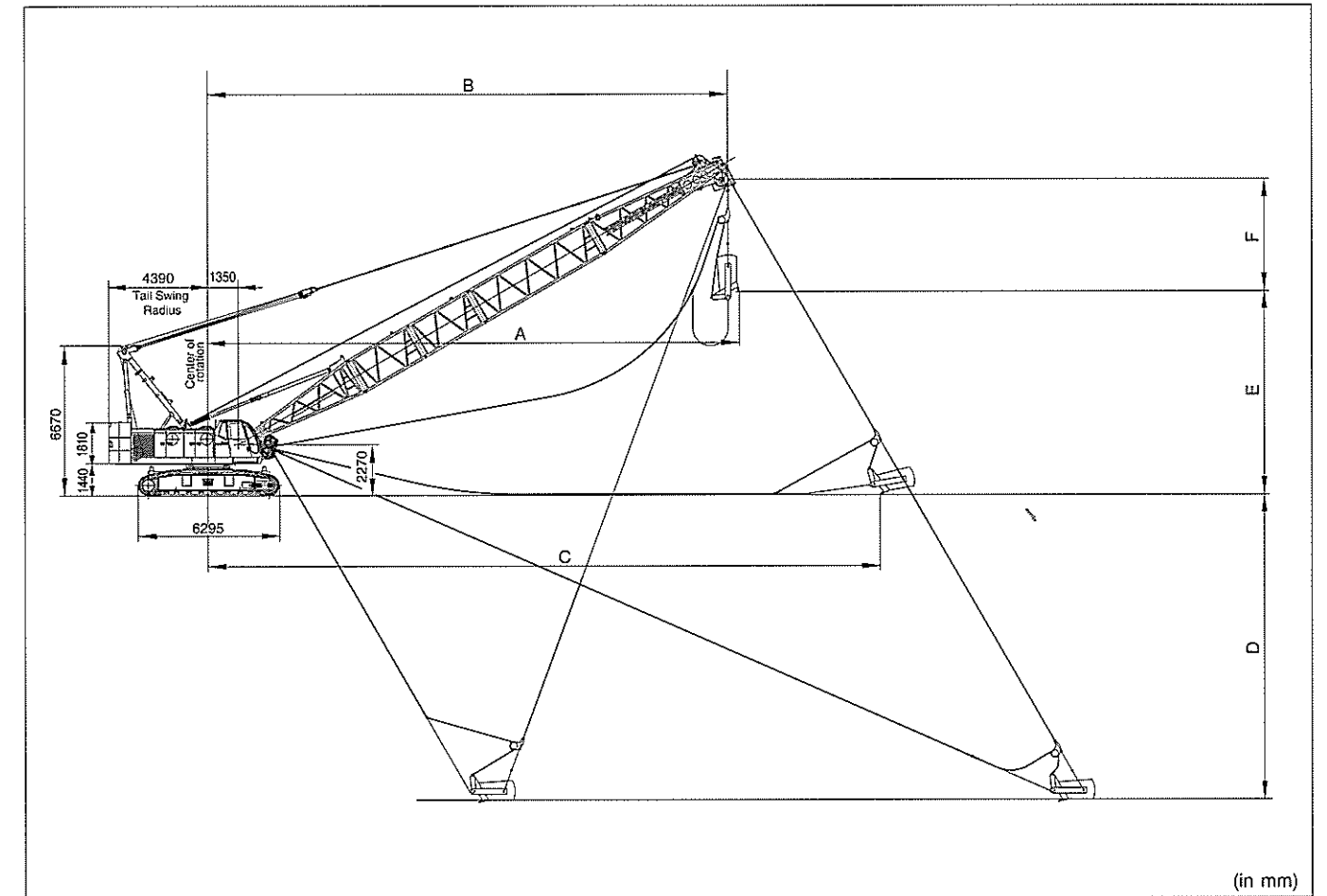

DRAGLINE RATINGS & WORKING RANGES:

	15.25			18.30			21.35			24.40		
	30	40	50	30	40	50	30	40	50	30	40	50
Rated load (t)	12.5	12.5	12.5	12.5	12.5	12.5	10.3	11.7	12.5	8.2	9.8	11.9
A Max. dumping radius (m)	15.8	14.4	12.6	18.4	16.8	14.5	21.0	19.1	16.5	23.7	21.4	18.4
B Working radius (m)	15.1	13.7	11.9	17.7	16.1	13.8	20.3	18.4	15.8	23.0	20.7	17.7
C Digging radius on G. L. (m)	19.3	18.9	18.0	22.6	22.2	20.9	25.9	25.4	24.0	29.3	28.5	26.9
D Digging depth (m)	10.3	10.0	9.3	12.7	12.4	11.5	15.2	14.8	13.8	17.8	17.2	16.0
E Dumping height (m)	3.6	5.8	7.7	5.1	7.7	10.1	6.6	9.7	12.4	8.1	11.7	14.7
F Bucket clearance (m)	5.8											

(EC402251)

Notes:

- Max. dragline rating is 12.5t.
- Mass of bucket plus material shall not exceed above rated loads.
- Boom length shall not exceed 24.40 m.
- High gantry is required and side frame must be extended for all operating conditions. Also, 28.8t counterweight, and 1.5t aux. weight (or 3rd drum winch) are required for all dragline ratings shown above.
- Dimension C and D vary considerably depending on digging conditions and skill of the operator.
- Apparent specific gravity of lifting material:
Earth1.7~1.8t/m³
Gravel1.8~2.0t/m³
- Dragline ratings shown above are in metric tons and are based on 78% of minimum tipping loads for the figures defined by stability.
- Max. digging radius of A, dumping height of E and bucket clearance of F are defined by a 2.5yd³ bucket.

WORKING MASS & GROUND PRESSURE:

Shoe width	Mass	Pressure
810mm	90.4t	94.7kPa <0.97kg/cm ² >

Note: Working mass shown above is with 24.40m boom, 28.8ton counterweight, 1.5ton auxiliary weight, fairlead and 2.5yd³ dragline bucket.

BUCKET DATA:

Bucket capacity (yd ³ /m ³)	Mass (t)
2.5/1.91	1.86
3.0/2.30	2.23
3.25/2.48	2.34
3.75/2.87	3.12

Note: All buckets shown above are as general digging application. Lightweight and heavy duty buckets are also available other than the above.

Clamshell 2.5m³ over

Liftcrane 90 metric tons

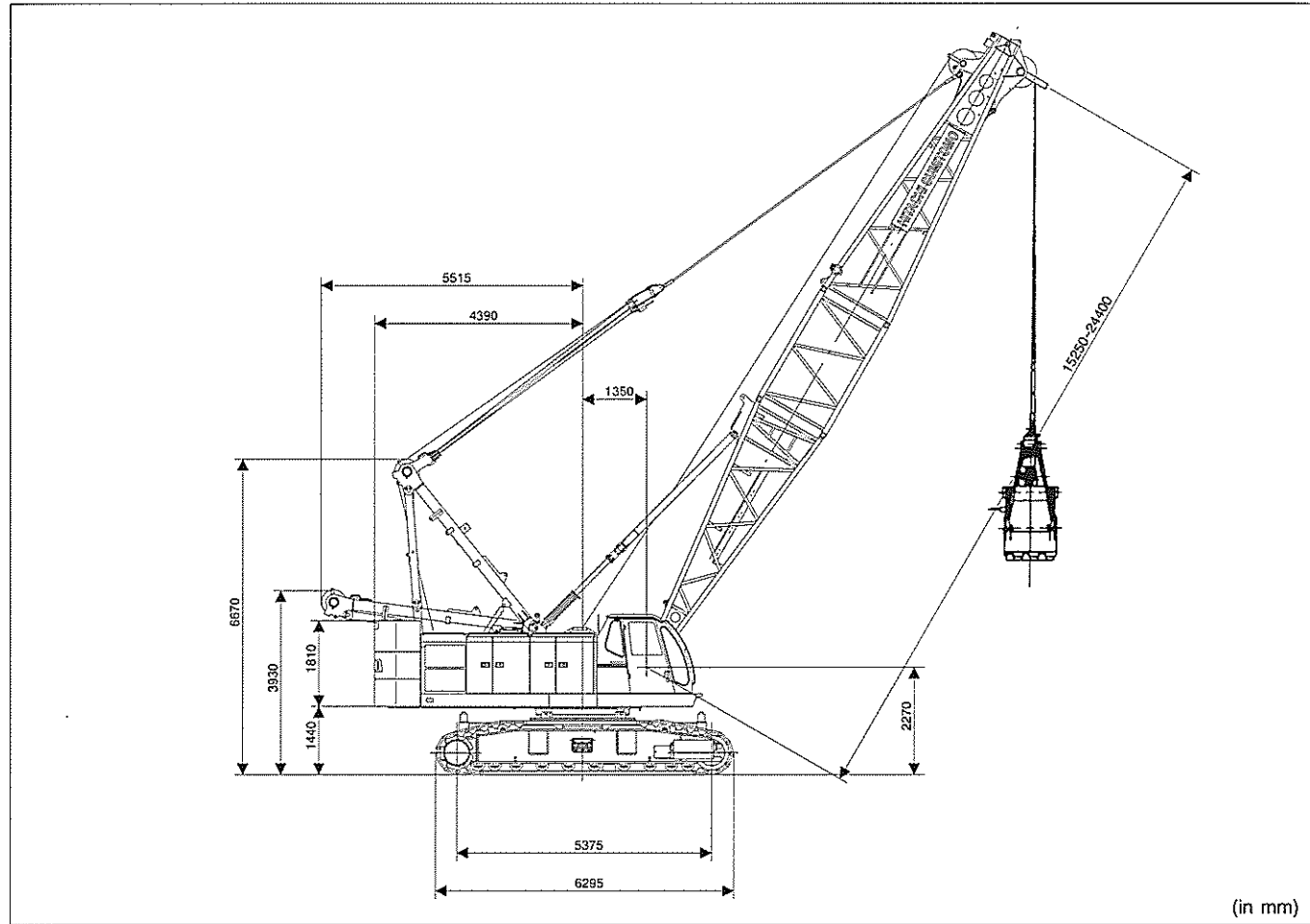

CLAMSHELL RATINGS:

(in metric tons)

Boom length (m) Working radius (m)	15.25	18.30	21.35	24.40
8.0	12.5			
9.0	12.5	12.5		
10.0	12.5	12.5	12.5	12.5/11.5
12.0	12.5	12.5	12.5	12.5
14.0	12.5	12.5	12.5	12.5
16.0		12.5	12.5	12.5
18.0			10.8	10.7
20.0				9.2

(EC402147)

Notes:

- Max. clamshell rating is 12.5ton.
- Following mass of bucket plus load should not exceed clamshell ratings shown above.

Bucket capacity	2.0m³	2.5m³	3.0m³
Bucket mass	4.5t	6.5t	6.5t

- Boom length shall not exceed 24.40m.
- Apparent specific gravity of lifting material:
Earth1.7~1.8t/m³
Gravel1.8~2.0t/m³
- High gantry is required and side frame must be extended for all operating conditions. Also, 28.8t counterweight, 1.5t aux. weight (or 3rd drum winch) are required for all clamshell ratings shown above.
- Clamshell ratings shown above are in metric tons and are based on 78% of minimum tipping loads for the figures defined by stability.

WORKING MASS & GROUND PRESSURE:

Shoe width	Mass	Pressure
810mm	92.3t	96.7kPa <0.99kg/cm²>

Note: Working mass shown above is with 24.40m boom, 28.8ton counterweight, 1.5ton auxiliary weight, hydraulic tagline winder and 2.0m³ clamshell bucket.

BUCKET DIMENSIONS:

(in m)

	2.0m³	2.5m³	3.0m³
A Bucket overall height (opened)	4.52	4.37	5.37
B Bucket overall height (closed)	3.69	3.46	4.36
C Bucket opening width	3.24	3.65	3.65

Notes:

- Buckets of 2.0/2.5m³ are for general excavating purpose.
- A 3.0m³ bucket is for light-duty service.

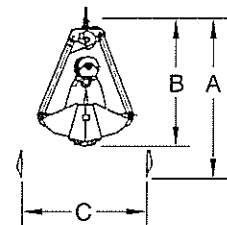

LIFTCRANE CAPACITIES:

Boom length (m) Working radius (m)	12.20	15.25	18.30	21.35	24.40	27.45	30.50	33.50	36.55	39.60	42.65	45.70	48.75	51.80	54.85	57.90	60.95
4.0	90.0																
4.5	80.5	77.0/4.6															
5.0	70.8	69.2	65.0/5.1	58.7/5.6													
6.0	55.0	55.0	55.0	54.9	52.9/6.2	47.0/6.7											
7.0	44.0	44.0	44.0	44.0	43.8	43.7	42.0/7.2	37.9/7.7									
8.0	36.4	36.4	36.3	36.2	36.1	36.1	36.0	35.8	35.0/8.3	31.0/8.8							
9.0	30.9	30.8	30.7	30.6	30.5	30.4	30.3	30.1	30.0	29.5	28.5/9.3	25.9/9.9					
10.0	26.7	26.6	26.5	26.4	26.3	26.2	26.1	25.9	25.8	25.7	25.7	25.5	25.0/10.4	22.6/10.9	20.5/11.5		
12.0	20.7	20.8	20.6	20.5	20.4	20.4	20.2	20.0	19.9	19.8	19.7	19.6	19.6	19.4	19.3	19.1	15.0/12.5
14.0	20.4/12.1	16.9	16.8	16.7	16.5	16.5	16.3	16.1	16.0	15.9	15.8	15.7	15.6	15.5	15.3	15.2	14.5
16.0		15.7/14.8	14.2	14.0	13.9	13.7	13.5	13.4	13.3	13.1	13.0	12.9	12.8	12.6	12.5	12.4	12.2
18.0			12.6/17.4	12.0	11.9	11.7	11.5	11.4	11.3	11.1	11.0	10.9	10.8	10.7	10.6	10.5	10.1
20.0				10.6	10.3	10.2	10.0	9.8	9.7	9.6	9.4	9.3	9.2	9.1	9.0	8.8	8.6
22.0					9.0	8.9	8.7	8.6	8.5	8.3	8.2	8.0	7.9	7.8	7.6	7.5	7.3
24.0					8.5/22.7	7.9	7.7	7.6	7.5	7.3	7.1	7.0	6.9	6.8	6.6	6.4	6.3
26.0						7.2/25.3	6.9	6.7	6.6	6.4	6.3	6.1	6.0	5.9	5.8	5.6	5.4
28.0							6.2	6.0	5.9	5.7	5.6	5.4	5.3	5.2	5.0	4.8	4.6
30.0								5.4	5.3	5.1	4.9	4.8	4.7	4.5	4.3	4.1	3.9
32.0								5.2/30.6	4.8	4.6	4.4	4.2	4.1	3.9	3.7	3.5	3.2
34.0									4.5/33.2	4.1	3.9	3.7	3.6	3.4	3.2	2.9	2.7
36.0										3.7/35.9	3.5	3.3	3.1	2.9	2.7	2.5	2.3
38.0											3.1	2.9	2.7	2.5	2.3	2.1	1.8
40.0											3.0/38.5	2.6	2.3	2.1	1.9	1.7	1.5
42.0												2.3/40.9	2.0	1.8	1.6		
44.0													1.8/43.5	1.5			

(EC401040)

WORKING MASS & GROUND PRESSURE:

Shoe width	Mass	Pressure
810mm	86.9t	91.0kPa <0.93kg/cm²>

Note: Working mass shown above is with 12.20m basic boom, 28.8ton counterweight, 1.5ton auxiliary weight, and optional 90t hook block.

Liftcrane Working Ranges

Notes — Liftcrane capacities

1. Capacities included in this chart are the maximum allowable, and are based on machine standing level on firm supporting surface under ideal job conditions.
2. Capacities are in metric tons, and are not more than 78% of minimum tipping loads except the figures surrounded by bold lines which are based on other factor of machine structural strength limitation.
3. Capacities are based on freely suspended loads and make no allowance for such factors as the effect of wind, sudden stopping of loads, supporting surface conditions, and operating speeds. Operator must reduce load ratings to take such conditions into account. Deduction from rated capacities must be made for mass of hook block, weighted ball/hook, sling, spreader bar, or other suspended gear.
Hook block mass is as follows:
90t.....1.20ton 50t.....0.81ton 35t.....0.64ton
13.5t.....0.60ton
4. All capacities are rated for 360° swing.
5. Least stable rated condition is over the side.
6. A 28.8ton counterweight and 1.5ton auxiliary weight (or opt. 3rd drum winch) are required for all capacities on this chart.
7. Crawler side frame must be fully extended for all operating conditions.
8. Attachment must be erected and lowered over the ends of the crawler mounting.
9. Main boom length must not exceed 60.95m.
Maximum boom length when mounting auxiliary short jib is 54.85m.
10. Capacities when handling load off main boom head sheaves in case of mounting auxiliary short jib on top of boom are detailed; if required, please consult us or nearest distributor.

SCX900HD-1 AUXILIARY SHORT JIB CAPACITIES:

Max. 13.5ton

Note: Jib capacities is almost equal to the figures made by the deduction of a 300kg from the liftcrane capacities for boom length up to 54.85m unless restricted by the maximum jib capacity shown above. As to the details, please consult us or nearest distributor.

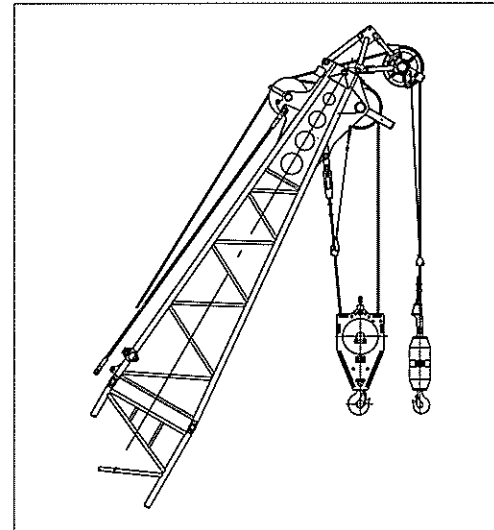

Auxiliary short jib (Option)

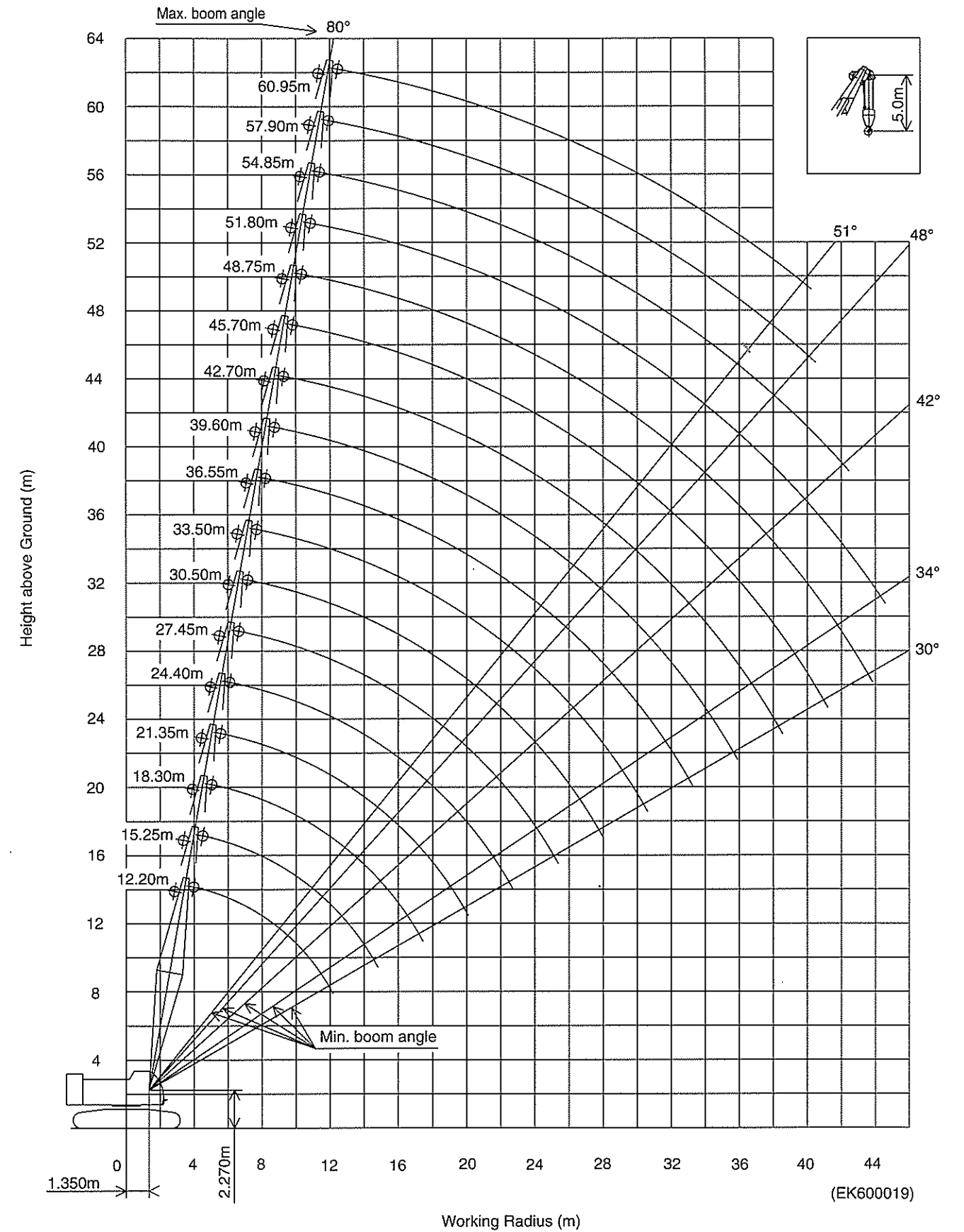

Standard and Optional Equipment

	Standard equipment	Optional equipment
Superstructure	<ul style="list-style-type: none"> ● Mitsubishi 6D24-TL diesel engine with a 235kW <320ps> rated output; ● Hydraulic system with three variable displacement axial piston pumps and one fixed displacement duplicate tandem gear pump; provided with an independent oil cooler; ● Control system with one each of duplicate and triplicate tandem valves and pilot-operated arm chair single axis control levers; ● Motorcycle type "SC" controller (easy-precise-minute engine rpm and hyd. pump oil flow control device); ● Front and rear main operating drum winches of 25ton line pull with 576mm dia. drum lagging driven by independent variable displacement hyd. motor with independent hyd. circuit; provided with linkless, hydrostatically-operated external contracting band brake of 1,270mm dia. by 170mm wide capable of two functions of automatic and free-fall mode, with hyd. booster, and a forced air-cooling system; ● Boom hoist mechanism driven by hyd. motor with automatic brake; ● Swing mechanism with turntable bearing; driven by two hyd. motor w/spring-applied, hydraulically released multiple wet-disc brake; provided with speed control device; ● Power hydraulically retractable A-frame gantry; ● All new stamped, automotive type, full-vision operator's cab with large curved front window; provided with an arrangement of armchair operator control station and instrument panel; ● 28.8ton counterweight; ● 1.5ton auxiliary weight; if optional 3rd drum is required, this aux. weight is deleted; ● Machinery cab with hinged doors; ● 24-volt electrical system with two 12-volt batteries; ● Lighting system: <ul style="list-style-type: none"> • Two 70W working lights; • One 10W interior cab light; ● Accessories: <ul style="list-style-type: none"> • AM/FM radio w/clock; • Engine hourmeter; • Engine tachometer; • Fuel gauge; • Thermometer; • Hyd. oil temp. gauge; • Pilot line pressure gauge; • Foot throttle; • Dual, intermittent window shield wipers with washers; • Cigar lighter; • Ash tray; • Book holder; • Sunvisor; • Sunshade; • Cup Holder; • Non-skid surfaces; • Cab front step; • Cab floor mat; • Superstructure under-cover. ● Std. spare parts and tools. 	<ul style="list-style-type: none"> ● Third drum winch; ● Third drum cable; ● Hyd. tagline winder (as std. clamshell application); ● Fairlead (as std. for dragline application); ● Drum rollers; available on front/rear main; ● Stone guard; this is for operator's cab; ● Fire extinguisher; ● Catwalks along both sides of machinery cab; ● Built-in type full air-conditioning; ● Re-fuel pump; ● Heater; ● Operator's cab sidestep; ● Electric cab fan.

	Standard equipment	Optional equipment
Undercarriage	<ul style="list-style-type: none"> ● 4,180mm gauge by 6,295mm long crawler lower with power hydraulically retractable/extendible crawler side frames; ● Crawler drive units with shoe-in type traction motor with wet-disc type automatic brakes; ● 810mm wide track shoes; ● Manual track tension adjusting devices; ● Lifetime lubricated track components; ● Crawler side steps. 	<ul style="list-style-type: none"> ● Automatic track tension adjusting device, i/o manual one as std.
Front-end Att.	<ul style="list-style-type: none"> ● 12.20m basic boom; 6.10m bottom section, and 6.10m tapered top section; ● Four boom head sheaves w/rigid type cable guard (as std. for liftcrane & clamshell application); ● Single of heavy duty dragline sheave w/roller type cable guard (as std. for dragline application); ● Bail and bridle assemblies; ● Front drum cable of 28mm dia.; ● Boom hoist cable; 22.4mm dia./159m long. <p>Note: In case of dragline and clamshell applications, a 15.25m boom of 12.20m basic plus one opt. 3.05m boom extension is recommended as minimum length of boom.</p>	<ul style="list-style-type: none"> ● 3.05m boom extension; ● 6.10m boom extension; ● 9.15m boom extension; ● Auxiliary short jib; ● 90t hook block; ● 50t hook block; ● 35t hook block; ● 13.5t ball hook; ● Rear drum cable of 28mm dia.. ● Boom skywalk; available for all sections of boom attachment.

