

Superstructure

UPPER REVOLVING FRAME: All-welded, precision machined unit; mounts jig-line bored side housings for true alignment of the horizontal shaft assemblies.

TURNTABLE BEARING WITH INTEGRAL SWING GEAR: Outer bearing race with integral, external swing (ring) gear bolted to carrier deck; inner bearing race bolted to upper revolving frame.

CONTROL SYSTEM: "Speed-O-Matic" power hydraulic system that includes a gear pump to provide a constant flow of oil, an accumulator to maintain operating pressure and variable pressure control valves to regulate this pressure to all the clutches, and to release swing and boomhoist brakes.

CLUTCHES: "Speed-O-Matic" power hydraulic actuated, internal expanding, 2-shoe type for all function.

DRUMS: Front and rear main, and optional third, operating drums.

Drum laggings --- 2-piece, removable; bolted to brake drum which is involute-splined to drum shaft mounted in line bores on ball bearing.

Brake --- External contracting band; mechanically foot pedal operated, with locking latch.

Automatic brake --- Optional extra; applied when control lever is at neutral position, and available on both front and rear main drums in addition to free-fall brake mode as std.

INDEPENDENT BOOMHOIST: Spur gear driven with precision boom raising and lowering through the clutches.

Drum --- Involute-splined to shaft; provided with brake drum and drum locking ratchet wheel cast integral.

Brake --- External contracting band, spring applied and power hydraulically released; applied automatically whenever control lever is at neutral position.

Lock --- Mechanically controlled drum locking pawl.

SWING: Spur gear driven; 2 sets of clutches transmit swing power smoothly into the swing pinion. Swing pinion meshes with external teeth of swing gear integral with outer race of turntable bearing.

Brake --- Two-directional, external contracting band, spring applied, power hydraulically released; applied manually thru swing brake lever. Brake drum is involute-splined to swing shaft directly.

Lock --- Mechanically controlled drop pin.

Speed --- 3-speed; 4.4min⁻¹(high)/2.9min⁻¹(mid.)/1.5min⁻¹(low).

GANTRY: Retractable high gantry with power hydraulic cylinder.

OPERATOR'S CAB: Full-vision, full compartment with safety glass panels, separated from upper machinery with an inside door.

COUNTERWEIGHT: Removable; mounted on rear of upper revolving frame. Counterweight raised or lowered by retractable high gantry with power hydraulic cylinder.

POWER UNIT:

Make & model	Mitsubishi 6D14T
Type	Water-cooled, 4-cycle, turbo-charged diesel engine
No. of cylinder	Six (6)
Bore & stroke	110 x 115 mm
Displacement	6,557 cc
Rated output	95.6kW/2,000min ⁻¹ <130PS/2,000r.p.m.>
Maximum torque	500N·m/1,400min ⁻¹ <51kg-m/1,400r.p.m.>
Fuel tank	250 liters
3-speed transmission	Power-shift type

Crane Carrier

MODEL: Nissan KL-KG532VN, 8 x 4 drive.

FRAME: All-welded construction ladder type.

ENGINE: Model Nissan RG8, water-cooled, 4-cycle, 8-cylinder, displacement 17,990cc, diesel engine, max. output 235kW/2,200min⁻¹ <320ps/2,200rpm>, max. torque 1,098N·m/1,200min⁻¹ <112kg-m/1,200rpm>, fuel tank 300 liters; provided with an electronic governor control.

CLUTCH: Dry single plate, hydraulically operated clutch release mechanism with air booster.

TRANSMISSION: Seven forward speeds and one reverse speed, synchromesh on 2nd thru 7th and constantmesh on 1st and reverse gears.

FINAL DRIVE GEAR: A 4.875 reduction ratio Hypoid gears under in-line tandem arrangement at center together with a 1.523 reduction ratio planetary and sun gears at hub; provided with 3rd differential lock.

TRAVELING SPEED: Max. 65km/h in traveling condition (under a 40.4t GVW with 12.20m basic boom and 50t hook block w/out 11t c.t.w.t.).

GRADEABILITY: 0.43(tan θ) (under a 40.4t GVW).

TURNING RADIUS: 11.6 meters.

FRONT AXLES: Welded tubular-section steel beam; provided with reverse-Elliot steering knuckles.

Suspension --- Under-hanging high tensile steel equalizer beam with rubber bushing at ends; includes four torque rods (no spring).

REAR AXLES: Full-floating, cast steel housing, in-line tandem type.

Suspension --- Under-hanging high tensile steel equalizer beams with tow torque rods (no spring).

WHEELS & TIRES: Single tire on front wheels, dual tire on rear wheels.

Front tire --- 13.00-20-20PR.

Rear tire --- 13.00-20-20PR.

BRAKES:

Service --- Full air brake on all wheels, dual air line system, internal expanding leading and trailing shoe type; provided with automatic struck adjuster.

Parking --- Pneumatically-controlled spring brake; applied on four rear wheels. Provided with gradual control device.

Auxiliary --- Exhaust brake and engine compression release brake.

STEERING: Recirculating ball screw type, with linkage type power steering.

OUTRIGGERS: Four-hydraulically operated beam and jack cylinder; simultaneously or individually controlled from either side of carrier with control device arrangement including superstructure engine acceleration device; provided with level gauges.

Extended width --- 6,200mm.

Distance between outriggers --- 5,510mm.

FRONT JACK: Optional extra; available to ensure lifting performance at 360° around the crane. Provided with pressure switch, warning lamp and alarm.

DRIVER'S CAB: All steel, semi under-floor type, right-handed one side cab with two seats.

ELECTRIC SYSTEM: 24-volt, negative earth; provided with an alternator of 24V-50A and two of 12V-120AH batteries.

WEIGHT: Approx. 24,040kg (with outriggers).

We are constantly improving our products and therefore reserve the right to change designs and specifications without notice.

Hitachi Sumitomo Heavy Industries Construction Crane Co., Ltd.

12-14, Ueno 7-chome, Taito-ku, Tokyo 110-0005, Japan

Phone: 81-3-3845-1387 Facsimile: 81-3-3845-1394

HITACHI SUMITOMO ST 500M

Crane 50 metric tons

ST 500M CRANE CAPACITIES:

(in metric tons)

Working radius (m)	On outriggers														Working radius (m)
	Boom length (m)														
	12.20	15.25	18.30	21.35	24.40	27.45	30.50	33.55	36.60	39.65	42.70	45.75	48.80	51.85	
3.7	*50.0														3.7
4.0	*46.8	*43.0/4.4													4.0
5.0	*38.3	*38.2	*38.1	*34.0/5.6											5.0
6.0	*32.2	*32.1	*32.0	*31.9	*30.5/6.2	*27.5/6.8									6.0
7.0	*27.5	*27.4	*27.3	*27.2	*27.1	*27.0	*24.0/7.4								7.0
8.0	*23.9	*23.8	*23.7	*23.6	*23.5	*23.4	*23.3	*21.0	*19.0/8.6						8.0
9.0	*21.1	*21.0	*20.9	*20.8	*20.7	*20.6	*20.5	*20.4	*18.7	*16.5/9.2	*14.5/9.8				9.0
10.0	*18.8	*18.7	*18.6	*18.5	*18.4	*18.3	*18.2	*18.1	*17.8	*15.8	*14.4	*13.0/10.4	*10.5/11.0		10.0
12.0	16.2/11.6	15.5	15.4	15.3	15.2	15.1	15.0	14.9	14.8	*14.2	*13.1	*12.3	*10.3	*8.4	12.0
14.0		13.0	12.9	12.8	12.7	12.6	12.5	12.4	12.3	12.2	11.8	*11.3	*9.8	*8.0	14.0
16.0		12.8/14.3	11.1	11.0	10.9	10.8	10.7	10.6	10.5	10.4	10.3	10.2	*9.3	*7.6	16.0
18.0			10.4/17.0	9.6	9.5	9.4	9.3	9.2	9.1	9.0	8.9	8.8	8.7	*7.2	18.0
20.0				8.6/19.6	8.3	8.2	8.1	8.0	7.9	7.8	7.7	7.6	7.5	*6.8	20.0
22.0					7.3	7.2	7.1	7.0	6.9	6.8	6.7	6.6	6.5	6.4	22.0
24.0					7.2/22.2	6.3	6.2	6.1	6.0	5.9	5.8	5.7	5.6	5.5	24.0
26.0						6.0/24.9	5.5	5.4	5.3	5.2	5.1	5.0	4.9	4.8	26.0
28.0							5.0/27.5	4.8	4.7	4.6	4.5	4.4	4.3	4.2	28.0
30.0								4.3	4.2	4.1	4.0	3.9	3.8	3.7	30.0
32.0									3.7	3.6	3.5	3.4	3.3	3.2	32.0
34.0									3.5/32.7	3.2	3.1	3.0	2.9	2.8	34.0
36.0										3.0/35.4	2.8	2.7	2.6	2.5	36.0
38.0											2.5	2.4	2.3	2.2	38.0
40.0												2.2	2.1	2.0	40.0

Notes:

- Capacities shown are in metric tons and are based on 85% of minimum tipping loads - over the side - with machine standing level on firm supporting surface under ideal job conditions. Deductions from the crane capacities must be made for weight of hook block.
- When handling load off the main boom peak sheaves in case of mounting jib on top of boom, the following deductions from crane capacities shown above must be made:

Kind of hook block	50 t	15 t	5 t
Weight of hook block (t)	0.75	0.3	0.12

Jib length (m)	6.10	9.15	12.20	15.25
Weight to be deducted (t)	0.8	0.9	1.0	1.1

- Asterisk (*) indicates that capacities are based on factors other than those which would cause a tipping condition.
- An 11t counterweight is required for all capacities on this chart.
- Outriggers must be fully extended to 6.2 m for all operating conditions.

ST 500M JIB CAPACITIES:

(in metric tons)

Jib length (m)	Jib angle		
	0°	15°	30°
6.10	5.0	4.5	3.6
9.15	4.5	3.6	2.8
12.20	3.6	2.6	1.8
15.25	2.1	1.5	N.A.

Notes: Determining jib capacities.

- The jib capacities are equal to the crane capacities of the main boom on which the jib is fixed unless restricted by the maximum jib capacities shown above.
- The jib angle to boom must not exceed 30° when lifting.
- Available boom length to mount jib of all length is from 24.40 thru 51.85 m.

MAXIMUM BOOM/JIB LENGTHS MACHINE CAN LIFT OFF GROUND UNASSISTED (without load):

(in meters)

On outriggers				On tires			
Over rear		Over side		Over rear		Over side	
Boom	Boom+Jib	Boom	Boom+Jib	Boom	Boom+Jib	Boom	Boom+Jib
51.85	64.05	51.85	54.90	39.65	42.70	39.65	42.70

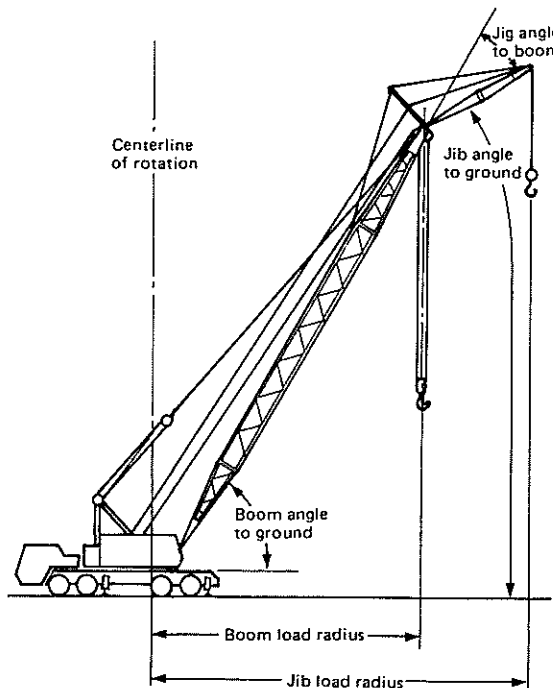

ST 500M CRANE WORKING RANGES:

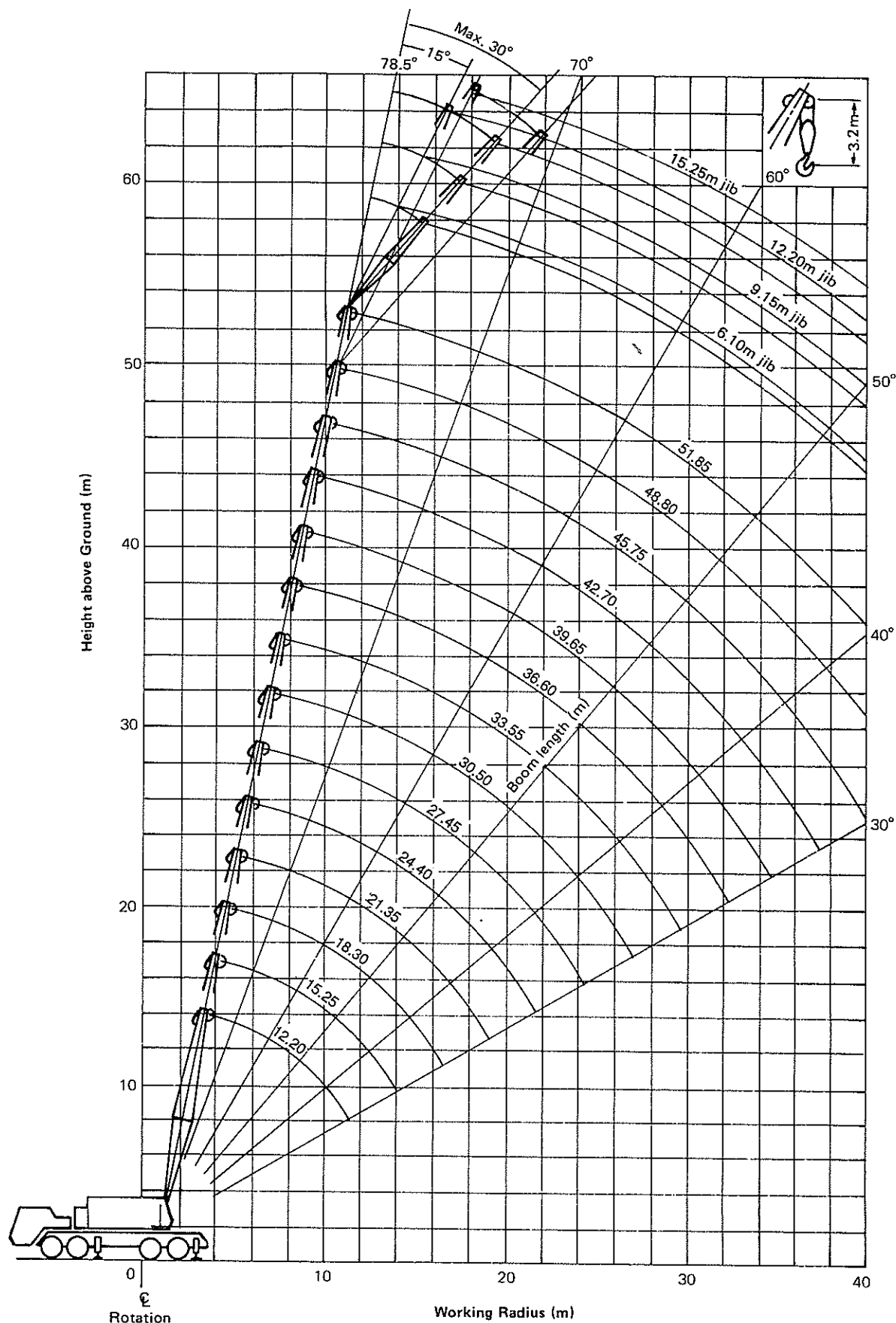

CRANE BOOMS: Lattice construction; round tubular main chords, alloy, hi-ten steel, with bracing of round steel tubing.

- Boom connections In-line pin connections.
- Basic boom Two-piece, 12.20 m basic length; 6.10 m long bottom and top sections; 1.20 m deep and 1.27 m wide at connections.
- Boom point machinery Five head sheaves mounted on antifriction bearings.
- Boom extensions (optional extra) Available in 3.05 m, 6.10 m and 9.15 m lengths with pendants.
- Maximum boom length 51.85 m.
- Basic fly jib (optional extra) Two-piece; 6.10 m basic length with 3.05 m long bottom and top sections.
- Fly jib extension (optional extra) Available in 3.05 m length.
- Maximum fly jib length 15.25 m.
- Boom plus fly jib length 51.85 m + 6.10 m.
51.85 + 9.15 m.
51.85 + 12.20 m (max.)
48.80 m + 15.25 m (max.)
- Aux. short jib (optional extra) Available for auxiliary crane hoist of 5ton or less; mounted on 6.10 m top section.

HOOK BLOCK:

- 50 t, four sheaves Standard.
- 15 t Optional extra.
- 5 t Standard for fly jib and/or auxiliary short jib.

BOOM HOIST ASSEMBLY: With power lowering clutch.

- 14-part boom hoist reeving Standard.
- Boom hoist line speed (hoisting) @52m/min(high)/34m/min(mid.)/17m/min(low)
- Boom hoist line speed (lowering) @42m/min(high)/28m/min(mid.)/14m/min(low)

LINE PULL AND LINE SPEED:

Drums	Root dia.	Type	Line pull	Line speed	Cable dia.
Front (main hoist)	380 mm	parallel grooved	83.3kN <8,500 kg> with 'high' line speed; 122.5kN <12,500 kg> with 'mid.' and 'low' line speeds;	hoisting: @ 65 m/min (high) @ 43 m/min (mid.) @ 21 m/min (low)	20 mm
Rear (aux. hoist)	380 mm	parallel grooved		lowering: @ 52 m/min (high) @ 34 m/min (mid.) @ 17 m/min (low)	20 mm

(Available line pull - Not based on wire rope strength)

HOIST REEVING:

No. of part line	Main hoist									Aux. hoist
	9	8	7	6	5	4	3	2	1	1
Max. load (t)	50.0	44.8	39.2	33.6	28.0	22.4	16.8	11.2	5.6	5.0

GANTRY: Retractable high gantry with power hydraulic cylinder.

WORKING WEIGHT: 51.4 t (with basic boom, counterweight "A" and 50 t hook block).

COUNTERWEIGHT: "A" (11,000 kg).

POWER LOAD LOWERING CLUTCH:

- On front drum Standard.
- On rear drum Optional extra.

SAFETY DEVICES: Hook over-hoist alarm, boom over-hoist limiting device, boom angle indicator, boom backstops, boom hoist drum pawl lock.

MODEL SML-06 LOAD MOMENT ALARM: Optional extra; this is a computerized automatic over-load warning device.

CABLES:

- For main hoist IWRC 6 x WS(26), 20 mm dia.; breaking load 304 kN <31 t>.
- For boom hoist IWRC 6 x WS(31), 16 mm dia.; breaking load 187.3 kN <19.1 t>.
- For aux. hoist (optional extra) IWRC 6 x WS(26), 20 mm dia.; breaking load 304 kN <31 t>.

We are constantly improving our products and therefore reserve the right to change designs and specifications without notice.

Hitachi Sumitomo Heavy Industries Construction Crane Co., Ltd.

12-14, Ueno 7-chome, Taito-ku, Tokyo 110-0005, Japan

DIMENSIONS:

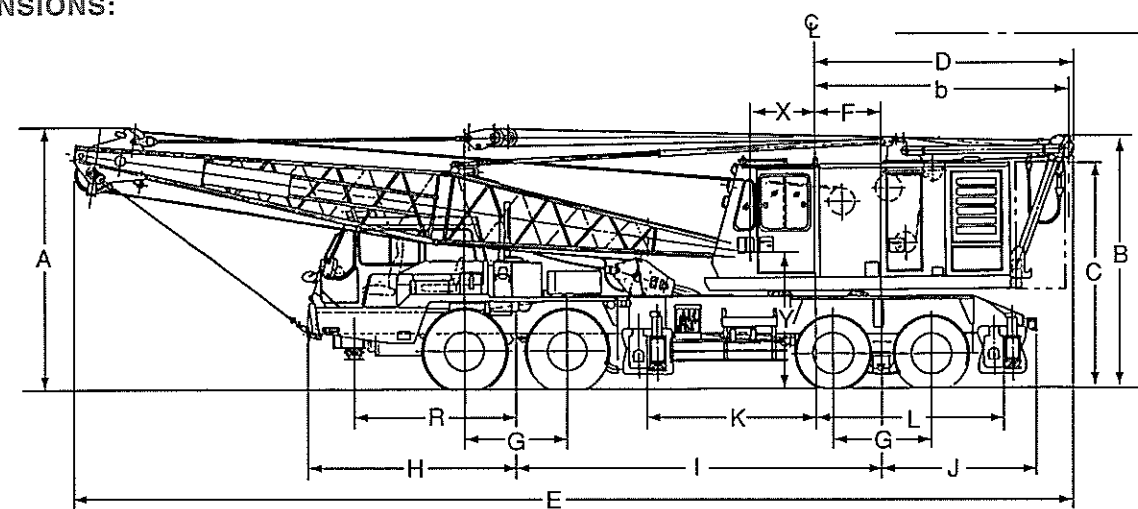

(Not to scale)

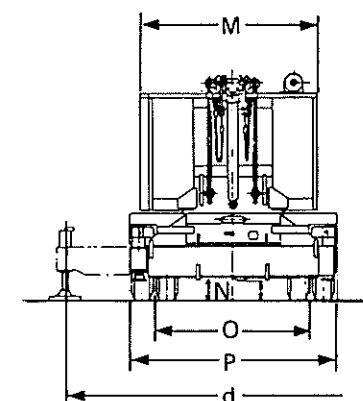

- Notes:**
- An 11t counterweight must be removed whenever travelling.
 - Travelling with an 11t counterweight is only allowed when it is "within-a-jobsite-driving", and its travelling speed must be less than 3 km/hr. as much as slow like crawling.

In traveling condition:

- A: Overall height 3.990 m
- B: Height of gantry (lowered) 3.630 m
- C: Height of cab 3.280 m
- D: Radius of rear end (gantry lowered) 4.155 m
- E: Overall length 17.600 m
- F: Center of rotation to center of rear bogie 1.150 m
- G: Distance between axles
front 1.470 m
rear 1.470 m
- H: Center of front bogie to front of carrier 2.975 m
- I: Wheelbase 5.530 m
- J: Center of rear bogie to rear of carrier 2.305 m
- K: Center of rotation to center of front outriggers 2.580 m
- L: Center of rotation to center of rear outriggers 2.930 m
- M: Width of cab 2.830 m
- N: Minimum ground clearance 0.250 m
- O: Tread
front 2.765 m
rear 2.480 m
- P: Overall width 2.240 m
- R: Center of front bogie to center of front jack 2.295 m
- X: Center of rotation to boom foot pin 0.940 m
- Y: Height from ground to boom foot pin 1.980 m

In working condition:

- a: Height of gantry (raised) 5.240 m
- b: Radius of rear end (counterweight) 3.950 m
- d: Width of outriggers extended 6.200 m

CLAMSHELL BOOMS: Lattice construction; round tubular main chords, alloy, hi-ten steel, with bracing of round steel tubing.

Boom connections --- In-line pin connections.

Basic boom --- Two-piece, 12.2m basic length, 6.1m bottom and top sections; 1.20m deep and 1.27m wide at connections.

Boom point machinery --- Five head sheaves mounted on anti-friction bearings.

Boom extensions --- Available in 3.05m and 6.10m lengths with pendants.

MAXIMUM CLAMSHELL RATING: 5.0 t.

BOOM HOIST ASSEMBLY: With power lowering clutch.

14-part boom hoist reeving Standard.

Boom hoist line speed (hoisting)
 @52m/min (high).
 @34m/min (mid.).
 @17m/min (low).

Boom hoist line speed (lowering)
 @42m/min (high).
 @28m/min (mid.).
 @14m/min (low).

GANTRY: Retractable high gantry with power hydraulic cylinder.
WORKING WEIGHT: 53.1 t with basic boom, counterweight "A" and 1.0m³ clamshell bucket.

COUNTERWEIGHT: "A" (11,000 kg).

SAFETY DEVICE: Boom over-hoist limiting device, boom angle indicator, boom backstops, boom hoist drum pawl lock.

TAGLINE WINDER: Spring-wound, drum-type mounted on boom; double stage type. Available for under-ground lift of 20m as max.

POWER LOAD LOWERING CLUTCH:

On front drum Standard.

On rear drum Optional extra.

LINE PULL AND LINE SPEED:

Drums	Root dia.	Type	Line pull	Line speed	Cable dia.
Front (holding)	380mm	Parallel Grooved	83.3kN <8,500 kg> with 'high' line speed;	Hoisting: @ 65 m/min (high) @ 43 m/min (mid.) @ 21 m/min (low)	20mm
Rear (closing)	380mm	Parallel Grooved	122.5kN <12,500 kg> with 'mid.' and 'low' line speeds;	Lowering: @ 52 m/min (high) @ 34 m/min (mid.) @ 17 m/min (low)	20mm

(Available Line Pull - Not based on wire rope strength)

ST 500M CLAMSHELL CAPACITIES AND WORKING RANGES:

(in metric tons)

Boom length (m)								
12.20			15.25			18.30		
R (m)	A (°)	L (t)	R (m)	A (°)	L (t)	R (m)	A (°)	L (t)
6.6	65	5.0						
8.0	57	5.0	7.9	65	5.0			
9.0	52	5.0	9.0	60	5.0	9.2	65	5.0
10.0	45	5.0	10.0	56	5.0	10.0	62	5.0
11.3	35	5.0	12.0	46	5.0	12.0	55	5.0
			13.8	35	5.0	14.0	46	5.0
						16.3	35	5.0

R: Working radius A: Boom angle L: Rated load

1. Weight of bucket (2.4 t) plus load should not exceed these capacities.

2. Boom length shall not exceed 18.30m.

3. Larger size bucket can be approved depending on type of material, type of bucket within limitation of rating chart.

4. Apparent specific gravity of lifting material:

Earth 1.7~1.8 t/m³

Gravel 1.8~2.0 t/m³

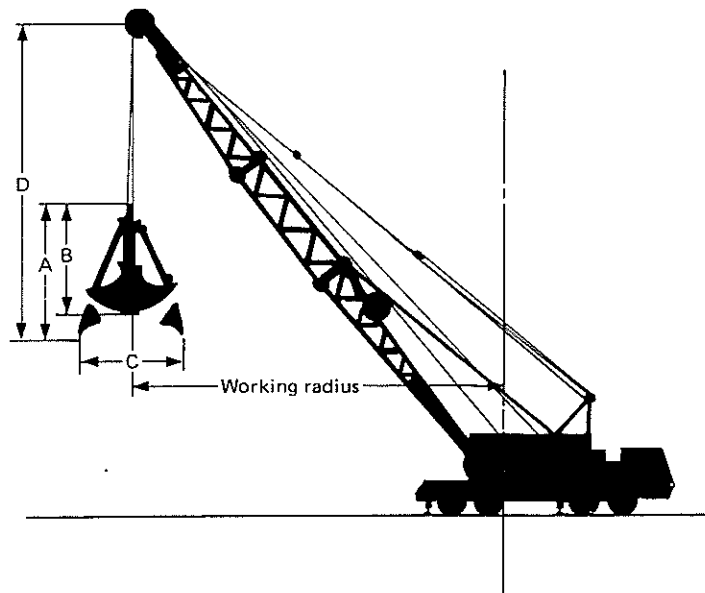

(in meters)

A	Bucket overall height (opened)	3.30
B	Bucket overall height (closed)	2.80
C	Bucket opening width	2.54
D	Bucket clearance	4.30

We are constantly improving our products and therefore reserve the right to change designs and specifications without notice.

Hitachi Sumitomo Heavy Industries Construction Crane Co., Ltd.

12-14, Ueno 7-chome, Taito-ku, Tokyo 110-0005, Japan

Phone: 81-3-3845-1387 Facsimile: 81-3-3845-1394