

**SCX1000A-3**

Stage V

# **SCX 1000A-3**

---

**HYDRAULIC CRAWLER CRANE**

**Hoist Rope 26mm  
12t-Rated Line Pull**



# Variation of The Attachment

Line Speed *	Front / Rear Winch (Rated with 12 t load)	m/min	110 (45)
	Third Winch (Rated with 12 t load)		95 (30)
Swing Speed		min <sup>-1</sup> (rpm)	2.4
Travel Speed High / Low *		km/h	2.0 / 1.1
Gradeability		% (Degree)	30 (17)
Engine Model			Cummins B6.7 (Stage V)
Engine Maximum Output		kW/min <sup>-1</sup> (ps/rpm)	209/2000 (284/2000)

Note : Speeds marked with "\*" may vary depending on load applied.

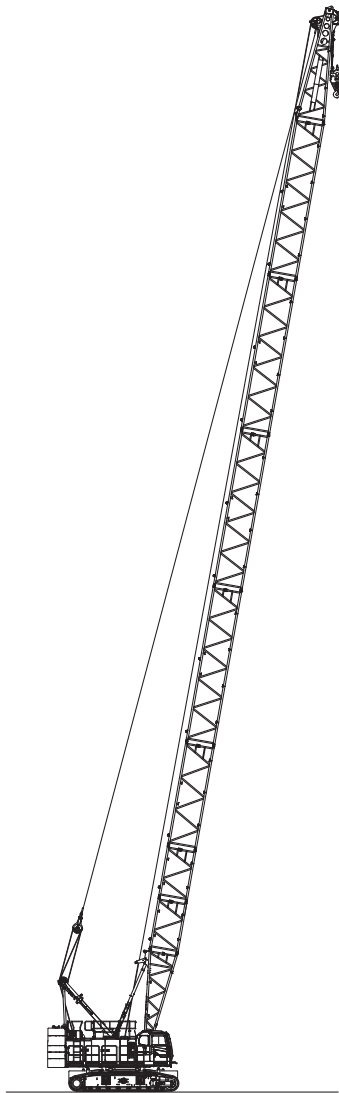

**Crane Specification  
(Boom Longest Length)**

Boom Length	m	12 to 60
Ground Contact Pressure	kPa (kgf/cm <sup>2</sup> )	124 (1.26) (Boom longest length with 35 t hook)
Overall Operating Weight	t	Approximately 110 (Boom longest length with 35 t hook)

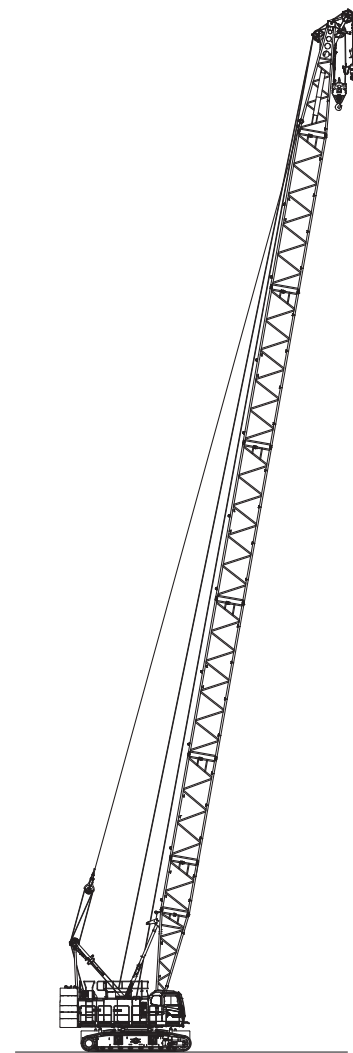

**Crane Specification  
(Boom Longest Length with Aux. Sheave)**

Boom Length	m	12 to 57
Ground Contact Pressure	kPa (kgf/cm <sup>2</sup> )	124 (1.27) (Boom longest length + 35 t aux. sheave + 12 t hook attached)
Overall Operating Weight	t	Approximately 111 (Boom longest length + 35 t aux. sheave + 12 t hook attached)

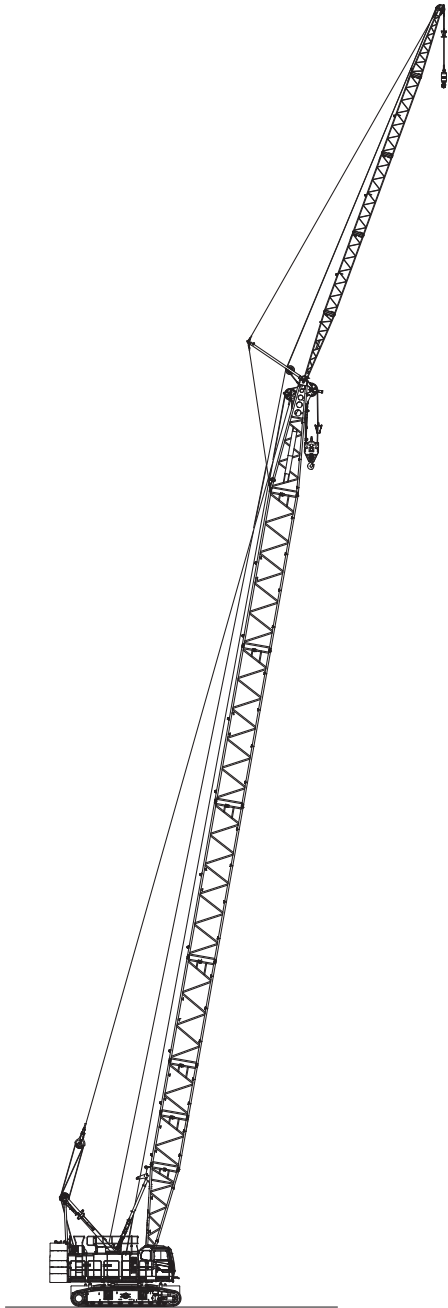

**Crane Specification  
(Boom Longest Length with Crane Jib)**

Boom Length	m	24 to 51
Crane Jib Length	m	10 to 28
Boom + Crane Jib Longest Length	m	51 + 28
Ground Contact Pressure	kPa (kgf/cm <sup>2</sup> )	125 (1.28) (Boom + crane jib longest length 35 t + 12 t hook attached)
Overall Operating Weight	t	Approximately 112 (Boom + crane jib longest length 35 t + 12 t hook attached)

## VARIATION

<b>Variation of The Attachment</b>	<b>2</b>
------------------------------------	----------

## SPECIFICATIONS

<b>Specifications</b>	<b>6</b>
-----------------------	----------

<b>Crane Specifications</b>	<b>7</b>
-----------------------------	----------

<b>Dimensions and Specifications</b> .....	<b>7</b>
--	----------

<b>Boom and Crane Jib Configurations</b> .....	<b>8</b>
--	----------

<b>Combination of Boom and Crane Jib (Offset Angle 10° and 30°)</b> .....	<b>9</b>
---	----------

<b>Working Ranges</b> .....	<b>10</b>
-----------------------------	-----------

■ Main Boom .....	10
-------------------	----

■ Aux. Sheave .....	11
---------------------	----

■ Main Boom with Aux. Sheave .....	12
------------------------------------	----

■ 10 m Crane Jib .....	13
------------------------	----

■ 16 m Crane Jib .....	14
------------------------	----

■ 22 m Crane Jib .....	15
------------------------	----

■ 28 m Crane Jib .....	16
------------------------	----

■ Main Boom with 10 m Crane Jib (Offset Angle 10°) .....	17
--	----

■ Main Boom with 10 m Crane Jib (Offset Angle 30°) .....	18
--	----

■ Main Boom with 16 m Crane Jib (Offset Angle 10°) .....	19
--	----

■ Main Boom with 16 m Crane Jib (Offset Angle 30°) .....	20
--	----

■ Main Boom with 22 m Crane Jib (Offset Angle 10°) .....	21
--	----

■ Main Boom with 22 m Crane Jib (Offset Angle 30°) .....	22
--	----

■ Main Boom with 28 m Crane Jib (Offset Angle 10°) .....	23
--	----

■ Main Boom with 28 m Crane Jib (Offset Angle 30°) .....	24
--	----

<b>Gross Rated Load Table</b> .....	<b>25</b>
-------------------------------------	-----------

■ Main Boom .....	25
-------------------	----

■ Aux. Sheave (Main Boom: 100 t Hook attached) .....	26
--	----

■ Aux. Sheave (Main Boom: 50 t Hook attached) .....	27
---	----

■ Aux. Sheave (Main Boom: 35 t Hook attached) .....	28
---	----

■ Aux. Sheave (Main Boom: No Hook attached) .....	29
---	----

- Main Boom with Aux. Sheave ..... 30
- Crane Jib ..... 31
- Main Boom with Crane Jib ..... 36
- Main Boom (Using Third Winch) ..... 41
- Main Boom with Aux. Sheave (Using Third Winch) ..... 42

**Clamshell Specifications 43**

---

- Dimensions and Specifications ..... 43**
  - Working Ranges ..... 43
  - Specifications ..... 43
  - Clamshell Bucket ..... 43
  - Gross Rated Load Table ..... 43

**TECHNICAL DATA**

**Weights and Dimensions of Disassembled Units 44**

---

- Weights and Dimensions List ..... 44

**Equipment List 48**

---

- Standard and Optional Equipment ..... 48
- Standard Equipment for European Specification Only ..... 50

# Specifications



## Engine

Model	Cummins B6.7
Type	4-cycle, Water-cooled, Direct injection, Turbo-charged, Diesel engine
Displacement	6.7 liters
Maximum Output	209 kW / 2,000 min <sup>-1</sup> (284 ps / 2,000 rpm)
Fuel Tank Capacity	450 liters
Notes	Compliant with the engine emissions regulations for EU Stage V. Engine rated horsepower is based on the international rating formula which includes necessary horsepower for engine alternator drive but excludes engine fan drive.



## Control

Control System	Main actuators are actuated by main hydraulic system controlled with pilot hydraulic system. Safety devices are securely operated by combined various electronic control with hydraulic system. Working speed can be precisely controlled according to control lever stroke and control dials depending on work.
Control Levers	Designed and positioned based on ergonomics. Arm-chair lever type is standard. Cross operation lever type and front lever type are available as option.
Display Panel Design	12.1 inches size touch panel. Located to check work state easily without disturbing the view of the operator.



## Hydraulic System

Hydraulic Oil Tank Capacity	320 liters		
Hydraulic Pump Capacity	Max.	31.4 MPa	
	P1	266 liters / min	for Front, Rear, boom hoist winch and travel
	P2	266 liters / min	for Front, Rear, third winch and travel
	P3	160 liters / min	for Swing, Jack, Sideframe retract and Gantry cyl.
	P4	41 liters / min	Pilot control, Brake cooling, Reeving tagline, etc.
	P5	41 liters / min	
	P6	41 liters / min	
P7	32 liters / min		



## Winch

Front and Rear Winch			
Winch	Front	Rear	
Rope Diameter	26 mm	26 mm	
Rope Length	Standard	205 m	125 m for Aux. sheave
	Winding Capacity	-	170 m for Crane jib
Line Pull	Rated	360 m	360 m
Standard Equipment	High-speed winching is possible by ECO winch mode with low engine speed under light loads.		
Optional Equipment	Free fall winch with brake controlled by pedal operation.		
Boom Hoist Winch			
Rope Diameter	22.4 mm		
Rope Length	Incorporated	160 m	
Hydraulic motor with multi-disc brakes.			

### Third Winch (Optional)

Rope Diameter	26 mm	
Rope Length	Standard	205 m
	Winding Capacity	220 m
Line Pull	Rated	117 kN
Free fall winch with brake controlled by pedal operation.		



## Swing System

Consisted of 2 hydraulic motors with reduction gear and multi-disc brakes and a swing bearing which has inner tooth. Optional swing brake pedal enables operator to control swing precisely.



## Gantry

Gantry is welded steel construction. Raised and lowered by power hydraulic cylinders.



## Counter Weight

Upper Weight	Total Weight	37.5 ton
	9.5 ton Base Weight	1 piece
	6.6 ton Insert Weight	2 pieces
	9.0 ton Insert Weight	1 piece
	2.8 ton Top Weight	1 piece
Lower Weight	3.0 ton Top Weight	1 piece
	Total Weight	12.0 ton
	6.0 ton Lower Weight	2 pieces



## Carbody Frame

Welded steel construction with jack up device and crawler sideframe extend-retract cylinders.



## Crawler Sideframe

Frame	Welded steel box construction, and can be retracted.	
Shoe	Cast iron 810 mm width shoe each side.	
Upper Roller	2 pieces double flange type for each side.	
Lower Roller	10 pieces each side.	
	Forging heat treated steel with double flange type. 2 plane bearing with floating seal for lifetime lubrication.	
Travel Device	1 peace each side.	
	Hydraulic travel device (Hydraulic motor and reducer)	
	Travel speed (Gradability : 30%)	High : 2.0 km/h Low : 1.1 km/h

# Crane Specifications

## Dimensions and Specifications

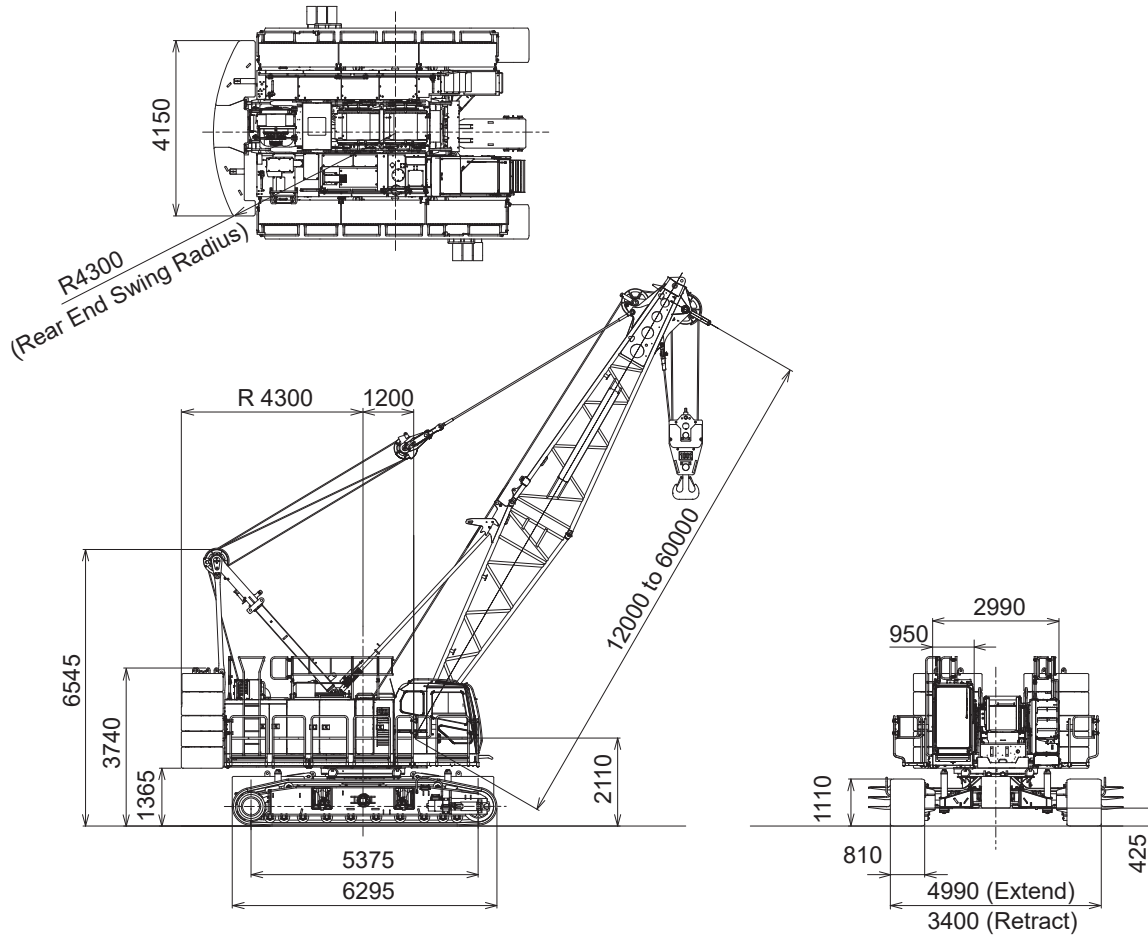

Crane Specifications		
Max. Lifting Load × Working Radius	t × m	100×3.8
Basic Boom Length	m	12
Max. Boom Length	m	60
Max. Crane Jib Length	m	10 to 28
Max. Boom + Jib Length	m	51 + 28
Ground Contact Pressure	kPa (kgf/cm <sup>2</sup> )	117 (1.20) (w / Basic Boom, 100 t Hook)
Overall Operating Weight	t	Approximately 104 (w / Basic Boom, 100 t Hook)

Hook Weight	
100 t	1,200 kg
50 t	1,170 kg
35 t	900 kg
12 t	510 kg

NOTE : Data is expressed in SI units followed by conventional units in ( ).

# Boom and Crane Jib Configurations

Boom	
Boom Length (m)	Boom Configurations
12	
15	
18	
21	
24	
27	
30	
33	
36	
39	
42	

Boom	
Boom Length (m)	Boom Configurations
45	
48	
51	
54	
57	
60	

Aux. Sheave Installable Boom Length																	
Boom Length (m)	12	15	18	21	24	27	30	33	36	39	42	45	48	51	54	57	60
With Aux. Sheave	○	○	○	○	○	○	○	○	○	○	○	○	○	○	○	○	×

(○: Attachable ×: Not Attachable)

Check the pendant rope with referring to the imprints on the rope end.

Dimensions Not Shown In The Figure		Pendant Rope		
Symbols	Boom Length (m)	Length (m)	Rope Diameter (mm)	Imprint
3	3	3	35.5	□ • △ • 35.5 • 3 • C
6	6	5.3	35.5	□ • △ • 35.5 • 5.3 • C
9	9	6	35.5	□ • △ • 35.5 • 6 • C
		9	35.5	□ • △ • 35.5 • 9 • C

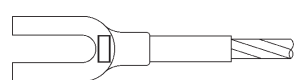



# Combination of Boom and Crane Jib (Offset Angle 10° and 30°)

Combination of Boom and Crane Jib (Offset Angle 10° and 30°)																		
Boom Length (m)	12	15	18	21	24	27	30	33	36	39	42	45	48	51	54	57	60	
Jib Length (m)	10	×	×	×	×	○	○	○	○	○	○	○	○	○	×	×	×	
	16	×	×	×	×	○	○	○	○	○	○	○	○	○	×	×	×	
	22	×	×	×	×	○	○	○	○	○	○	○	○	○	×	×	×	
	28	×	×	×	×	○	○	○	○	○	○	○	○	○	×	×	×	

( ○ : Attachable × : Not Attachable )

Crane Jib (Offset Angle 10° and 30°)		
Crane Jib Length (m)	Offset Angle	Crane Jib Configurations
10	10°	
	30°	
16	10°	
	30°	
22	10°	
	30°	
28	10°	
	30°	

Check the pendant rope with referring to the imprints on the rope end.

Dimensions Not Shown In The Figure	
Symbols	Jib Length (m)
5	5
6	6

Jib Pendant Rope			
Length (m)	Rope Diameter (mm)	Imprint	
1.6	24	□ · △ · 24 · 1.6 · S	
5.7	24	□ · △ · 24 · 5.7 · S	
8.3	24	□ · △ · 24 · 8.3 · S	
9.6	24	□ · △ · 24 · 9.6 · S	

# Working Ranges

## ■ Main Boom

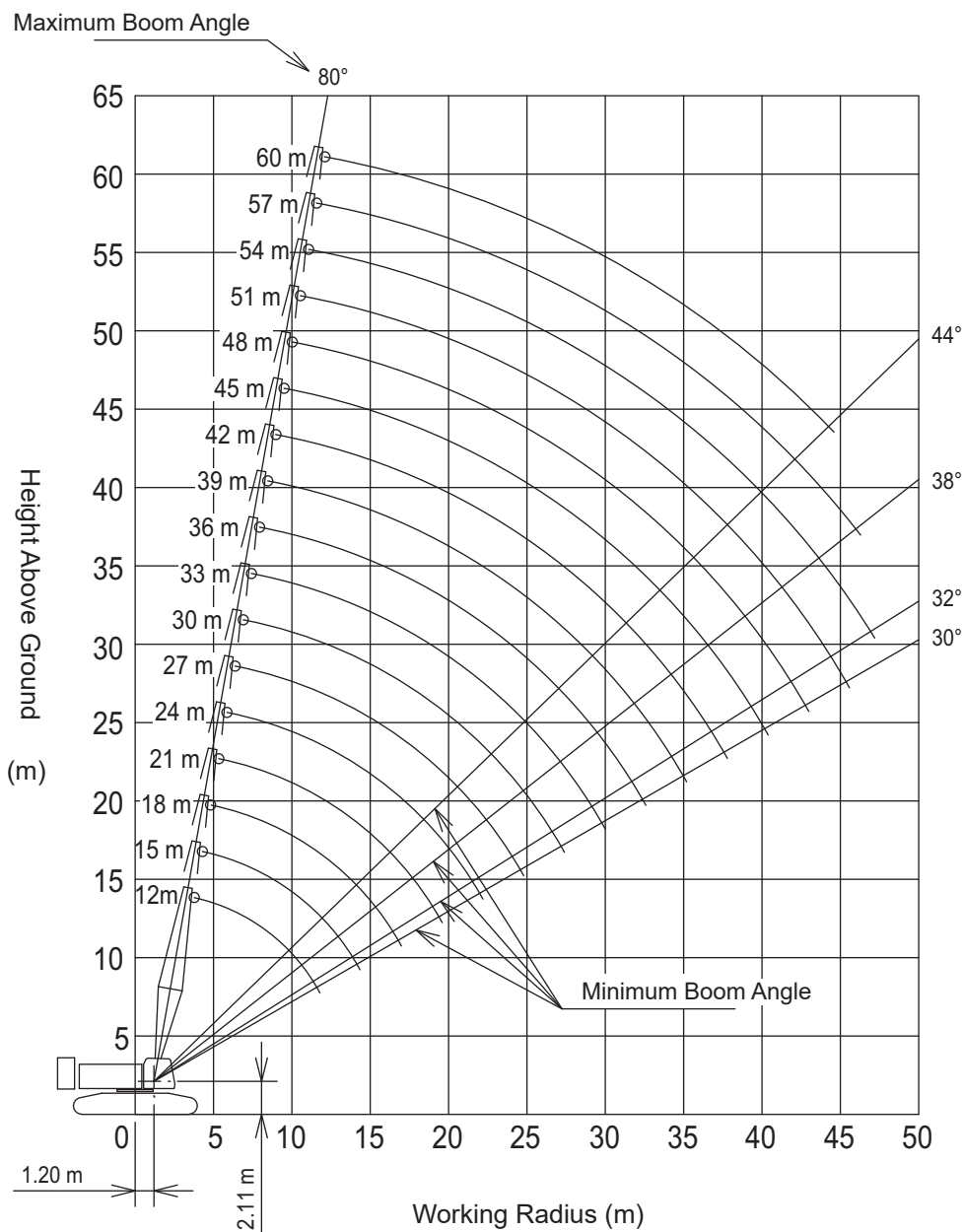
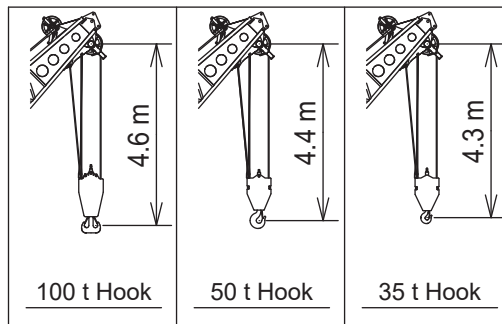

■ Aux. Sheave

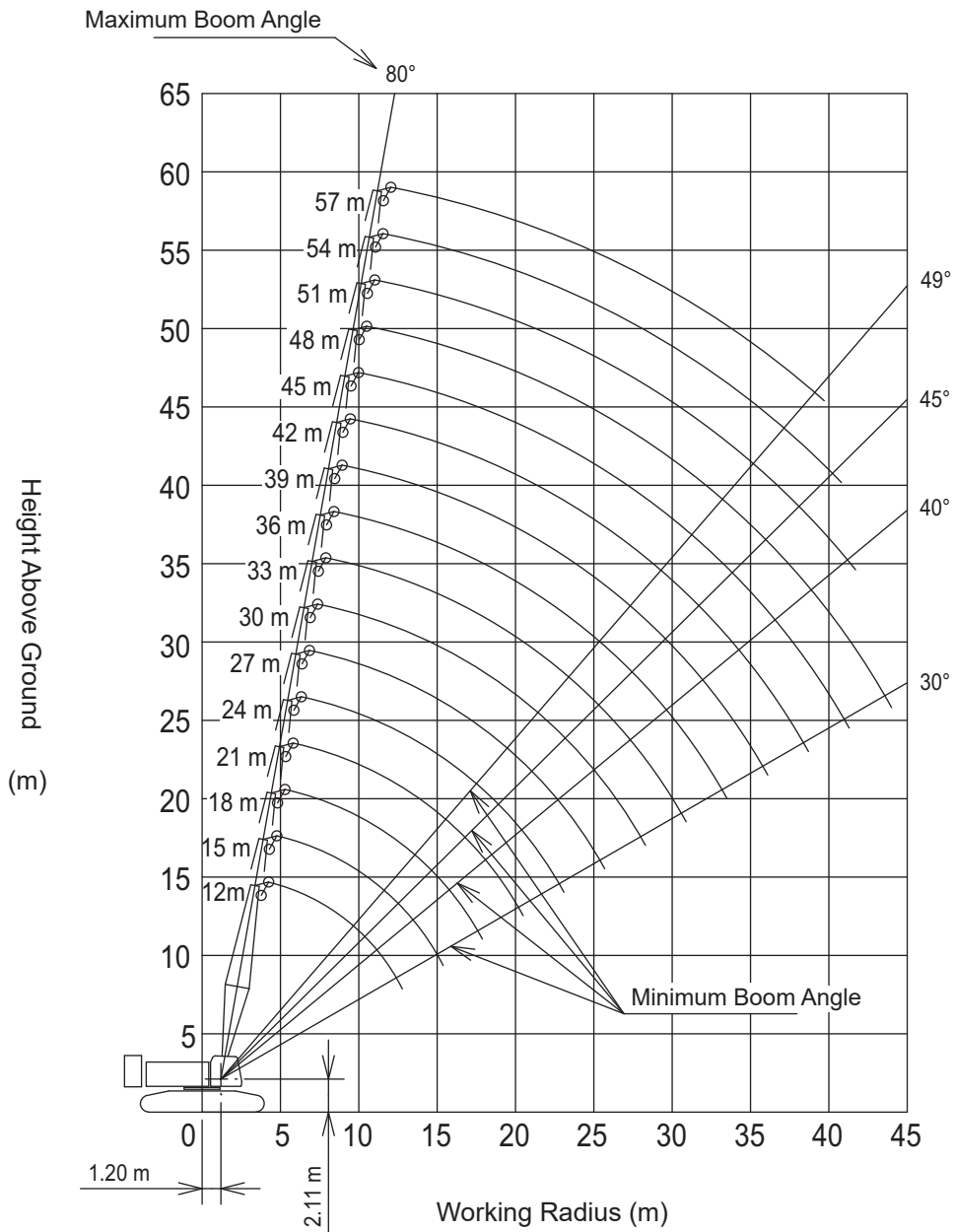
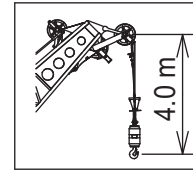

■ Main Boom with Aux. Sheave

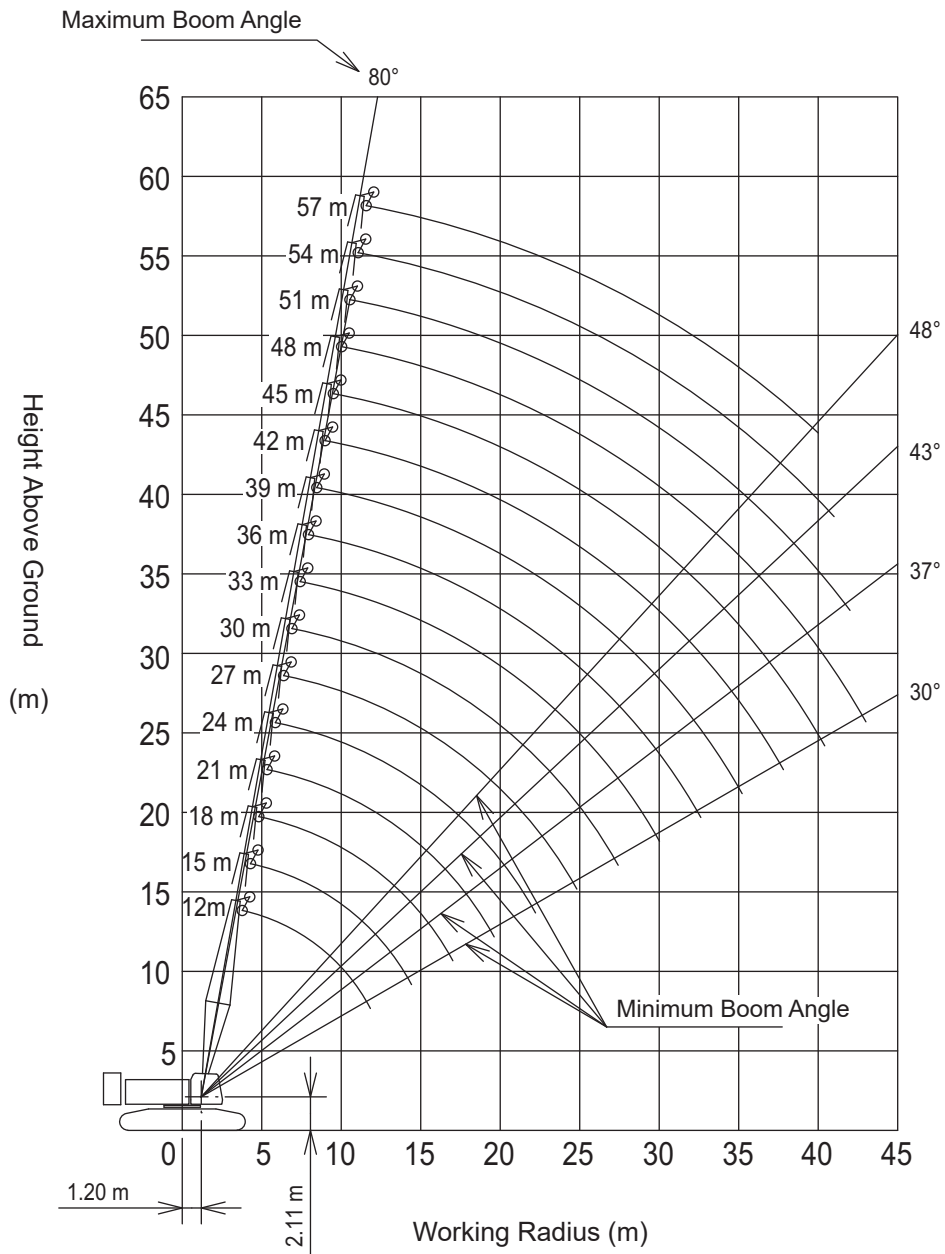
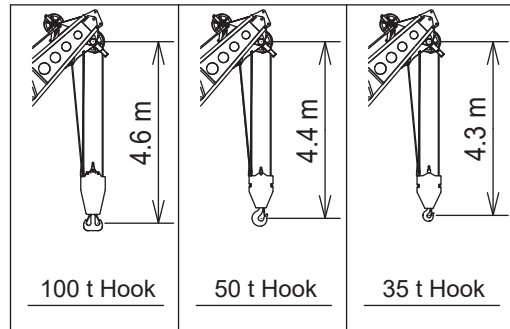

10 m Crane Jib

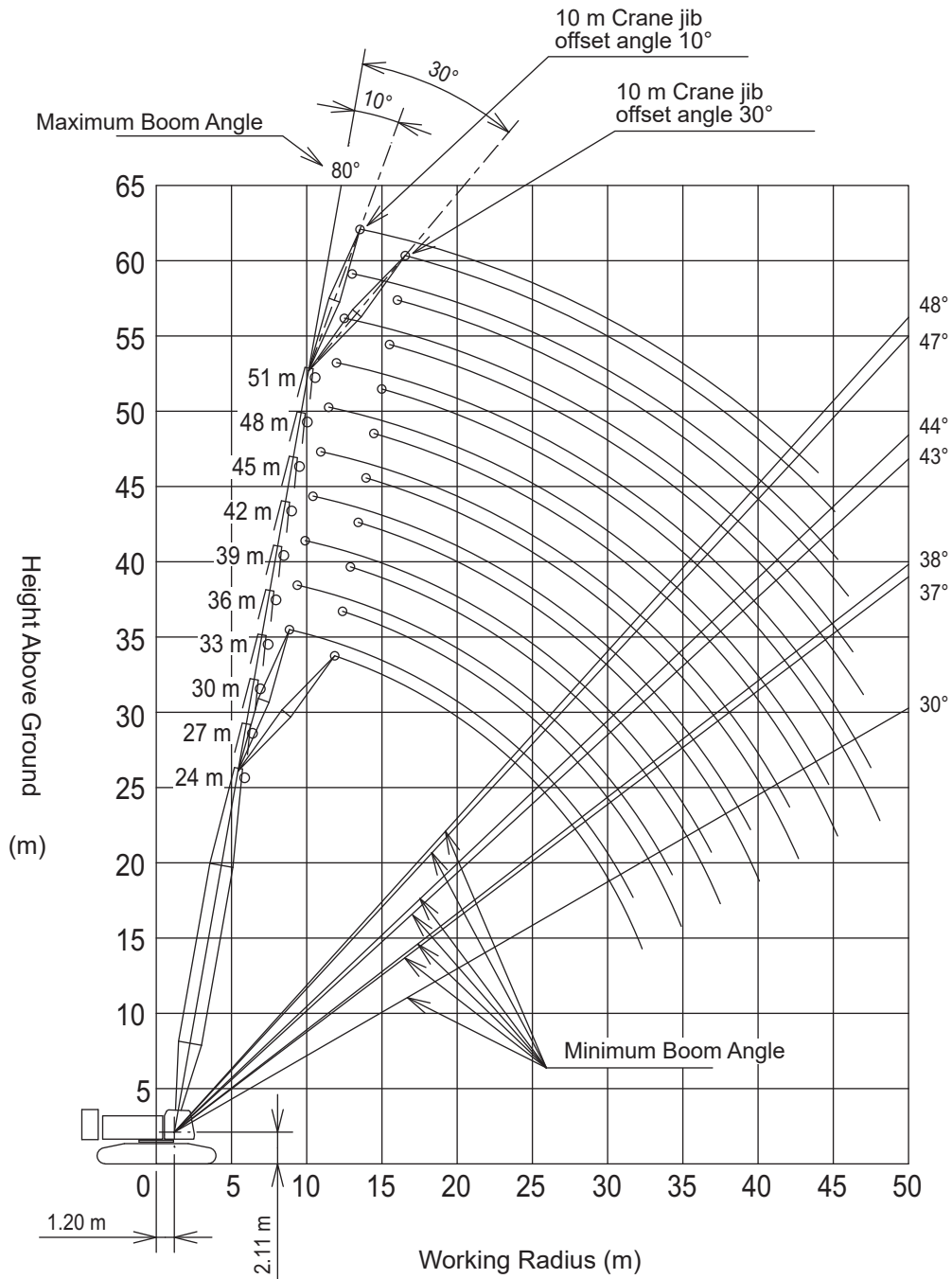
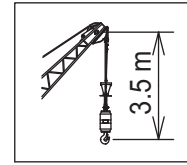

16 m Crane Jib

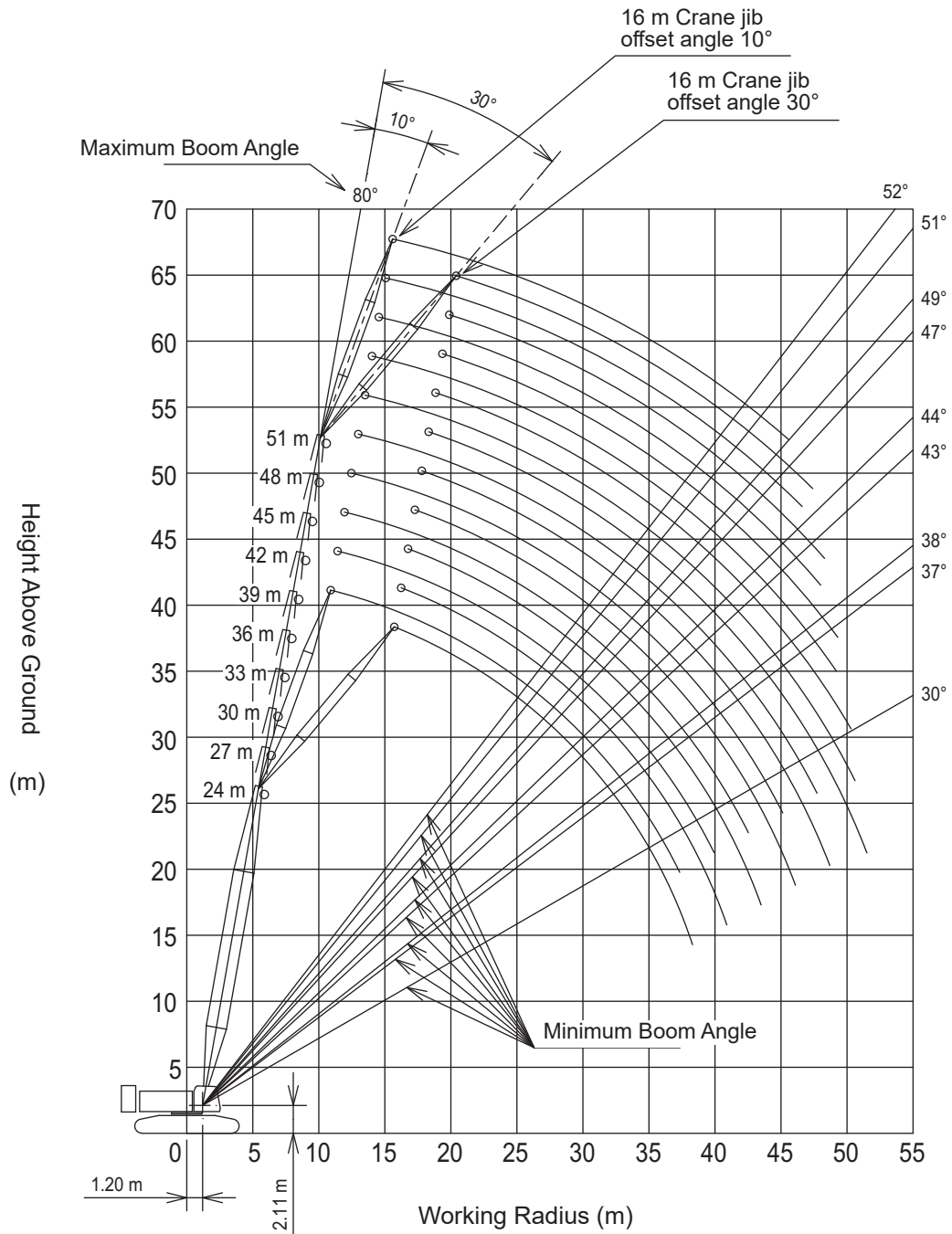
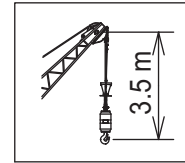

22 m Crane Jib

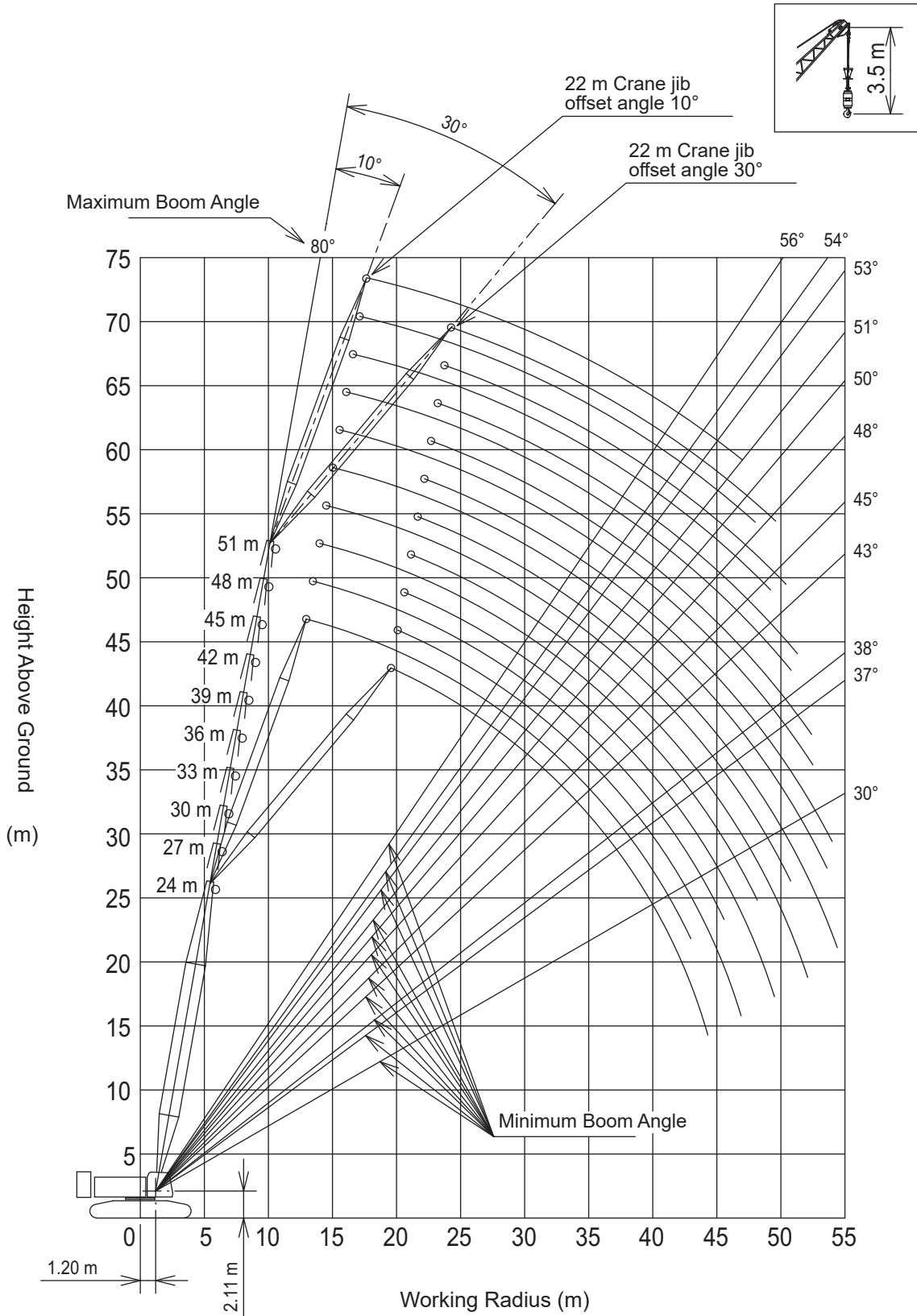

28 m Crane Jib

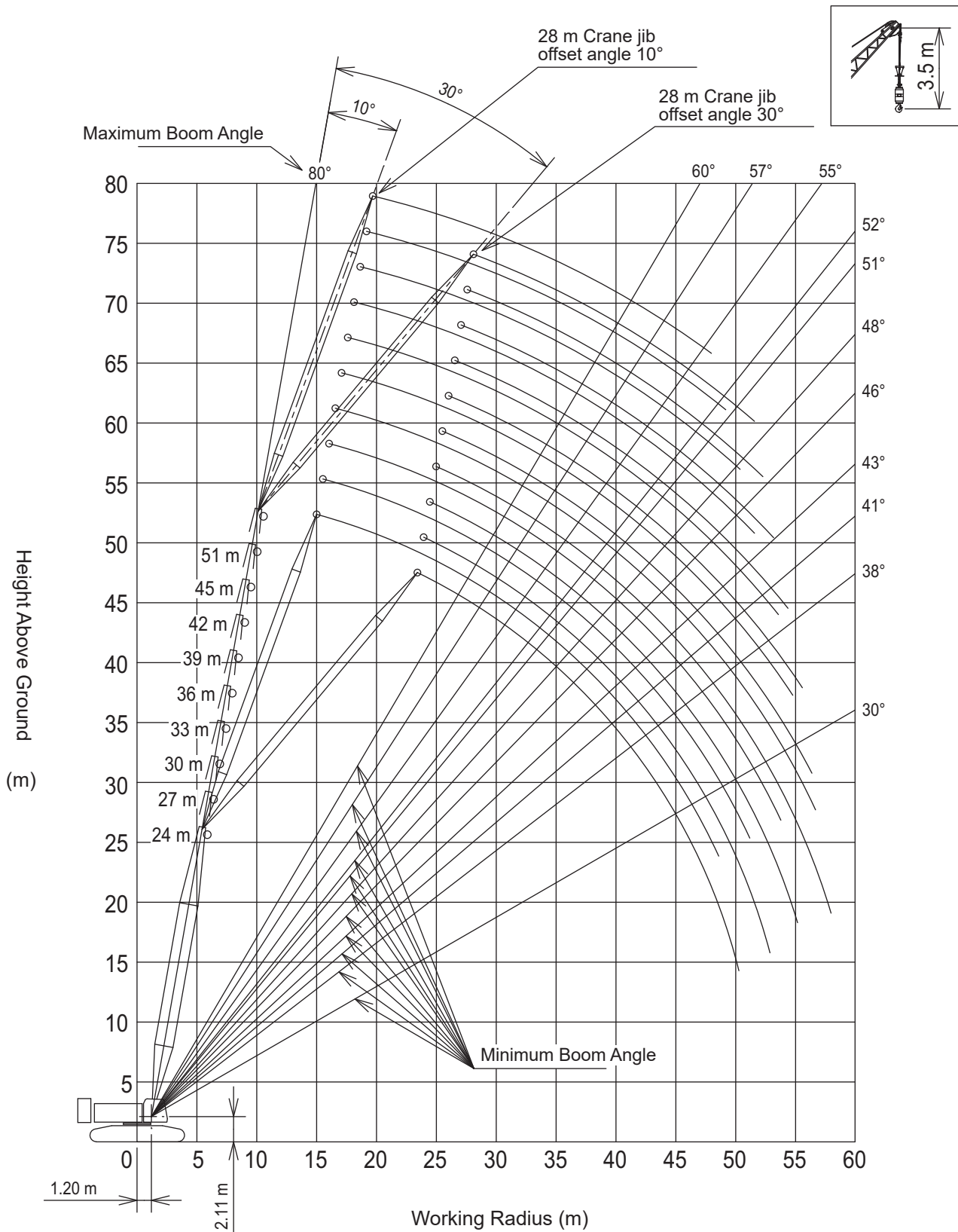



■ Main Boom with 10 m Crane Jib (Offset Angle 10°)

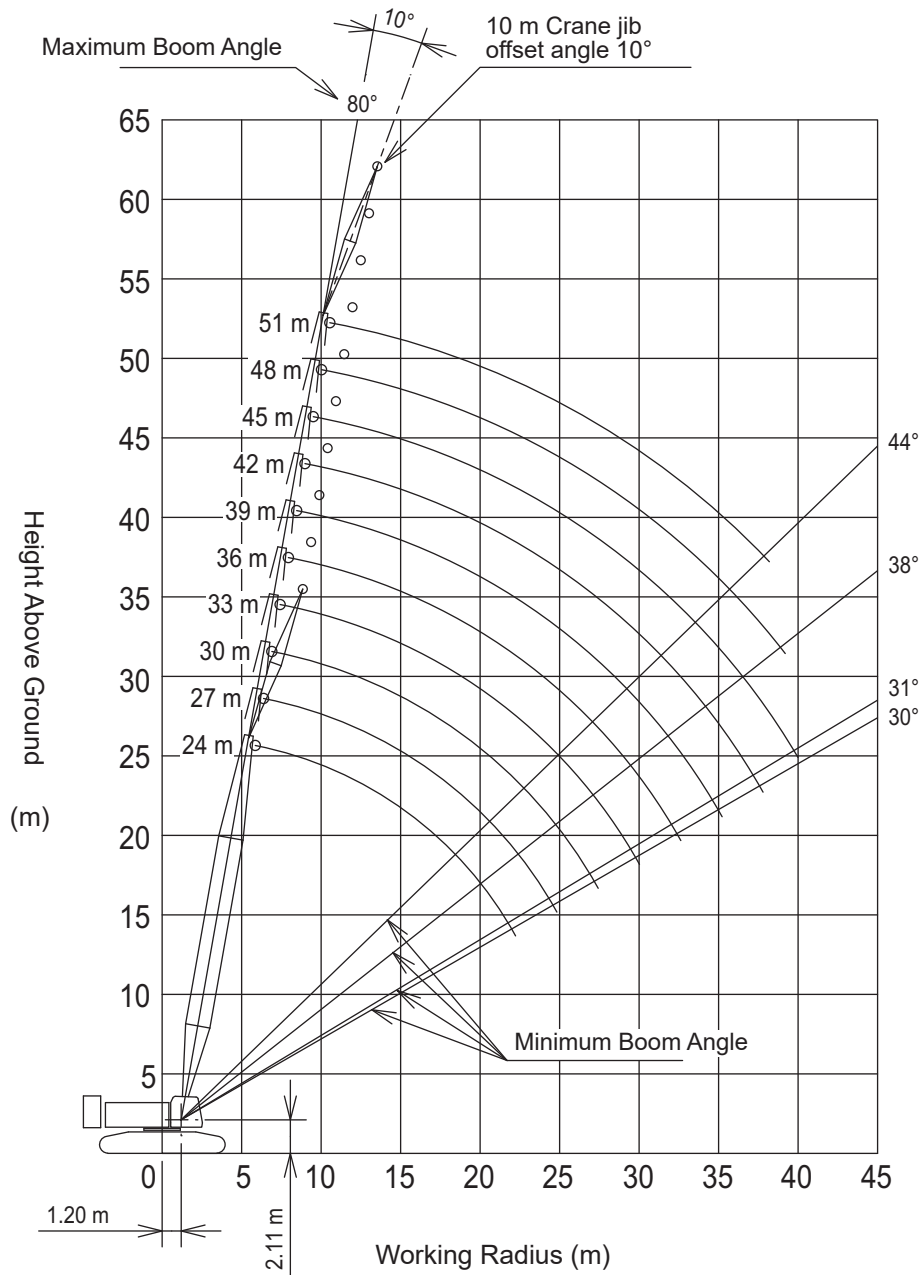
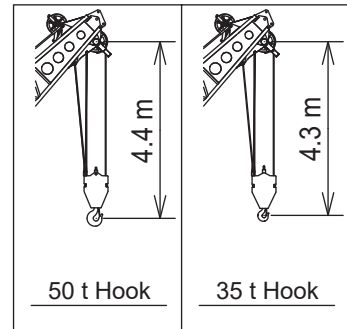

■ Main Boom with 10 m Crane Jib (Offset Angle 30°)

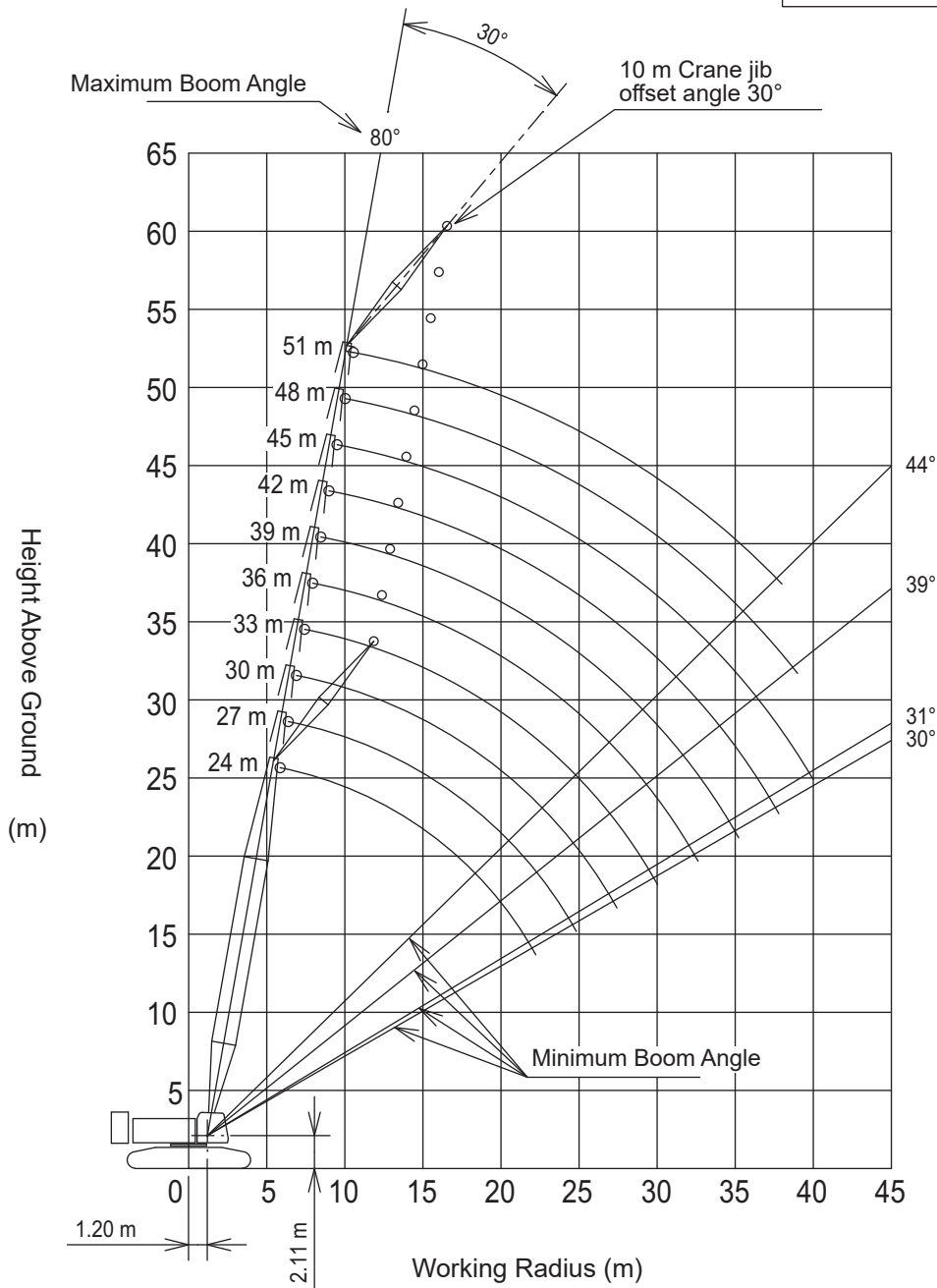
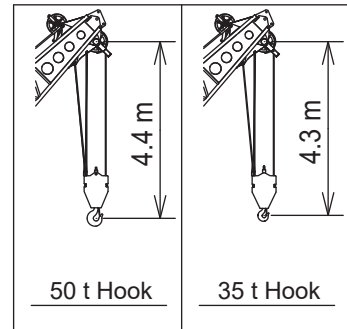

■ Main Boom with 16 m Crane Jib (Offset Angle 10°)

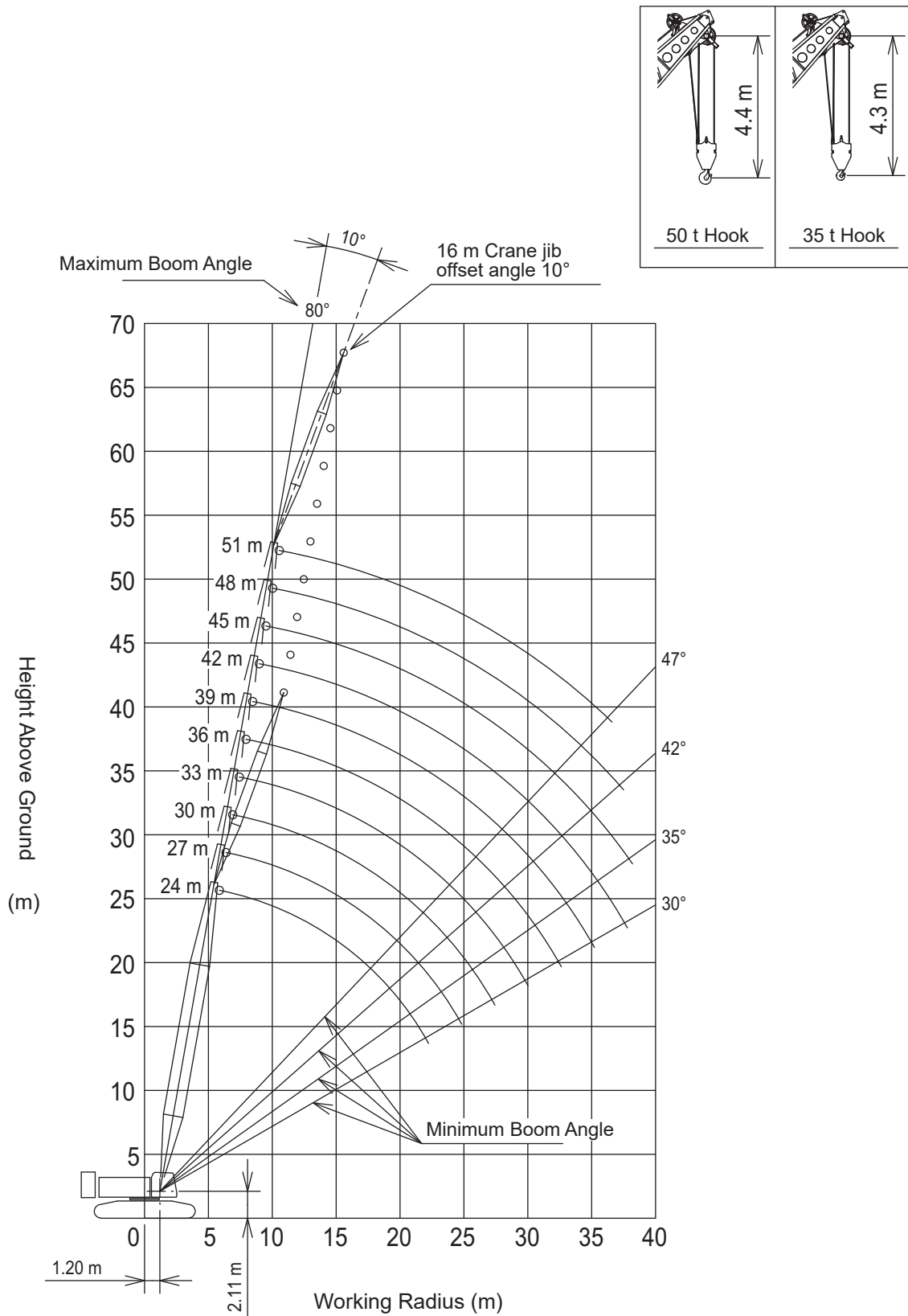

■ Main Boom with 16 m Crane Jib (Offset Angle 30°)

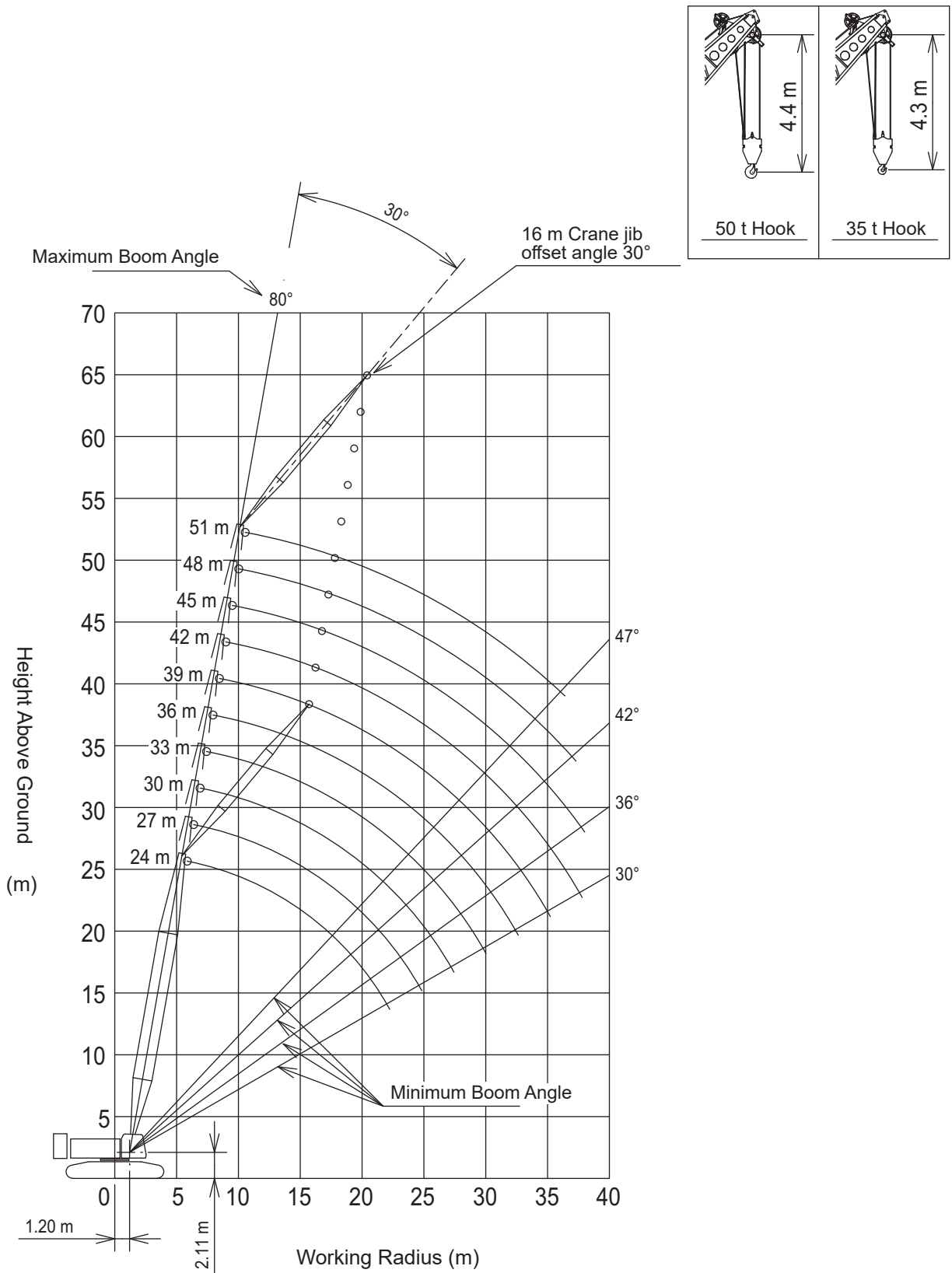

■ Main Boom with 22 m Crane Jib (Offset Angle 10°)

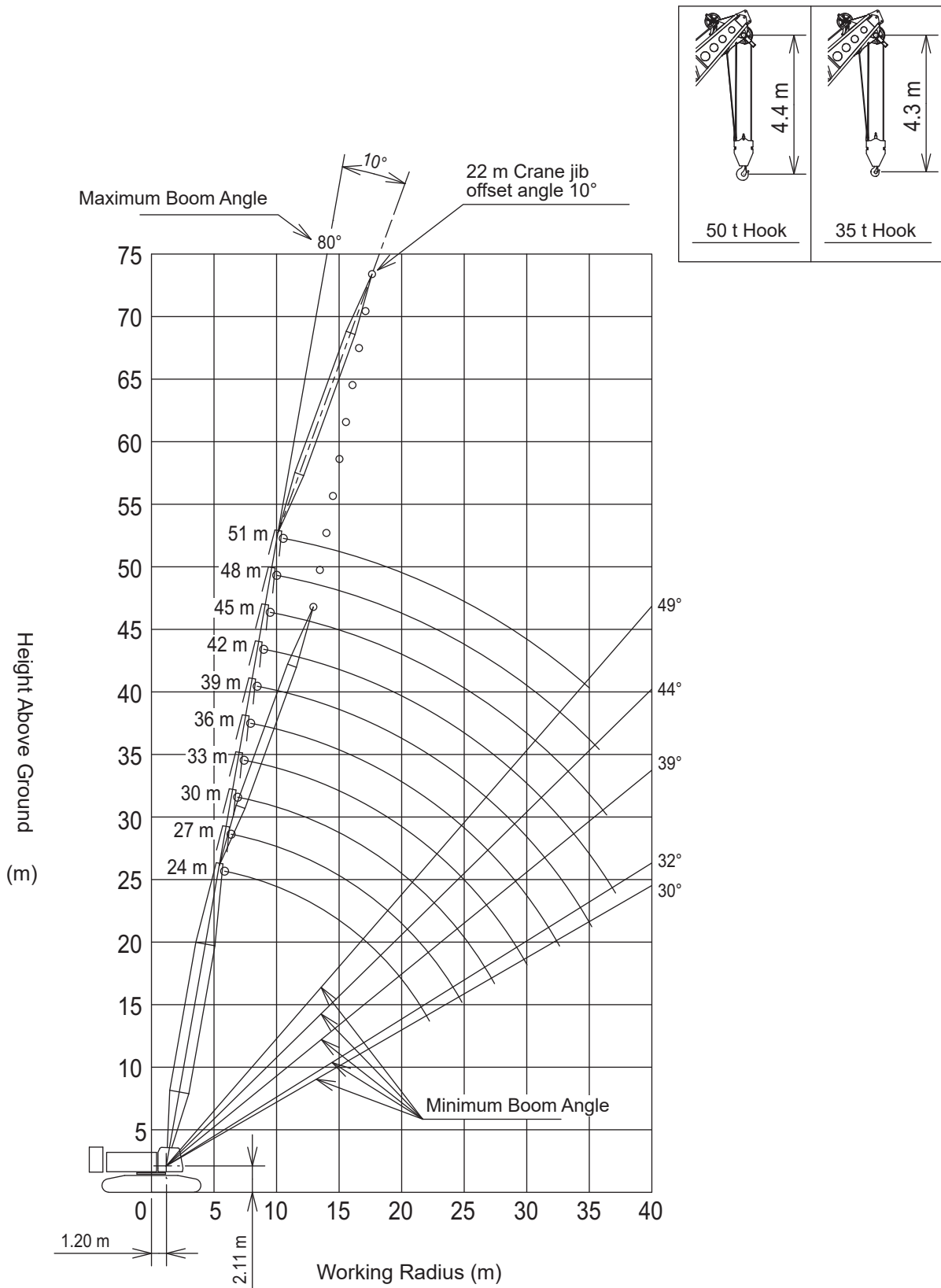

■ Main Boom with 22 m Crane Jib (Offset Angle 30°)

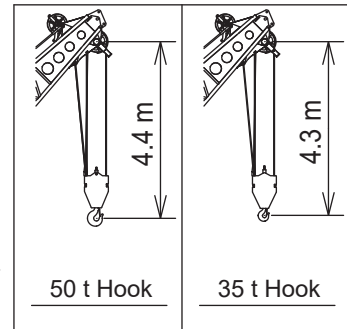
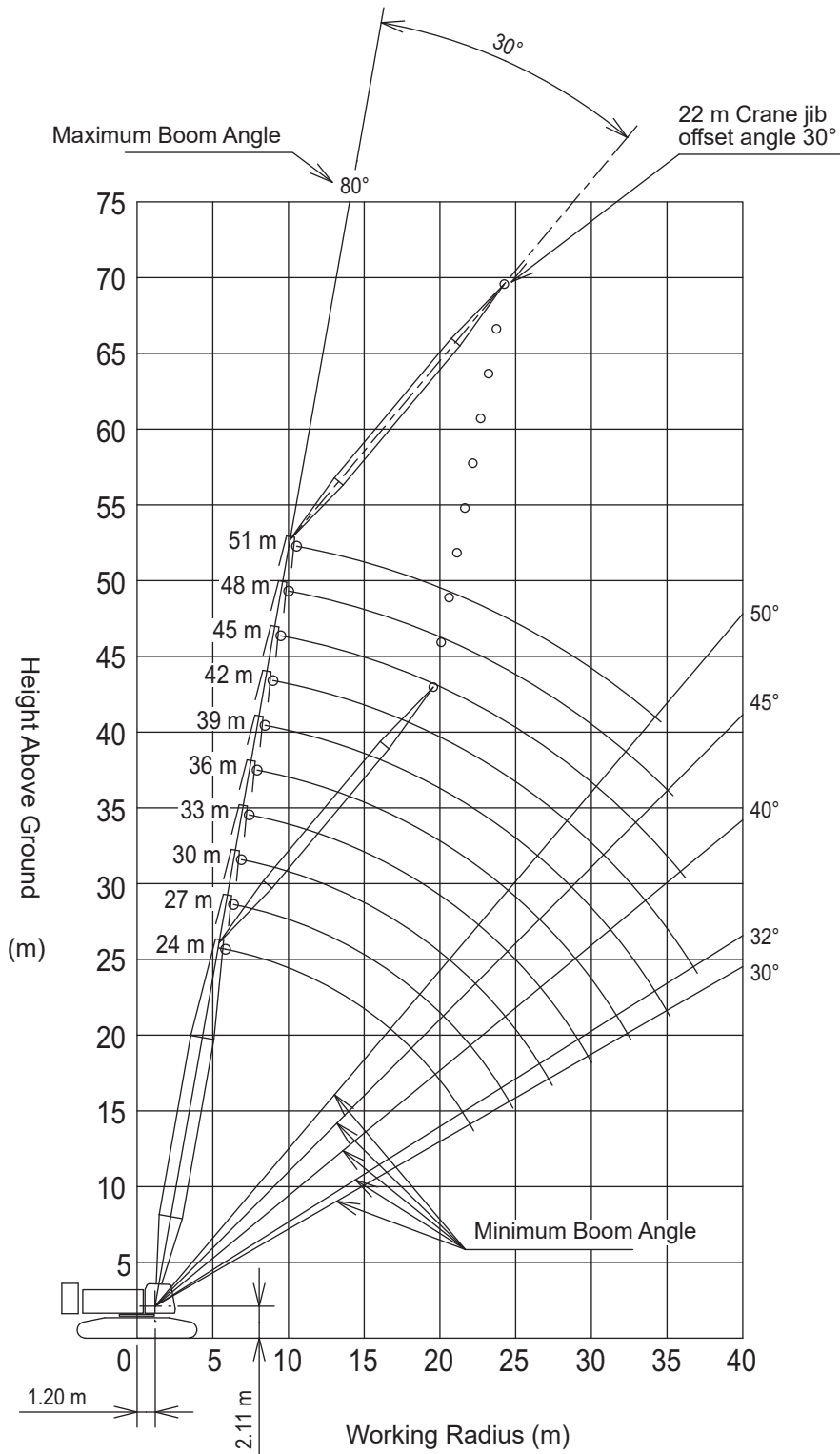

■ Main Boom with 28 m Crane Jib (Offset Angle 10°)

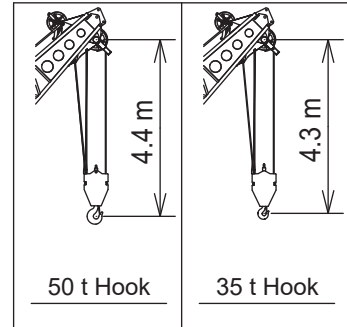
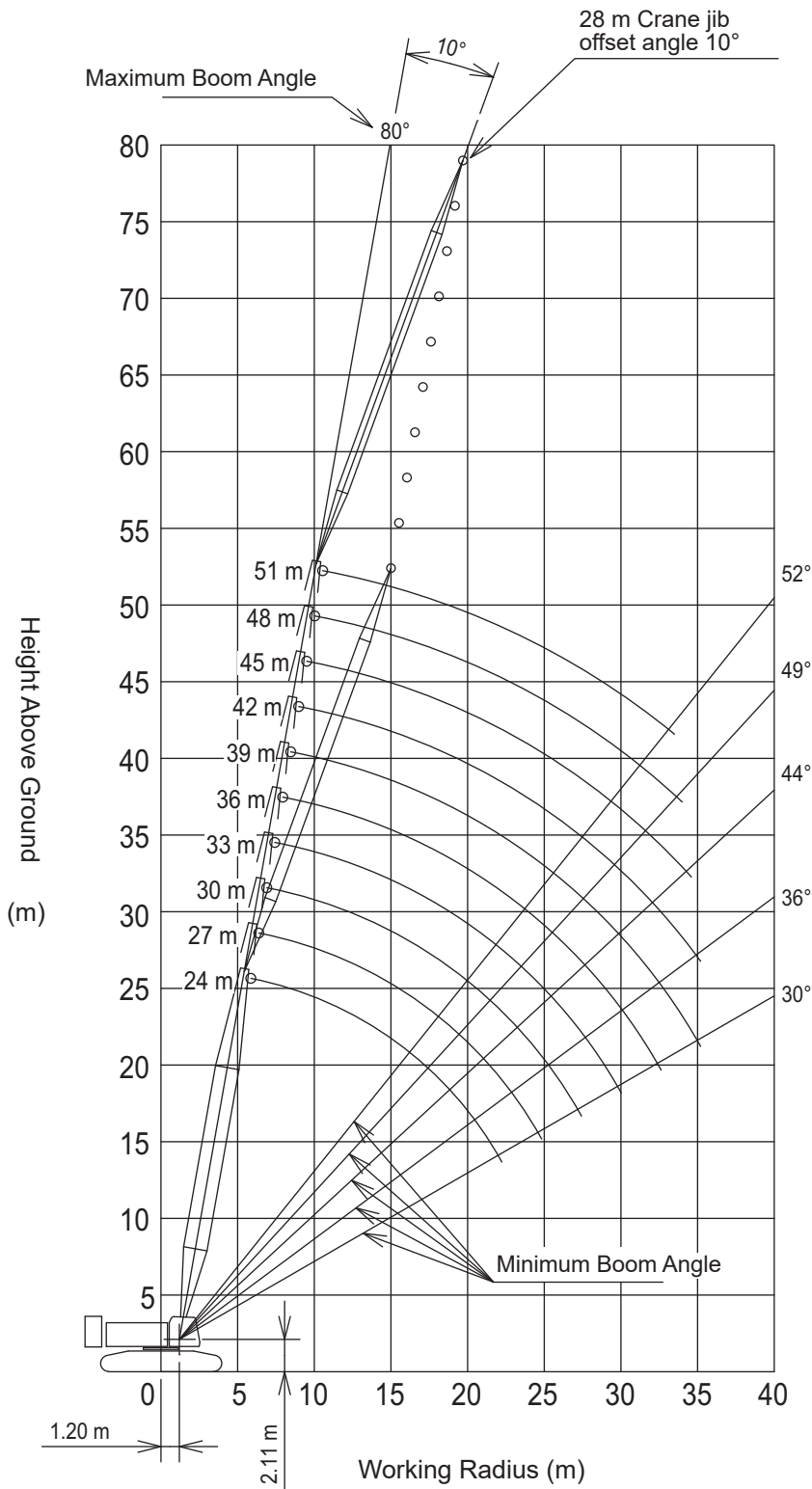

■ Main Boom with 28 m Crane Jib (Offset Angle 30°)

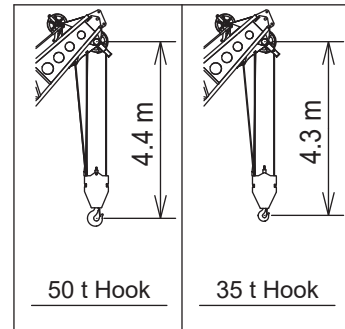
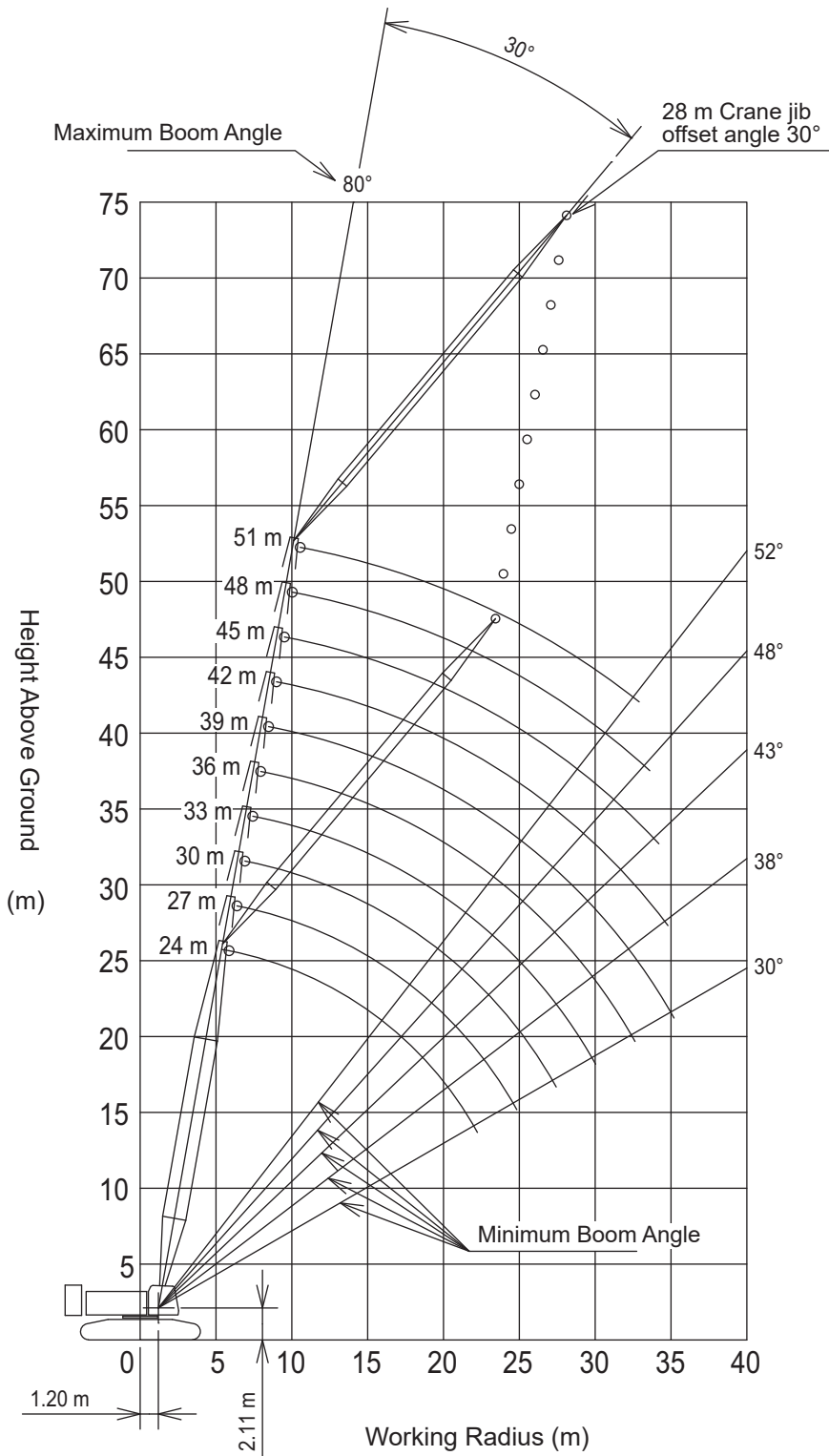



# Gross Rated Load Table

## Main Boom



Unit: ton loads /working radius

Working Radius(m)	Boom Length (m)										Working Radius(m)
	12	15	18	21	24	27	30	33	36	39	
3.8	100.00										3.8
4.0	94.95										4.0
4.5	84.40	84.40									4.5
5.0	75.95	75.95	75.95								5.0
5.5	69.05	69.05	68.80	65.70 /5.6							5.5
6.0	63.30	63.30	62.85	60.75	57.25 /6.1	49.85 /6.7					6.0
7.0	54.10	54.10	53.00	51.15	49.30	47.60	44.65 /7.2	39.65 /7.8			7.0
8.0	44.90	44.90	44.75	44.05	42.60	41.25	39.95	38.65	36.00 /8.3	32.95 /8.8	8.0
9.0	38.10	38.05	37.90	37.85	37.45	36.35	35.30	34.15	33.15	32.20	9.0
10.0	33.00	32.90	32.75	32.70	32.60	32.40	31.55	30.55	29.70	28.90	10.0
12.0	26.50 /11.8	25.80	25.60	25.55	25.40	25.35	25.15	25.00	24.40	23.80	12.0
14.0		21.10	20.90	20.80	20.65	20.60	20.40	20.25	20.00	20.00	14.0
16.0		20.30 /14.4	17.55	17.45	17.25	17.20	17.00	16.85	16.60	16.55	16.0
18.0			16.20 /17.0	14.90	14.75	14.65	14.45	14.30	14.05	14.00	18.0
20.0				13.35 /19.6	12.80	12.70	12.50	12.30	12.05	12.05	20.0
22.0					11.25	11.10	10.90	10.70	10.50	10.45	22.0
24.0					11.10 /22.2	9.85	9.65	9.45	9.20	9.15	24.0
26.0						9.40 /24.8	8.60	8.35	8.15	8.10	26.0
28.0							7.95 /27.4	7.45	7.25	7.15	28.0
30.0								6.70	6.45	6.40	30.0
32.0									5.80	5.75	32.0
34.0									5.60 /32.6	5.15	34.0
36.0										4.85 /35.2	36.0

Unit: ton loads /working radius

Working Radius(m)	Boom Length (m)								Working Radius(m)
	42	45	48	51	54	57	60		
9.0	29.90 /9.4	27.60 /9.9						9.0	
10.0	28.05	27.35	25.35 /10.5	22.45 /11.1	19.35 /11.6			10.0	
12.0	23.15	22.60	22.05	21.35	19.15	18.05 /12.2	14.55 /12.7	12.0	
14.0	19.50	19.05	18.65	18.05	17.60	17.15	14.10	14.0	
16.0	16.35	16.20	16.00	15.45	15.10	14.70	13.40	16.0	
18.0	13.80	13.65	13.50	13.40	13.05	12.75	12.35	18.0	
20.0	11.80	11.65	11.50	11.40	11.25	11.15	10.75	20.0	
22.0	10.20	10.05	9.95	9.80	9.65	9.55	9.30	22.0	
24.0	8.90	8.75	8.65	8.50	8.35	8.20	8.00	24.0	
26.0	7.85	7.70	7.55	7.40	7.25	7.15	6.90	26.0	
28.0	6.95	6.80	6.65	6.50	6.35	6.20	6.00	28.0	
30.0	6.15	6.00	5.85	5.70	5.55	5.40	5.20	30.0	
32.0	5.50	5.35	5.20	5.05	4.90	4.75	4.50	32.0	
34.0	4.90	4.75	4.60	4.45	4.30	4.15	3.90	34.0	
36.0	4.40	4.25	4.10	3.90	3.75	3.60	3.40	36.0	
38.0	4.00 /37.8	3.80	3.65	3.45	3.30	3.15	2.90	38.0	
40.0		3.40	3.25	3.05	2.90	2.75	2.50	40.0	
42.0		3.30 /40.4	2.85	2.65	2.50	2.35	2.15	42.0	
44.0			2.70 /43.0	2.35	2.20	2.05	1.80	44.0	
46.0				2.15 /45.3	1.90	1.75	1.70 /44.6	46.0	
48.0					1.70 /47.2	1.70 /46.3		48.0	

- The rated loads are determined according to EN13000 rating on the condition that the machine is stationed on firm, level ground.
- The figures surrounded by bold lines are based on factors other than those which would cause a tipping condition.
- To calculate the maximum load that can actually be lifted, deduct weight of all lifting accessories, such as boom hook and jib hook, from figures shown above.
- Working radius is the horizontal distance from the slewing center to the center of gravity of a lifted load.
- The counter weight is 49.5 tons. (Upper weight 37.5 tons + Lower weight 12.0 tons)
- Correlation between the number of reeved lines, maximum rated loads, hook weights are shown in the table below.

Hook Capacity (t)	Hook Weight (t)	Maximum Rated Loads (t)							
		8 falls	7 falls	6 falls	5 falls	4 falls	3 falls	2 falls	1 fall
100	1.20	100	84	72	60	48	-	-	-
50	1.17	-	-	-	50	48	36	24	-
35	0.90	-	-	-	-	-	35	24	-
12	0.51	-	-	-	-	-	-	-	12

- When performing repetitive work using buckets, lifting magnets, etc., the higher the load factor, the shorter the life of the structure (boom, frame, winch, etc.).

■ Aux. Sheave (Main Boom: 100 t Hook attached)



Unit: ton loads /working radius

Working Radius(m)	Boom Length (m)										Working Radius(m)	
	12	15	18	21	24	27	30	33	36	39		
4.6	12.00											4.6
5.0	12.00	12.00 /5.3										5.0
5.5	12.00	12.00	12.00 /5.8									5.5
6.0	12.00	12.00	12.00	12.00 /6.3	12.00 /6.9							6.0
7.0	12.00	12.00	12.00	12.00	12.00	12.00 /7.4						7.0
8.0	12.00	12.00	12.00	12.00	12.00	12.00	12.00	12.00 /8.5				8.0
9.0	12.00	12.00	12.00	12.00	12.00	12.00	12.00	12.00	12.00 /9.1	12.00 /9.6		9.0
10.0	12.00	12.00	12.00	12.00	12.00	12.00	12.00	12.00	12.00	12.00	12.00	10.0
12.0	12.00	12.00	12.00	12.00	12.00	12.00	12.00	12.00	12.00	12.00	12.00	12.0
14.0	12.00 /13.1	12.00	12.00	12.00	12.00	12.00	12.00	12.00	12.00	12.00	12.00	14.0
16.0		12.00 /15.7	12.00	12.00	12.00	12.00	12.00	12.00	12.00	12.00	12.00	16.0
18.0			12.00	12.00	12.00	12.00	12.00	12.00	12.00	12.00	12.00	18.0
20.0			12.00 /18.2	11.55	11.10	10.90	10.80	10.80	10.60	10.55	10.55	20.0
22.0				10.90 /20.8	9.80	9.65	9.45	9.25	9.00	8.95	8.95	22.0
24.0					8.90 /23.4	8.40	8.15	7.95	7.70	7.65	7.65	24.0
26.0						7.30	7.10	6.90	6.65	6.60	6.60	26.0
28.0							6.20	6.00	5.75	5.65	5.65	28.0
30.0							6.00 /28.6	5.20	4.95	4.90	4.90	30.0
32.0								4.80 /31.2	4.30	4.20	4.20	32.0
34.0									3.80 /33.8	3.65	3.65	34.0
36.0										3.10	3.10	36.0
38.0										3.05 /36.4	3.05 /36.4	38.0

Unit: ton loads /working radius

Working Radius(m)	Boom Length (m)						Working Radius(m)
	42	45	48	51	54	57	
10.0	12.00 /10.2	12.00 /10.7	12.00 /11.3	12.00 /11.8			10.0
12.0	12.00	12.00	12.00	12.00	12.00 /12.4	12.00 /12.9	12.0
14.0	12.00	12.00	12.00	12.00	12.00	12.00	14.0
16.0	12.00	12.00	12.00	12.00	12.00	12.00	16.0
18.0	12.00	11.75	11.70	11.50	11.05	10.80	18.0
20.0	10.35	10.15	10.05	9.90	9.60	9.25	20.0
22.0	8.70	8.55	8.40	8.30	8.15	7.90	22.0
24.0	7.40	7.25	7.10	7.00	6.85	6.70	24.0
26.0	6.35	6.15	6.00	5.90	5.75	5.60	26.0
28.0	5.40	5.25	5.10	4.95	4.80	4.65	28.0
30.0	4.65	4.45	4.30	4.20	4.00	3.85	30.0
32.0	3.95	3.80	3.65	3.50	3.35	3.20	32.0
34.0	3.35	3.20	3.05	2.90	2.75	2.60	34.0
36.0	2.85	2.70	2.55	2.40	2.20	2.05	36.0
38.0	2.40	2.25	2.05	1.90	1.75	1.60	38.0
40.0	2.20 /39.0	1.85	1.65	1.50	1.55 /39.0		40.0
42.0		1.55 /41.6	1.45 /41.0				42.0

1. The rated loads are determined according to EN13000 rating on the condition that the machine is stationed on firm, level ground.
2. The figures surrounded by bold lines are based on factors other than those which would cause a tipping condition.
3. To calculate the maximum load that can actually be lifted, deduct the weight of hooks and lifting accessories other than the main hook from the figures shown above.
4. Working radius is the horizontal distance from the slewing center to the center of gravity of a lifted load.
5. The counter weight is 49.5 tons. (Upper weight 37.5 tons + Lower weight 12.0 tons)
6. Hook weight are shown in the table below.

Hook Capacity (t)	Hook Weight (t)
12	0.51

■ Aux. Sheave (Main Boom: 50 t Hook attached)



Unit: ton loads /working radius

Working Radius(m)	Boom Length (m)										Working Radius(m)	
	12	15	18	21	24	27	30	33	36	39		
4.6	12.00											4.6
5.0	12.00	12.00 /5.3										5.0
5.5	12.00	12.00	12.00 /5.8									5.5
6.0	12.00	12.00	12.00	12.00 /6.3	12.00 /6.9							6.0
7.0	12.00	12.00	12.00	12.00	12.00	12.00 /7.4						7.0
8.0	12.00	12.00	12.00	12.00	12.00	12.00	12.00	12.00 /8.5				8.0
9.0	12.00	12.00	12.00	12.00	12.00	12.00	12.00	12.00	12.00 /9.1	12.00 /9.6		9.0
10.0	12.00	12.00	12.00	12.00	12.00	12.00	12.00	12.00	12.00	12.00	12.00	10.0
12.0	12.00	12.00	12.00	12.00	12.00	12.00	12.00	12.00	12.00	12.00	12.00	12.0
14.0	12.00 /13.1	12.00	12.00	12.00	12.00	12.00	12.00	12.00	12.00	12.00	12.00	14.0
16.0		12.00 /15.7	12.00	12.00	12.00	12.00	12.00	12.00	12.00	12.00	12.00	16.0
18.0			12.00	12.00	12.00	12.00	12.00	12.00	12.00	12.00	12.00	18.0
20.0			12.00 /18.2	11.55	11.10	10.95	10.85	10.85	10.65	10.60	10.60	20.0
22.0				10.95 /20.8	9.85	9.70	9.50	9.30	9.05	9.00	9.00	22.0
24.0					8.95 /23.4	8.45	8.20	8.00	7.75	7.70	7.70	24.0
26.0						7.35	7.15	6.95	6.70	6.65	6.65	26.0
28.0							6.25	6.05	5.80	5.70	5.70	28.0
30.0							6.05 /28.6	5.25	5.00	4.95	4.95	30.0
32.0								4.85 /31.2	4.35	4.25	4.25	32.0
34.0									3.85 /33.8	3.70	3.70	34.0
36.0										3.15	3.15	36.0
38.0										3.10 /36.4	3.10	38.0

Unit: ton loads /working radius

Working Radius(m)	Boom Length (m)						Working Radius(m)
	42	45	48	51	54	57	
10.0	12.00 /10.2	12.00 /10.7	12.00 /11.3	12.00 /11.8			10.0
12.0	12.00	12.00	12.00	12.00	12.00 /12.4	12.00 /12.9	12.0
14.0	12.00	12.00	12.00	12.00	12.00	12.00	14.0
16.0	12.00	12.00	12.00	12.00	12.00	12.00	16.0
18.0	12.00	11.80	11.75	11.55	11.10	10.85	18.0
20.0	10.40	10.20	10.10	9.95	9.65	9.30	20.0
22.0	8.75	8.60	8.45	8.35	8.20	7.95	22.0
24.0	7.45	7.30	7.15	7.05	6.90	6.75	24.0
26.0	6.40	6.20	6.05	5.95	5.80	5.65	26.0
28.0	5.45	5.30	5.15	5.00	4.85	4.70	28.0
30.0	4.70	4.50	4.35	4.25	4.05	3.90	30.0
32.0	4.00	3.85	3.70	3.55	3.40	3.25	32.0
34.0	3.40	3.25	3.10	2.95	2.80	2.65	34.0
36.0	2.90	2.75	2.60	2.45	2.25	2.10	36.0
38.0	2.45	2.30	2.10	1.95	1.80	1.65	38.0
40.0	2.25 /39.0	1.90	1.70	1.55	1.60 /39.0		40.0
42.0		1.60 /41.6	1.50 /41.0				42.0

\* For notes about the table above, refer to page 26.

■ Aux. Sheave (Main Boom: 35 t Hook attached)



Unit: ton loads /working radius

Working Radius(m)	Boom Length (m)										Working Radius(m)	
	12	15	18	21	24	27	30	33	36	39		
4.6	12.00											4.6
5.0	12.00	12.00 /5.3										5.0
5.5	12.00	12.00	12.00 /5.8									5.5
6.0	12.00	12.00	12.00	12.00 /6.3	12.00 /6.9							6.0
7.0	12.00	12.00	12.00	12.00	12.00	12.00 /7.4						7.0
8.0	12.00	12.00	12.00	12.00	12.00	12.00	12.00	12.00 /8.5				8.0
9.0	12.00	12.00	12.00	12.00	12.00	12.00	12.00	12.00	12.00 /9.1	12.00 /9.6		9.0
10.0	12.00	12.00	12.00	12.00	12.00	12.00	12.00	12.00	12.00	12.00	12.00	10.0
12.0	12.00	12.00	12.00	12.00	12.00	12.00	12.00	12.00	12.00	12.00	12.00	12.0
14.0	12.00 /13.1	12.00	12.00	12.00	12.00	12.00	12.00	12.00	12.00	12.00	12.00	14.0
16.0		12.00 /15.7	12.00	12.00	12.00	12.00	12.00	12.00	12.00	12.00	12.00	16.0
18.0			12.00	12.00	12.00	12.00	12.00	12.00	12.00	12.00	12.00	18.0
20.0			12.00 /18.2	11.85	11.40	11.20	11.10	11.10	10.90	10.85		20.0
22.0				11.20 /20.8	10.10	9.95	9.75	9.55	9.30	9.25		22.0
24.0					9.20 /23.4	8.70	8.45	8.25	8.00	7.95		24.0
26.0						7.60	7.40	7.20	6.95	6.90		26.0
28.0							6.50	6.30	6.05	5.95		28.0
30.0							6.30 /28.6	5.50	5.25	5.20		30.0
32.0								5.10 /31.2	4.60	4.50		32.0
34.0									4.10 /33.8	3.95		34.0
36.0										3.40		36.0
38.0										3.35 /36.4		38.0

Unit: ton loads /working radius

Working Radius(m)	Boom Length (m)						Working Radius(m)
	42	45	48	51	54	57	
10.0	12.00 /10.2	12.00 /10.7	12.00 /11.3	12.00 /11.8			10.0
12.0	12.00	12.00	12.00	12.00	12.00 /12.4	12.00 /12.9	12.0
14.0	12.00	12.00	12.00	12.00	12.00	12.00	14.0
16.0	12.00	12.00	12.00	12.00	12.00	12.00	16.0
18.0	12.00	12.00	12.00	11.80	11.35	11.10	18.0
20.0	10.65	10.45	10.35	10.20	9.90	9.55	20.0
22.0	9.00	8.85	8.70	8.60	8.45	8.20	22.0
24.0	7.70	7.55	7.40	7.30	7.15	7.00	24.0
26.0	6.65	6.45	6.30	6.20	6.05	5.90	26.0
28.0	5.70	5.55	5.40	5.25	5.10	4.95	28.0
30.0	4.95	4.75	4.60	4.50	4.30	4.15	30.0
32.0	4.25	4.10	3.95	3.80	3.65	3.50	32.0
34.0	3.65	3.50	3.35	3.20	3.05	2.90	34.0
36.0	3.15	3.00	2.85	2.70	2.50	2.35	36.0
38.0	2.70	2.55	2.35	2.20	2.05	1.90	38.0
40.0	2.50 /39.0	2.15	1.95	1.80	1.65	1.45	40.0
42.0		1.85 /41.6	1.60	1.45	1.50 /40.8		42.0
44.0			1.45 /43.0				44.0

\* For notes about the table above, refer to page 26.

■ Aux. Sheave (Main Boom: No Hook attached)



Unit: ton loads /working radius

Working Radius(m)	Boom Length (m)										Working Radius(m)	
	12	15	18	21	24	27	30	33	36	39		
4.6	12.00											4.6
5.0	12.00	12.00 /5.3										5.0
5.5	12.00	12.00	12.00 /5.8									5.5
6.0	12.00	12.00	12.00	12.00 /6.3	12.00 /6.9							6.0
7.0	12.00	12.00	12.00	12.00	12.00	12.00 /7.4						7.0
8.0	12.00	12.00	12.00	12.00	12.00	12.00	12.00	12.00 /8.5				8.0
9.0	12.00	12.00	12.00	12.00	12.00	12.00	12.00	12.00	12.00 /9.1	12.00 /9.6		9.0
10.0	12.00	12.00	12.00	12.00	12.00	12.00	12.00	12.00	12.00	12.00	12.00	10.0
12.0	12.00	12.00	12.00	12.00	12.00	12.00	12.00	12.00	12.00	12.00	12.00	12.0
14.0	12.00 /13.1	12.00	12.00	12.00	12.00	12.00	12.00	12.00	12.00	12.00	12.00	14.0
16.0		12.00 /15.7	12.00	12.00	12.00	12.00	12.00	12.00	12.00	12.00	12.00	16.0
18.0			12.00	12.00	12.00	12.00	12.00	12.00	12.00	12.00	12.00	18.0
20.0			12.00 /18.2	12.00	12.00	12.00	12.00	12.00	12.00	11.80	11.75	20.0
22.0				12.00 /20.8	11.00	10.85	10.65	10.45	10.20	10.15		22.0
24.0					10.10 /23.4	9.60	9.35	9.15	8.90	8.85		24.0
26.0						8.50	8.30	8.10	7.85	7.80		26.0
28.0							7.40	7.20	6.95	6.85		28.0
30.0							7.20 /28.6	6.40	6.15	6.10		30.0
32.0								6.00 /31.2	5.50	5.40		32.0
34.0									5.00 /33.8	4.85		34.0
36.0										4.30		36.0
38.0										4.25 /36.4		38.0

Unit: ton loads /working radius

Working Radius(m)	Boom Length (m)						Working Radius(m)
	42	45	48	51	54	57	
10.0	12.00 /10.2	12.00 /10.7	12.00 /11.3	12.00 /11.8			10.0
12.0	12.00	12.00	12.00	12.00	12.00 /12.4	12.00 /12.9	12.0
14.0	12.00	12.00	12.00	12.00	12.00	12.00	14.0
16.0	12.00	12.00	12.00	12.00	12.00	12.00	16.0
18.0	12.00	12.00	12.00	12.00	12.00	12.00	18.0
20.0	11.55	11.35	11.25	11.10	10.80	10.45	20.0
22.0	9.90	9.75	9.60	9.50	9.35	9.10	22.0
24.0	8.60	8.45	8.30	8.20	8.05	7.90	24.0
26.0	7.55	7.35	7.20	7.10	6.95	6.80	26.0
28.0	6.60	6.45	6.30	6.15	6.00	5.85	28.0
30.0	5.85	5.65	5.50	5.40	5.20	5.05	30.0
32.0	5.15	5.00	4.85	4.70	4.55	4.40	32.0
34.0	4.55	4.40	4.25	4.10	3.95	3.80	34.0
36.0	4.05	3.90	3.75	3.60	3.40	3.25	36.0
38.0	3.60	3.45	3.25	3.10	2.95	2.80	38.0
40.0	3.40 /39.0	3.05	2.85	2.70	2.55	2.35	40.0
42.0		2.75 /41.6	2.50	2.35	2.20 /41.7	2.20 /40.8	42.0
44.0			2.20	2.20 /42.8			44.0

\* For notes about the table above, refer to page 26.

■ Main Boom with Aux. Sheave



Unit: ton loads /working radius

Working Radius(m)	Boom Length (m)										Working Radius(m)
	12	15	18	21	24	27	30	33	36	39	
3.8	97.60										3.8
4.0	94.95										4.0
4.5	84.40	84.40									4.5
5.0	75.95	75.95	75.95								5.0
5.5	69.05	69.05	68.80	65.10 /5.6							5.5
6.0	63.30	63.30	62.80	60.20	56.60 /6.1	49.20 /6.7					6.0
7.0	54.10	54.10	52.40	50.50	48.70	47.00	44.00 /7.2	39.00 /7.8			7.0
8.0	44.50	44.40	44.30	43.50	42.00	40.70	39.40	38.00	35.40 /8.3	32.30 /8.8	8.0
9.0	37.70	37.60	37.50	37.40	36.80	35.70	34.70	33.50	32.50	31.60	9.0
10.0	32.60	32.50	32.30	32.30	32.10	31.80	30.90	29.90	29.00	28.20	10.0
12.0	26.10 /11.8	25.40	25.20	25.10	25.00	24.90	24.70	24.50	23.80	23.20	12.0
14.0		20.70	20.50	20.40	20.20	20.10	19.90	19.80	19.50	19.40	14.0
16.0		19.90 /14.4	17.10	17.00	16.80	16.70	16.50	16.40	16.10	16.10	16.0
18.0			15.80 /17.0	14.50	14.30	14.20	14.00	13.80	13.60	13.50	18.0
20.0				12.90 /19.6	12.40	12.30	12.00	11.80	11.60	11.60	20.0
22.0					10.80	10.70	10.50	10.30	10.00	10.00	22.0
24.0					10.70 /22.2	9.40	9.20	9.00	8.70	8.70	24.0
26.0						9.00 /24.8	8.20	7.90	7.70	7.60	26.0
28.0							7.50 /27.4	7.00	6.80	6.70	28.0
30.0								6.30	6.00	5.90	30.0
32.0									5.40	5.30	32.0
34.0									5.20 /32.6	4.70	34.0
36.0										4.40 /35.2	36.0

Unit: ton loads /working radius

Working Radius(m)	Boom Length (m)						Working Radius(m)
	42	45	48	51	54	57	
9.0	29.20 /9.4	26.90 /9.9					9.0
10.0	27.40	26.70	24.70 /10.5	21.40 /11.1	18.30 /11.6		10.0
12.0	22.50	21.90	21.40	20.70	18.10	17.00 /12.2	12.0
14.0	18.90	18.40	17.90	17.30	16.90	16.30	14.0
16.0	15.80	15.70	15.30	14.80	14.40	14.00	16.0
18.0	13.30	13.10	13.00	12.70	12.40	12.00	18.0
20.0	11.30	11.10	11.00	10.90	10.70	10.40	20.0
22.0	9.70	9.60	9.40	9.30	9.10	9.00	22.0
24.0	8.40	8.30	8.10	8.00	7.80	7.70	24.0
26.0	7.40	7.20	7.00	6.90	6.70	6.60	26.0
28.0	6.50	6.30	6.10	6.00	5.80	5.70	28.0
30.0	5.70	5.50	5.40	5.20	5.00	4.90	30.0
32.0	5.00	4.80	4.70	4.50	4.40	4.20	32.0
34.0	4.40	4.30	4.10	3.90	3.80	3.60	34.0
36.0	3.90	3.80	3.60	3.40	3.20	3.10	36.0
38.0	3.50 /37.8	3.30	3.20	3.00	2.80	2.60	38.0
40.0		2.90	2.80	2.50	2.40	2.20	40.0
42.0		2.90 /40.4	2.40	2.20	2.20 /41.0		42.0
43.0			2.20				43.0

1. The rated loads are determined according to EN13000 rating on the condition that the machine is stationed on firm, level ground.
2. The figures surrounded by bold lines are based on factors other than those which would cause a tipping condition.
3. To calculate the maximum load that can actually be lifted, deduct weight of all lifting accessories, such as boom hook and jib hook, from figures shown above.
4. Working radius is the horizontal distance from the slewing center to the center of gravity of a lifted load.
5. The counter weight is 49.5 tons. (Upper weight 37.5 tons + Lower weight 12.0 tons)
6. Correlation between the number of reeved lines, maximum rated loads, hook weights are shown in the table below.

Hook Capacity (t)	Hook Weight (t)	Maximum Rated Loads (t)							
		8 falls	7 falls	6 falls	5 falls	4 falls	3 falls	2 falls	1 fall
100	1.20	100	84	72	60	48	-	-	-
50	1.17	-	-	-	50	48	36	24	-
35	0.90	-	-	-	-	-	35	24	-
12	0.51	-	-	-	-	-	-	-	12

7. When performing repetitive work using buckets, lifting magnets, etc., the higher the load factor, the shorter the life of the structure (boom, frame, winch, etc.).
8. If the value is less than 1.4 tons after deduction of jib hook weight from the rated load shown above, operation is not available.

■ Crane Jib



Unit: ton [loads/working radius]

Boom Length (m)	24.0								Boom Length (m)
Jib Length (m)	10.0		16.0		22.0		28.0		Jib Length (m)
Offset Angle (deg) Radius (m)	10.0	30.0	10.0	30.0	10.0	30.0	10.0	30.0	Offset Angle (deg) Radius (m)
9.5	12.00								9.5
10.0	12.00		12.00 /11.6						10.0
12.0	12.00	11.25 /12.5	12.00		8.80 /13.7				12.0
14.0	12.00	10.75	12.00		8.80		5.50 /15.8		14.0
16.0	12.00	10.10	12.00	8.00 /16.4	8.80		5.50		16.0
18.0	12.00	9.60	12.00	7.60	8.80		5.50		18.0
20.0	12.00	9.15	12.00	7.20	8.80	6.00 /20.3	5.50		20.0
22.0	11.45	8.75	11.75	6.85	8.80	5.75	5.50		22.0
24.0	10.15	8.40	10.40	6.50	8.45	5.45	5.50	3.40 /24.2	24.0
26.0	9.05	8.10	9.30	6.25	8.15	5.20	5.50	3.40	26.0
28.0	8.10	7.85	8.35	6.00	7.80	4.95	5.45	3.40	28.0
30.0	7.35	7.45	7.60	5.75	7.50	4.75	5.20	3.40	30.0
32.0	6.70 /31.9	6.70	6.90	5.55	7.05	4.55	5.00	3.40	32.0
34.0		6.55 /32.5	6.30	5.40	6.45	4.35	4.80	3.40	34.0
36.0			5.75	5.30	5.90	4.20	4.65	3.40	36.0
38.0			5.40 /37.6	5.20	5.45	4.10	4.40	3.40	38.0
40.0				5.20 /38.5	5.00	4.00	4.25	3.30	40.0
42.0					4.65	3.90	4.15	3.20	42.0
44.0					4.45 /43.2	3.85	4.00	3.10	44.0
46.0						3.85 /44.5	3.85	3.00	46.0
48.0							3.75	2.95	48.0
50.0							3.65 /48.9	2.90	50.0
52.0							2.90 /50.5		52.0

Unit: ton [loads/working radius]

Boom Length (m)	27.0								Boom Length (m)
Jib Length (m)	10.0		16.0		22.0		28.0		Jib Length (m)
Offset Angle (deg) Radius (m)	10.0	30.0	10.0	30.0	10.0	30.0	10.0	30.0	Offset Angle (deg) Radius (m)
10.0	12.00								10.0
12.0	12.00	11.25 /13.0	12.00 /12.1						12.0
14.0	12.00	10.90	12.00		8.80 /14.2				14.0
16.0	12.00	10.35	12.00	7.95 /16.9	8.80		5.50 /16.3		16.0
18.0	12.00	9.80	12.00	7.75	8.80		5.50		18.0
20.0	12.00	9.35	12.00	7.35	8.80	6.00 /20.8	5.50		20.0
22.0	11.30	8.95	11.60	7.00	8.80	5.85	5.50		22.0
24.0	10.00	8.60	10.25	6.65	8.65	5.55	5.50	3.40 /24.7	24.0
26.0	8.90	8.30	9.15	6.40	8.30	5.30	5.50	3.40	26.0
28.0	7.95	8.05	8.25	6.15	8.00	5.05	5.50	3.40	28.0
30.0	7.20	7.30	7.45	5.90	7.60	4.85	5.40	3.40	30.0
32.0	6.50	6.60	6.75	5.70	6.90	4.65	5.15	3.40	32.0
34.0	5.90	5.95	6.15	5.55	6.30	4.50	4.95	3.40	34.0
36.0	5.75 /34.5	5.65 /35.1	5.60	5.40	5.75	4.35	4.75	3.40	36.0
38.0			5.15	5.25	5.30	4.20	4.55	3.40	38.0
40.0			4.70	4.80	4.85	4.10	4.45	3.40	40.0
42.0			4.70 /40.2	4.55 /41.1	4.45	4.00	4.25	3.25	42.0
44.0					4.15	3.90	4.10	3.15	44.0
46.0					3.85 /45.8	3.85	3.90	3.10	46.0
48.0						3.75 /47.1	3.60	3.00	48.0
50.0							3.35	2.95	50.0
52.0							3.20 /51.5	2.90	52.0
54.0							2.90 /53.1		54.0

- The rated loads are determined according to EN13000 rating on the condition that the machine is stationed on firm, level ground.
- The figures surrounded by bold lines are based on factors other than those which would cause a tipping condition.
- To calculate the maximum load that can actually be lifted, deduct weight of all lifting accessories, such as boom hook and jib hook, from figures shown above.
- Working radius is the horizontal distance from the slewing center to the center of gravity of a lifted load.
- The offset angles shown are of jib boom offset angle against the main boom, under load.
- The counter weight is 49.5 tons. (Upper weight 37.5 tons + Lower weight 12.0 tons)
- Hook weight are shown in the table below.

Hook Capacity (t)	Hook Weight (t)
100	1.20
50	1.17
35	0.90
12	0.51

- If the value is less than 1.4 tons after deduction of boom hook weight from the rated load shown above, operation is not available.

■ Crane Jib



Unit: ton loads/working radius

Boom Length (m)	30								Boom Length (m)
Jib Length (m)	10		16		22		28		Jib Length (m)
Offset Angle (deg) Radius (m)	10	30	10	30	10	30	10	30	Offset Angle (deg) Radius (m)
10.0	12.00 /10.6								10.0
12.0	12.00	11.20 /13.6	12.00 /12.7						12.0
14.0	12.00	11.05	12.00		8.80 /14.8				14.0
16.0	12.00	10.50	12.00	7.95 /17.5	8.80		5.50 /16.9		16.0
18.0	12.00	10.00	12.00	7.85	8.80		5.50		18.0
20.0	12.00	9.55	12.00	7.45	8.80	6.00 /21.4	5.50		20.0
22.0	11.10	9.20	11.40	7.10	8.80	5.90	5.50		22.0
24.0	9.75	8.85	10.05	6.80	8.75	5.60	5.50	3.40 /25.3	24.0
26.0	8.65	8.55	8.95	6.55	8.45	5.35	5.50	3.40	26.0
28.0	7.75	7.95	8.00	6.30	8.20	5.15	5.50	3.40	28.0
30.0	6.95	7.15	7.20	6.05	7.40	4.95	5.50	3.40	30.0
32.0	6.30	6.40	6.50	5.85	6.70	4.75	5.35	3.40	32.0
34.0	5.70	5.80	5.90	5.70	6.10	4.60	5.10	3.40	34.0
36.0	5.15	5.25	5.40	5.55	5.55	4.45	4.90	3.40	36.0
38.0	4.90 /37.1	4.80 /37.7	4.90	5.10	5.10	4.30	4.70	3.40	38.0
40.0			4.50	4.65	4.65	4.15	4.55	3.40	40.0
42.0			4.15	4.20	4.25	4.05	4.40	3.35	42.0
44.0			4.00 /42.8	3.90 /43.7	3.95	3.95	4.05	3.25	44.0
46.0					3.60	3.75	3.70	3.15	46.0
48.0					3.35	3.45	3.40	3.05	48.0
50.0					3.30 /48.4	3.20 /49.7	3.15	3.00	50.0
52.0							2.90	2.95	52.0
54.0							2.70	2.80	54.0
56.0							2.70 /54.1	2.60 /55.7	56.0

Unit: ton loads/working radius

Boom Length (m)	33								Boom Length (m)
Jib Length (m)	10		16		22		28		Jib Length (m)
Offset Angle (deg) Radius (m)	10	30	10	30	10	30	10	30	Offset Angle (deg) Radius (m)
10.0	12.00 /11.1								10.0
12.0	12.00		12.00 /13.2						12.0
14.0	12.00	11.20 /14.1	12.00		8.80 /15.3				14.0
16.0	12.00	10.65	12.00		8.80		5.50 /17.4		16.0
18.0	12.00	10.20	12.00	7.95	8.80		5.50		18.0
20.0	12.00	9.75	12.00	7.55	8.80	6.00 /21.9	5.50		20.0
22.0	10.90	9.40	11.25	7.25	8.80	5.95	5.50		22.0
24.0	9.60	9.05	9.90	6.95	8.80	5.70	5.50	3.40 /25.8	24.0
26.0	8.50	8.75	8.75	6.65	8.65	5.45	5.50	3.40	26.0
28.0	7.55	7.80	7.85	6.40	8.05	5.25	5.50	3.40	28.0
30.0	6.75	6.95	7.05	6.20	7.25	5.05	5.50	3.40	30.0
32.0	6.05	6.25	6.35	6.00	6.55	4.85	5.40	3.40	32.0
34.0	5.45	5.60	5.70	5.80	5.90	4.70	5.20	3.40	34.0
36.0	4.95	5.05	5.20	5.45	5.35	4.55	5.05	3.40	36.0
38.0	4.50	4.55	4.70	4.90	4.90	4.40	4.85	3.40	38.0
40.0	4.10 /39.7	4.10	4.30	4.45	4.45	4.25	4.60	3.40	40.0
42.0		4.05 /40.3	3.90	4.05	4.05	4.15	4.20	3.40	42.0
44.0			3.55	3.65	3.70	3.95	3.85	3.30	44.0
46.0			3.35 /45.4	3.30	3.40	3.60	3.50	3.20	46.0
48.0				3.25 /46.3	3.10	3.30	3.25	3.15	48.0
50.0					2.85	3.00	2.95	3.05	50.0
52.0					2.75 /51.0	2.70	2.70	2.95	52.0
54.0						2.65 /52.3	2.50	2.65	54.0
56.0							2.30	2.40	56.0
58.0							2.25 /56.7	2.20	58.0

\* For notes about the table above, refer to page 31.



■ Crane Jib



Unit: ton loads/working radius

Boom Length (m)	36								Boom Length (m)
Jib Length (m)	10		16		22		28		Jib Length (m)
Offset Angle (deg) Radius (m)	10	30	10	30	10	30	10	30	Offset Angle (deg) Radius (m)
11.7	12.00								11.7
12.0	12.00		12.00 /13.8						12.0
14.0	12.00	11.15 /14.7	12.00		8.80 /15.9				14.0
16.0	12.00	10.80	12.00		8.80				16.0
18.0	12.00	10.35	12.00	7.90 /18.6	8.80		5.50		18.0
20.0	12.00	9.95	12.00	7.65	8.80		5.50		20.0
22.0	10.65	9.55	11.00	7.35	8.80	5.95 /22.5	5.50		22.0
24.0	9.35	9.20	9.65	7.05	8.80	5.75	5.50		24.0
26.0	8.25	8.55	8.55	6.80	8.80	5.55	5.50	3.40 /26.4	26.0
28.0	7.30	7.60	7.60	6.55	7.85	5.30	5.50	3.40	28.0
30.0	6.50	6.75	6.80	6.30	7.00	5.10	5.50	3.40	30.0
32.0	5.80	6.00	6.10	6.10	6.30	4.95	5.50	3.40	32.0
34.0	5.20	5.40	5.50	5.80	5.70	4.75	5.35	3.40	34.0
36.0	4.70	4.85	4.95	5.25	5.15	4.60	5.15	3.40	36.0
38.0	4.20	4.35	4.45	4.75	4.65	4.50	4.80	3.40	38.0
40.0	3.80	3.90	4.05	4.25	4.25	4.35	4.35	3.40	40.0
42.0	3.45	3.50	3.65	3.85	3.85	4.15	4.00	3.40	42.0
44.0	3.40 /42.3	3.35 /42.9	3.30	3.45	3.50	3.75	3.65	3.35	44.0
46.0			3.00	3.15	3.20	3.40	3.30	3.30	46.0
48.0			2.70	2.80	2.90	3.10	3.00	3.20	48.0
50.0				2.70 /48.9	2.65	2.80	2.75	3.05	50.0
52.0					2.40	2.50	2.50	2.75	52.0
54.0					2.20 /53.6	2.25	2.30	2.50	54.0
56.0						2.20 /54.4	2.20 /54.8	2.25	56.0
56.4							2.20	2.20	56.4

Unit: ton loads/working radius

Boom Length (m)	39								Boom Length (m)
Jib Length (m)	10		16		22		28		Jib Length (m)
Offset Angle (deg) Radius (m)	10	30	10	30	10	30	10	30	Offset Angle (deg) Radius (m)
12.0	12.00 /12.2								12.0
14.0	12.00	11.15 /15.2	12.00 /14.3						14.0
16.0	12.00	10.95	12.00		8.80 /16.4				16.0
18.0	12.00	10.50	12.00	7.90 /19.1	8.80		5.50 /18.5		18.0
20.0	12.00	10.10	12.00	7.75	8.80		5.50		20.0
22.0	10.60	9.70	10.90	7.45	8.80	5.95 /23.0	5.50		22.0
24.0	9.25	9.40	9.60	7.15	8.80	5.85	5.50		24.0
26.0	8.15	8.50	8.45	6.90	8.70	5.60	5.50	3.40 /26.9	26.0
28.0	7.20	7.50	7.50	6.65	7.75	5.40	5.50	3.40	28.0
30.0	6.40	6.70	6.70	6.45	6.90	5.20	5.50	3.40	30.0
32.0	5.70	5.95	6.00	6.25	6.20	5.00	5.50	3.40	32.0
34.0	5.10	5.30	5.40	5.75	5.60	4.85	5.50	3.40	34.0
36.0	4.60	4.75	4.85	5.15	5.05	4.70	5.20	3.40	36.0
38.0	4.10	4.25	4.35	4.65	4.55	4.55	4.70	3.40	38.0
40.0	3.70	3.80	3.95	4.20	4.10	4.45	4.25	3.40	40.0
42.0	3.30	3.40	3.55	3.75	3.75	4.10	3.85	3.40	42.0
44.0	3.00	3.05	3.20	3.40	3.40	3.70	3.50	3.40	44.0
46.0	2.85 /44.9	2.80 /45.5	2.90	3.05	3.05	3.35	3.20	3.35	46.0
48.0			2.60	2.75	2.75	3.00	2.90	3.25	48.0
50.0			2.35	2.45	2.50	2.70	2.65	2.95	50.0
52.0			2.30 /50.6	2.25 /51.5	2.25	2.45	2.40	2.65	52.0
54.0					2.20 /52.5	2.20	2.20 /53.6	2.40	54.0
56.0							2.20 /55.6	2.20	56.0

\* For notes about the table above, refer to page 31.

■ Crane Jib



Unit: ton [loads/working radius]

Boom Length (m)	42								Boom Length (m)
Jib Length (m)	10		16		22		28		Jib Length (m)
Offset Angle (deg) Radius (m)	10	30	10	30	10	30	10	30	Offset Angle (deg) Radius (m)
12.0	12.00 /12.8								12.0
14.0	12.00	11.10 /15.8	12.00 /14.9						14.0
16.0	12.00	11.05	12.00		8.80 /17.0				16.0
18.0	12.00	10.60	12.00	7.85 /19.7	8.80		5.50 /19.1		18.0
20.0	12.00	10.25	12.00	7.85	8.80		5.50		20.0
22.0	10.35	9.85	10.70	7.50	8.80	5.95 /23.6	5.50		22.0
24.0	9.00	9.45	9.35	7.25	8.80	5.90	5.50		24.0
26.0	7.90	8.30	8.25	7.00	8.50	5.65	5.50	3.40 /27.5	26.0
28.0	6.95	7.30	7.30	6.75	7.55	5.45	5.50	3.40	28.0
30.0	6.15	6.45	6.45	6.55	6.70	5.25	5.50	3.40	30.0
32.0	5.50	5.75	5.75	6.20	6.00	5.10	5.50	3.40	32.0
34.0	4.85	5.10	5.15	5.55	5.35	4.90	5.50	3.40	34.0
36.0	4.35	4.55	4.60	5.00	4.80	4.75	5.00	3.40	36.0
38.0	3.85	4.05	4.15	4.45	4.35	4.65	4.50	3.40	38.0
40.0	3.45	3.60	3.70	4.00	3.90	4.35	4.05	3.40	40.0
42.0	3.05	3.20	3.30	3.55	3.50	3.90	3.65	3.40	42.0
44.0	2.75	2.80	2.95	3.20	3.15	3.50	3.30	3.40	44.0
46.0	2.45	2.50	2.65	2.85	2.85	3.15	3.00	3.40	46.0
48.0	2.20 /47.5	2.20	2.35	2.50	2.55	2.85	2.70	3.10	48.0
50.0		2.20 /48.1	2.20 /49.2	2.25	2.30	2.50	2.40	2.80	50.0
52.0				2.20 /50.3	2.20 /50.8	2.25	2.20 /51.6	2.50	52.0
54.0						2.20 /52.4		2.25	54.0
54.4								2.20	54.4

Unit: ton [loads/working radius]

Boom Length (m)	45								Boom Length (m)
Jib Length (m)	10		16		22		28		Jib Length (m)
Offset Angle (deg) Radius (m)	10	30	10	30	10	30	10	30	Offset Angle (deg) Radius (m)
12.0	12.00 /13.3								12.0
14.0	12.00		12.00 /15.4						14.0
16.0	12.00	11.10 /16.3	12.00		8.80 /17.5				16.0
18.0	12.00	10.75	12.00		8.80		5.50 /19.6		18.0
20.0	11.85	10.35	12.00	7.85 /20.2	8.80		5.50		20.0
22.0	10.20	10.00	10.55	7.60	8.80		5.50		22.0
24.0	8.85	9.35	9.20	7.35	8.80	5.95 /24.1	5.50		24.0
26.0	7.75	8.15	8.10	7.10	8.35	5.70	5.50		26.0
28.0	6.80	7.15	7.10	6.85	7.40	5.50	5.50	3.40	28.0
30.0	6.00	6.35	6.30	6.65	6.55	5.35	5.50	3.40	30.0
32.0	5.30	5.60	5.60	6.10	5.85	5.15	5.50	3.40	32.0
34.0	4.70	4.95	5.00	5.45	5.20	5.00	5.40	3.40	34.0
36.0	4.15	4.40	4.45	4.85	4.65	4.85	4.85	3.40	36.0
38.0	3.70	3.90	3.95	4.30	4.15	4.70	4.35	3.40	38.0
40.0	3.25	3.45	3.55	3.85	3.75	4.20	3.90	3.40	40.0
42.0	2.90	3.05	3.15	3.40	3.35	3.75	3.50	3.40	42.0
44.0	2.55	2.65	2.80	3.05	3.00	3.40	3.15	3.40	44.0
46.0	2.25	2.35	2.50	2.70	2.65	3.00	2.80	3.30	46.0
48.0	2.20 /46.3	2.20 /47.0	2.20	2.40	2.35	2.70	2.50	2.95	48.0
50.0				2.20 /49.3	2.20 /49.2	2.40	2.25	2.65	50.0
52.0						2.20 /51.3	2.20 /50.4	2.35	52.0
54.0								2.20 /53.2	54.0

\* For notes about the table above, refer to page 31.

■ Crane Jib



Unit: ton loads /working radius

48									
Boom Length (m)	48								Boom Length (m)
Jib Length (m)	10		16		22		28		Jib Length (m)
Offset Angle (deg)	10	30	10	30	10	30	10	30	Offset Angle (deg)
Radius (m)									Radius (m)
13.9	12.00								13.9
14.0	12.00								14.0
16.0	12.00	11.05 /16.9	12.00						16.0
18.0	12.00	10.85	12.00		8.80 /18.1				18.0
20.0	11.70	10.45	12.00	7.85 /20.8	8.80		5.50 /20.2		20.0
22.0	10.05	10.15	10.40	7.70	8.80		5.50		22.0
24.0	8.70	9.20	9.05	7.40	8.80	5.90 /24.6	5.50		24.0
26.0	7.60	8.05	7.90	7.15	8.20	5.75	5.50		26.0
28.0	6.65	7.05	6.95	6.95	7.25	5.55	5.50	3.40 /28.5	28.0
30.0	5.85	6.20	6.15	6.75	6.40	5.40	5.50	3.40	30.0
32.0	5.15	5.45	5.45	5.95	5.70	5.20	5.50	3.40	32.0
34.0	4.55	4.80	4.80	5.30	5.05	5.05	5.25	3.40	34.0
36.0	4.00	4.25	4.30	4.70	4.50	4.90	4.70	3.40	36.0
38.0	3.55	3.75	3.80	4.20	4.00	4.55	4.20	3.40	38.0
40.0	3.10	3.30	3.35	3.70	3.55	4.10	3.75	3.40	40.0
42.0	2.70	2.90	3.00	3.30	3.20	3.65	3.35	3.40	42.0
44.0	2.40	2.50	2.65	2.90	2.80	3.25	3.00	3.40	44.0
46.0	2.20 /45.3	2.20	2.30	2.55	2.50	2.90	2.65	3.20	46.0
48.0			2.20 /46.6	2.25	2.20	2.55	2.35	2.85	48.0
50.0				2.20 /48.3		2.25	2.20 /49.2	2.55	50.0
52.0						2.20 /50.4		2.25	52.0
52.3								2.20	52.3

Unit: ton loads /working radius

51									
Boom Length (m)	51								Boom Length (m)
Jib Length (m)	10		16		22		28		Jib Length (m)
Offset Angle (deg)	10	30	10	30	10	30	10	30	Offset Angle (deg)
Radius (m)									Radius (m)
14.0	12.00 /14.4								14.0
16.0	12.00	11.05 /17.4	12.00 /16.5						16.0
18.0	12.00	10.95	12.00		8.80 /18.6				18.0
20.0	11.40	10.60	11.75	7.85 /21.3	8.80		5.50 /20.7		20.0
22.0	9.90	10.25	10.30	7.75	8.80		5.50		22.0
24.0	8.60	9.10	8.95	7.50	8.80	5.90 /25.2	5.50		24.0
26.0	7.45	7.95	7.80	7.25	8.05	5.80	5.50		26.0
28.0	6.50	6.95	6.85	7.00	7.10	5.65	5.50	3.40 /29.1	28.0
30.0	5.70	6.10	6.00	6.65	6.25	5.45	5.50	3.40	30.0
32.0	5.00	5.35	5.30	5.85	5.55	5.30	5.50	3.40	32.0
34.0	4.40	4.70	4.70	5.20	4.90	5.10	5.10	3.40	34.0
36.0	3.85	4.10	4.15	4.60	4.35	5.00	4.55	3.40	36.0
38.0	3.35	3.60	3.65	4.05	3.85	4.45	4.05	3.40	38.0
40.0	2.95	3.15	3.20	3.60	3.45	4.00	3.60	3.40	40.0
42.0	2.55	2.75	2.85	3.15	3.05	3.55	3.20	3.40	42.0
44.0	2.20	2.40	2.45	2.80	2.70	3.15	2.85	3.40	44.0
46.0		2.20 /45.1	2.20 /45.6	2.45	2.35	2.75	2.50	3.05	46.0
48.0				2.20 /47.4	2.20 /47.0	2.45	2.20	2.75	48.0
50.0						2.20 /49.6		2.40	50.0
52.0								2.20 /51.6	52.0

\* For notes about the table above, refer to page 31.

■ Main Boom with Crane Jib



Unit: ton loads /working radius

Boom Length (m)	24								Boom Length (m)
Jib Length (m)	10		16		22		28		Jib Length (m)
Offset Angle (deg)	10	30	10	30	10	30	10	30	Offset Angle (deg)
Radius (m)									
6.0	50.00 /6.1	50.00 /6.1	50.00 /6.1	50.00 /6.1	50.00 /6.1	50.00 /6.1	50.00 /6.1	50.00 /6.1	6.0
7.0	47.80	47.45	47.10	46.50	46.30	45.35	45.40	44.05	7.0
8.0	41.10	40.80	40.45	39.90	39.65	38.85	38.80	37.65	8.0
9.0	35.95	35.70	35.30	34.85	34.55	33.85	33.70	32.70	9.0
10.0	31.35	31.10	30.80	30.35	30.15	29.50	29.40	28.50	10.0
12.0	24.15	24.00	23.65	23.35	23.00	22.55	22.30	21.65	12.0
14.0	19.40	19.30	18.90	18.65	18.30	17.95	17.65	17.15	14.0
16.0	16.05	15.95	15.50	15.35	14.95	14.70	14.30	13.95	16.0
18.0	13.50	13.45	13.00	12.90	12.45	12.30	11.85	11.60	18.0
20.0	11.55	11.50	11.10	11.00	10.55	10.40	9.95	9.80	20.0
22.0	10.00	10.00	9.55	9.50	9.05	9.00	8.45	8.40	22.0
24.0	9.90 /22.2	9.85 /22.2	9.40 /22.2	9.40 /22.2	8.90 /22.2	8.85 /22.2	8.30 /22.2	8.25 /22.2	24.0

Unit: ton loads /working radius

Boom Length (m)	27								Boom Length (m)
Jib Length (m)	10		16		22		28		Jib Length (m)
Offset Angle (deg)	10	30	10	30	10	30	10	30	Offset Angle (deg)
Radius (m)									
6.0	48.35 /6.7	48.00 /6.7	47.70 /6.7	47.05 /6.7	46.95 /6.7	45.95 /6.7	46.10 /6.7	44.65 /6.7	6.0
7.0	46.10	45.75	45.45	44.85	44.70	43.75	43.85	42.50	7.0
8.0	39.75	39.50	39.15	38.60	38.40	37.60	37.60	36.45	8.0
9.0	34.85	34.60	34.25	33.80	33.55	32.85	32.75	31.75	9.0
10.0	30.95	30.70	30.35	29.95	29.65	29.05	28.85	28.00	10.0
12.0	24.10	23.95	23.60	23.30	23.00	22.50	22.35	21.65	12.0
14.0	19.35	19.20	18.85	18.60	18.30	17.90	17.65	17.10	14.0
16.0	15.95	15.85	15.45	15.30	14.90	14.65	14.30	13.90	16.0
18.0	13.40	13.35	12.95	12.80	12.40	12.20	11.80	11.50	18.0
20.0	11.45	11.40	11.00	10.90	10.50	10.30	9.90	9.70	20.0
22.0	9.90	9.85	9.45	9.35	8.95	8.85	8.40	8.25	22.0
24.0	8.65	8.60	8.20	8.15	7.70	7.65	7.15	7.10	24.0
26.0	8.20 /24.8	8.15 /24.8	7.75 /24.8	7.75 /24.8	7.30 /24.8	7.25 /24.8	6.75 /24.8	6.70 /24.8	26.0

- The rated loads are determined according to EN13000 rating on the condition that the machine is stationed on firm, level ground.
- The figures surrounded by bold lines are based on factors other than those which would cause a tipping condition.
- To calculate the maximum load that can actually be lifted, deduct weight of all lifting accessories, such as boom hook and jib hook, from figures shown above.
- Working radius is the horizontal distance from the slewing center to the center of gravity of a lifted load.
- The offset angles shown are of jib boom offset angle against the main boom, under load.
- The counter weight is 49.5 tons. (Upper weight 37.5 tons + Lower weight 12.0 tons)
- Correlation between the number of reeved lines, maximum rated loads, hook weights are shown in the table below.

Hook Capacity (t)	Hook Weight (t)	Maximum Rated Loads (t)				
		5 falls	4 falls	3 falls	2 falls	1 fall
100	1.20	60	48	-	-	-
50	1.17	50	48	36	24	-
35	0.90	-	-	35	24	-
12	0.51	-	-	-	-	12

- When performing repetitive work using buckets, lifting magnets, etc., the higher the load factor, the shorter the life of the structure (boom, frame, winch, etc.).
- If the value is less than 1.4 tons after deduction of jib hook weight from the rated load shown above, operation is not available.

■ Main Boom with Crane Jib



Unit: ton loads /working radius

Boom Length (m)	30								Boom Length (m)
Jib Length (m)	10		16		22		28		Jib Length (m)
Offset Angle (deg) Radius (m)	10	30	10	30	10	30	10	30	Offset Angle (deg) Radius (m)
	7.0	43.15 /7.2	42.85 /7.2	42.55 /7.2	41.95 /7.2	41.85 /7.2	40.90 /7.2	41.00 /7.2	
8.0	38.50	38.20	37.90	37.35	37.20	36.40	36.40	35.25	8.0
9.0	33.80	33.55	33.20	32.75	32.55	31.85	31.80	30.80	9.0
10.0	30.05	29.80	29.45	29.05	28.80	28.20	28.05	27.20	10.0
12.0	23.95	23.75	23.45	23.10	22.90	22.35	22.25	21.50	12.0
14.0	19.15	19.00	18.70	18.40	18.15	17.75	17.55	16.95	14.0
16.0	15.75	15.65	15.30	15.10	14.75	14.45	14.20	13.75	16.0
18.0	13.25	13.15	12.80	12.60	12.25	12.00	11.70	11.35	18.0
20.0	11.25	11.20	10.80	10.70	10.30	10.10	9.75	9.50	20.0
22.0	9.70	9.65	9.25	9.15	8.75	8.65	8.25	8.05	22.0
24.0	8.45	8.40	8.00	7.95	7.50	7.40	7.00	6.85	24.0
26.0	7.40	7.35	6.95	6.90	6.50	6.45	6.00	5.90	26.0
28.0	6.75 /27.4	6.75 /27.4	6.35 /27.4	6.30 /27.4	5.90 /27.4	5.85 /27.4	5.40 /27.4	5.35 /27.4	28.0

Unit: ton loads /working radius

Boom Length (m)	33								Boom Length (m)
Jib Length (m)	10		16		22		28		Jib Length (m)
Offset Angle (deg) Radius (m)	10	30	10	30	10	30	10	30	Offset Angle (deg) Radius (m)
	7.0	38.20 /7.8	37.90 /7.8	37.60 /7.8	37.05 /7.8	36.95 /7.8	36.10 /7.8	36.20 /7.8	
8.0	37.20	36.90	36.60	36.05	35.90	35.10	35.15	34.00	8.0
9.0	32.70	32.45	32.15	31.65	31.50	30.75	30.75	29.75	9.0
10.0	29.10	28.85	28.55	28.10	27.90	27.25	27.20	26.30	10.0
12.0	23.60	23.45	23.10	22.75	22.45	21.95	21.80	21.10	12.0
14.0	19.00	18.85	18.55	18.25	18.00	17.60	17.45	16.85	14.0
16.0	15.60	15.50	15.15	14.95	14.65	14.30	14.05	13.60	16.0
18.0	13.05	12.95	12.60	12.45	12.10	11.85	11.55	11.20	18.0
20.0	11.10	11.00	10.65	10.50	10.15	9.95	9.65	9.30	20.0
22.0	9.50	9.45	9.10	8.95	8.60	8.45	8.10	7.85	22.0
24.0	8.25	8.20	7.80	7.70	7.35	7.20	6.85	6.65	24.0
26.0	7.20	7.15	6.75	6.70	6.30	6.20	5.80	5.65	26.0
28.0	6.30	6.25	5.90	5.85	5.45	5.35	4.95	4.85	28.0
30.0	5.50	5.50	5.10	5.10	4.70	4.60	4.20	4.20	30.0

\* For notes about the table above, refer to page 36.

■ Main Boom with Crane Jib



Unit: ton loads /working radius

Boom Length (m)	36								Boom Length (m)
Jib Length (m)	10		16		22		28		Jib Length (m)
Offset Angle (deg) Radius (m)	10	30	10	30	10	30	10	30	Offset Angle (deg) Radius (m)
8.0	34.55 /8.3	34.30 /8.3	34.00 /8.3	33.50 /8.3	33.35 /8.3	32.60 /8.3	32.65 /8.3	31.55 /8.3	8.0
9.0	31.70	31.40	31.10	30.65	30.50	29.80	29.80	28.80	9.0
10.0	28.20	28.00	27.65	27.25	27.05	26.40	26.35	25.45	10.0
12.0	22.90	22.75	22.40	22.05	21.80	21.30	21.15	20.45	12.0
14.0	18.80	18.65	18.35	18.05	17.80	17.40	17.25	16.60	14.0
16.0	15.40	15.25	14.95	14.70	14.45	14.10	13.90	13.40	16.0
18.0	12.85	12.70	12.40	12.20	11.90	11.60	11.40	10.95	18.0
20.0	10.85	10.75	10.45	10.25	9.95	9.70	9.45	9.10	20.0
22.0	9.30	9.20	8.85	8.75	8.40	8.20	7.90	7.60	22.0
24.0	8.00	7.90	7.60	7.50	7.15	6.95	6.60	6.40	24.0
26.0	6.95	6.85	6.55	6.45	6.10	5.95	5.60	5.40	26.0
28.0	6.05	6.00	5.65	5.55	5.20	5.10	4.70	4.60	28.0
30.0	5.30	5.25	4.90	4.85	4.45	4.40	4.00	3.90	30.0
32.0	4.65	4.60	4.25	4.20	3.85	3.80	3.35	3.30	32.0
34.0	4.45 /32.6	4.45 /32.6	4.10 /32.6	4.05 /32.6	3.65 /32.6	3.65 /32.6	3.20 /32.6	3.15 /32.6	34.0

Unit: ton loads /working radius

Boom Length (m)	39								Boom Length (m)
Jib Length (m)	10		16		22		28		Jib Length (m)
Offset Angle (deg) Radius (m)	10	30	10	30	10	30	10	30	Offset Angle (deg) Radius (m)
8.0	31.50 /8.8	31.25 /8.8	30.95 /8.8	30.45 /8.8	30.35 /8.8	29.60 /8.8	29.65 /8.8	28.60 /8.8	8.0
9.0	30.75	30.50	30.20	29.75	29.60	28.85	28.90	27.90	9.0
10.0	27.40	27.20	26.90	26.45	26.30	25.65	25.60	24.70	10.0
12.0	22.30	22.15	21.80	21.45	21.25	20.70	20.60	19.85	12.0
14.0	18.60	18.45	18.10	17.80	17.55	17.10	16.90	16.35	14.0
16.0	15.35	15.20	14.95	14.70	14.45	14.05	13.90	13.35	16.0
18.0	12.80	12.70	12.40	12.20	11.90	11.60	11.40	10.95	18.0
20.0	10.80	10.70	10.40	10.25	9.95	9.70	9.45	9.05	20.0
22.0	9.25	9.15	8.85	8.70	8.40	8.15	7.90	7.60	22.0
24.0	7.95	7.85	7.55	7.45	7.10	6.95	6.60	6.35	24.0
26.0	6.90	6.80	6.50	6.40	6.05	5.90	5.55	5.35	26.0
28.0	6.00	5.90	5.60	5.50	5.15	5.05	4.70	4.55	28.0
30.0	5.20	5.15	4.80	4.75	4.40	4.30	3.95	3.80	30.0
32.0	4.55	4.50	4.15	4.10	3.75	3.70	3.30	3.20	32.0
34.0	4.00	3.95	3.60	3.55	3.20	3.15	2.75	2.70	34.0
36.0	3.65 /35.2	3.65 /35.2	3.30 /35.2	3.30 /35.2	2.90 /35.2	2.85 /35.2	2.45 /35.2	2.45 /35.2	36.0

\* For notes about the table above, refer to page 36.

■ Main Boom with Crane Jib



Unit: ton loads /working radius

Boom Length (m)	42								Boom Length (m)
Jib Length (m)	10		16		22		28		Jib Length (m)
Offset Angle (deg) Radius (m)	10	30	10	30	10	30	10	30	Offset Angle (deg) Radius (m)
	9.0	28.45 /9.4	28.20 /9.4	27.90 /9.4	27.45 /9.4	27.30 /9.4	26.65 /9.4	26.65 /9.4	
10.0	26.60	26.35	26.05	25.65	25.50	24.85	24.85	23.95	10.0
12.0	21.65	21.45	21.15	20.80	20.60	20.05	19.95	19.25	12.0
14.0	18.05	17.85	17.55	17.25	17.00	16.55	16.40	15.80	14.0
16.0	15.15	15.00	14.70	14.45	14.25	13.85	13.65	13.15	16.0
18.0	12.55	12.45	12.15	11.95	11.70	11.35	11.20	10.75	18.0
20.0	10.60	10.50	10.20	10.00	9.75	9.45	9.25	8.85	20.0
22.0	9.00	8.90	8.60	8.45	8.15	7.95	7.65	7.35	22.0
24.0	7.70	7.65	7.30	7.20	6.90	6.70	6.40	6.15	24.0
26.0	6.65	6.55	6.25	6.15	5.80	5.65	5.35	5.10	26.0
28.0	5.75	5.65	5.35	5.25	4.90	4.80	4.45	4.30	28.0
30.0	4.95	4.90	4.60	4.50	4.15	4.05	3.70	3.55	30.0
32.0	4.30	4.25	3.90	3.85	3.50	3.40	3.05	2.95	32.0
34.0	3.70	3.70	3.35	3.30	2.95	2.90	2.50	2.40	34.0
36.0	3.20	3.20	2.85	2.80	2.45	2.40	2.20 /35.2	2.20 /34.8	36.0
38.0	2.80 /37.8	2.80 /37.8	2.45 /37.8	2.45 /37.8	2.20 /37.1	2.20 /37.0			38.0

Unit: ton loads /working radius

Boom Length (m)	45								Boom Length (m)
Jib Length (m)	10		16		22		28		Jib Length (m)
Offset Angle (deg) Radius (m)	10	30	10	30	10	30	10	30	Offset Angle (deg) Radius (m)
	9.0	26.15 /9.9	25.90 /9.9	25.65 /9.9	25.20 /9.9	25.05 /9.9	24.40 /9.9	24.45 /9.9	
10.0	25.85	25.60	25.35	24.95	24.80	24.15	24.15	23.25	10.0
12.0	21.10	20.90	20.60	20.25	20.05	19.55	19.45	18.70	12.0
14.0	17.55	17.40	17.10	16.80	16.55	16.10	15.95	15.35	14.0
16.0	14.85	14.75	14.40	14.15	13.90	13.50	13.30	12.80	16.0
18.0	12.45	12.30	12.00	11.80	11.55	11.25	11.05	10.60	18.0
20.0	10.45	10.30	10.05	9.85	9.60	9.30	9.10	8.70	20.0
22.0	8.85	8.75	8.45	8.30	8.00	7.80	7.55	7.20	22.0
24.0	7.55	7.45	7.15	7.05	6.75	6.55	6.25	6.00	24.0
26.0	6.50	6.40	6.10	6.00	5.65	5.50	5.20	4.95	26.0
28.0	5.55	5.50	5.20	5.10	4.80	4.65	4.30	4.10	28.0
30.0	4.80	4.75	4.40	4.35	4.00	3.90	3.55	3.40	30.0
32.0	4.15	4.10	3.75	3.70	3.35	3.25	2.90	2.80	32.0
34.0	3.55	3.50	3.20	3.15	2.80	2.70	2.35	2.25	34.0
36.0	3.05	3.00	2.70	2.65	2.30	2.25	2.20 /34.6	2.20 /34.2	36.0
38.0	2.60	2.55	2.25	2.20	2.20 /36.4	2.20 /36.2			38.0
40.0	2.20	2.20	2.20 /38.2						40.0

\* For notes about the table above, refer to page 36.

■ Main Boom with Crane Jib



Unit: ton loads /working radius

Boom Length (m)	48								Boom Length (m)
Jib Length (m)	10		16		22		28		Jib Length (m)
Offset Angle (deg) Radius (m)	10	30	10	30	10	30	10	30	Offset Angle (deg) Radius (m)
	10.0	23.90 /10.5	23.65 /10.5	23.40 /10.5	23.00 /10.5	22.85 /10.5	22.25 /10.5	22.20 /10.5	
12.0	20.55	20.35	20.10	19.75	19.55	19.00	18.95	18.20	12.0
14.0	17.15	16.95	16.65	16.35	16.15	15.70	15.55	14.95	14.0
16.0	14.50	14.35	14.05	13.80	13.55	13.15	12.95	12.45	16.0
18.0	12.30	12.15	11.90	11.65	11.45	11.10	10.90	10.45	18.0
20.0	10.30	10.20	9.90	9.70	9.45	9.15	9.00	8.55	20.0
22.0	8.70	8.60	8.30	8.15	7.90	7.65	7.40	7.05	22.0
24.0	7.40	7.30	7.05	6.90	6.60	6.40	6.15	5.85	24.0
26.0	6.35	6.25	5.95	5.85	5.55	5.35	5.10	4.85	26.0
28.0	5.45	5.35	5.05	4.95	4.65	4.50	4.20	4.00	28.0
30.0	4.65	4.60	4.30	4.20	3.90	3.75	3.45	3.25	30.0
32.0	4.00	3.95	3.60	3.55	3.20	3.10	2.80	2.65	32.0
34.0	3.40	3.35	3.05	2.95	2.65	2.55	2.20	2.20 /33.6	34.0
36.0	2.90	2.85	2.55	2.50	2.20 /35.8	2.20 /35.4			36.0
38.0	2.45	2.40	2.20 /37.5	2.20 /37.3					38.0
40.0	2.20 /39.2	2.20 /39.0							40.0

Unit: ton loads /working radius

Boom Length (m)	51								Boom Length (m)
Jib Length (m)	10		16		22		28		Jib Length (m)
Offset Angle (deg) Radius (m)	10	30	10	30	10	30	10	30	Offset Angle (deg) Radius (m)
	10.0	20.45 /11.1	20.35 /11.1	19.85 /11.1	19.70 /11.1	19.20 /11.1	18.95 /11.1	18.45 /11.1	
12.0	19.85	19.65	19.40	19.05	18.75	18.35	18.00	17.55	12.0
14.0	16.55	16.35	16.05	15.75	15.55	15.10	15.00	14.35	14.0
16.0	13.95	13.80	13.50	13.25	13.00	12.60	12.45	11.90	16.0
18.0	11.90	11.80	11.45	11.25	10.95	10.65	10.45	9.95	18.0
20.0	10.20	10.05	9.80	9.60	9.30	9.00	8.80	8.40	20.0
22.0	8.60	8.45	8.20	8.00	7.75	7.50	7.30	6.95	22.0
24.0	7.25	7.20	6.90	6.75	6.50	6.25	6.00	5.70	24.0
26.0	6.20	6.10	5.80	5.70	5.40	5.20	4.95	4.70	26.0
28.0	5.25	5.20	4.90	4.80	4.50	4.35	4.05	3.80	28.0
30.0	4.50	4.40	4.10	4.00	3.70	3.55	3.30	3.10	30.0
32.0	3.80	3.75	3.45	3.35	3.05	2.95	2.65	2.45	32.0
34.0	3.20	3.15	2.85	2.80	2.50	2.35	2.20 /33.5	2.20 /32.9	34.0
36.0	2.70	2.65	2.35	2.30	2.20 /35.0	2.20 /34.6			36.0
38.0	2.25	2.20	2.20 /36.6	2.20 /36.4					38.0
40.0	2.20 /38.2								40.0

\* For notes about the table above, refer to page 36.



■ Main Boom (Using Third Winch)



Unit: ton loads /working radius

Working Radius(m)	Boom Length (m)										Working Radius(m)
	12	15	18	21	24	27	30	33	36	39	
3.8	90.00										3.8
4.0	90.00										4.0
4.5	84.40	84.40									4.5
5.0	75.95	75.95	75.95								5.0
5.5	69.05	69.05	68.80	65.70 /5.6							5.5
6.0	63.30	63.30	62.85	60.75	57.25 /6.1	49.85 /6.7					6.0
7.0	54.10	54.10	53.00	51.15	49.30	47.60	44.65 /7.2	39.65 /7.8			7.0
8.0	44.90	44.90	44.75	44.05	42.60	41.25	39.95	38.65	36.00 /8.3	32.95 /8.8	8.0
9.0	38.10	38.05	37.90	37.85	37.45	36.35	35.30	34.15	33.15	32.20	9.0
10.0	33.00	32.90	32.75	32.70	32.60	32.40	31.55	30.55	29.70	28.90	10.0
12.0	26.50 /11.8	25.80	25.60	25.55	25.40	25.35	25.15	25.00	24.40	23.80	12.0
14.0		21.10	20.90	20.80	20.65	20.60	20.40	20.25	20.00	20.00	14.0
16.0		20.30 /14.4	17.50	17.45	17.25	17.20	17.00	16.85	16.60	16.55	16.0
18.0			16.20 /17.0	14.90	14.75	14.65	14.45	14.30	14.05	14.00	18.0
20.0				13.35 /19.6	12.80	12.70	12.50	12.30	12.05	12.05	20.0
22.0					11.25	11.10	10.90	10.70	10.50	10.45	22.0
24.0					11.10 /22.2	9.85	9.65	9.45	9.20	9.15	24.0
26.0						9.40 /24.8	8.60	8.35	8.10	8.10	26.0
28.0							7.95 /27.4	7.45	7.20	7.15	28.0
30.0								6.70	6.45	6.40	30.0
32.0									5.80	5.75	32.0
34.0									5.60 /32.6	5.15	34.0
36.0										4.85 /35.2	36.0

Unit: ton loads /working radius

Working Radius(m)	Boom Length (m)							Working Radius(m)
	42	45	48	51	54	57	60	
9.0	29.90 /9.4	27.60 /9.9						9.0
10.0	28.05	27.35	25.35 /10.5	23.10 /11.1	19.85 /11.6			10.0
12.0	23.15	22.55	22.05	21.35	19.65	18.55 /12.2	14.90 /12.7	12.0
14.0	19.50	19.05	18.65	18.05	17.60	17.15	14.40	14.0
16.0	16.35	16.20	16.00	15.45	15.10	14.70	13.70	16.0
18.0	13.80	13.65	13.50	13.40	13.05	12.75	12.35	18.0
20.0	11.80	11.65	11.50	11.40	11.25	11.15	10.75	20.0
22.0	10.20	10.05	9.95	9.80	9.65	9.55	9.30	22.0
24.0	8.90	8.75	8.65	8.50	8.35	8.20	8.00	24.0
26.0	7.85	7.70	7.55	7.40	7.25	7.15	6.90	26.0
28.0	6.95	6.80	6.65	6.50	6.35	6.20	6.00	28.0
30.0	6.15	6.00	5.85	5.70	5.55	5.40	5.20	30.0
32.0	5.50	5.35	5.20	5.05	4.90	4.75	4.50	32.0
34.0	4.90	4.75	4.60	4.45	4.30	4.15	3.90	34.0
36.0	4.40	4.25	4.10	3.90	3.75	3.60	3.40	36.0
38.0	4.00 /37.8	3.75	3.65	3.45	3.30	3.15	2.90	38.0
40.0		3.35	3.20	3.05	2.90	2.75	2.50	40.0
42.0		3.30 /40.4	2.85	2.65	2.50	2.35	2.15	42.0
44.0			2.70 /43.0	2.35	2.20	2.05	1.80	44.0
46.0				2.15 /45.3	1.90	1.75	1.70 /44.8	46.0
48.0					1.70 /47.4	1.70 /46.3		48.0

1. The rated loads are determined according to EN13000 rating on the condition that the machine is stationed on firm, level ground.
2. The figures surrounded by bold lines are based on factors other than those which would cause a tipping condition.
3. To calculate the maximum load that can actually be lifted, deduct weight of all lifting accessories, such as boom hook and jib hook, from figures shown above.
4. Working radius is the horizontal distance from the slewing center to the center of gravity of a lifted load.
5. The counter weight is 49.5 tons. (Upper weight 37.5 tons + Lower weight 12.0 tons)
6. Correlation between the number of reeved lines, maximum rated loads, hook weights are shown in the table below.

Hook Capacity (t)	Hook Weight (t)	Maximum Rated Loads (t)						
		8 falls	7 falls	6 falls	5 falls	4 falls	3 falls	2 falls
100	1.20	100	84	72	60	48	-	-
50	1.17	-	-	-	50	48	36	24
35	0.90	-	-	-	-	-	35	24

7. When performing repetitive work using buckets, lifting magnets, etc., the higher the load factor, the shorter the life of the structure (boom, frame, winch, etc.).

■ Main Boom with Aux. Sheave (Using Third Winch)



Unit: ton loads /working radius

Working Radius(m)	Boom Length (m)										Working Radius(m)	
	12	15	18	21	24	27	30	33	36	39		
3.8	90.00											3.8
4.0	90.00											4.0
4.5	84.40	84.40										4.5
5.0	75.95	75.95	75.95									5.0
5.5	69.05	69.05	68.80	65.10 /5.6								5.5
6.0	63.30	63.30	62.80	60.20	56.65 /6.1	49.25 /6.7						6.0
7.0	54.10	54.10	52.45	50.55	48.70	47.00	44.05 /7.2	39.05 /7.8				7.0
8.0	44.50	44.45	44.30	43.50	42.00	40.70	39.40	38.05	35.40 /8.3	32.35 /8.8		8.0
9.0	37.70	37.65	37.45	37.40	36.85	35.75	34.70	33.55	32.55	31.60		9.0
10.0	32.60	32.55	32.35	32.30	32.15	31.85	30.95	29.95	29.05	28.25		10.0
12.0	26.10 /11.8	25.40	25.20	25.15	25.00	24.90	24.70	24.50	23.80	23.15		12.0
14.0		20.70	20.50	20.40	20.25	20.15	19.95	19.80	19.55	19.45		14.0
16.0		19.95 /14.4	17.15	17.05	16.85	16.75	16.55	16.40	16.15	16.10		16.0
18.0			15.80 /17.0	14.55	14.35	14.25	14.05	13.85	13.60	13.55		18.0
20.0				12.95 /19.6	12.40	12.25	12.05	11.85	11.60	11.55		20.0
22.0					10.85	10.70	10.50	10.30	10.05	10.00		22.0
24.0					10.70 /22.2	9.45	9.25	9.00	8.75	8.70		24.0
26.0						9.00 /24.8	8.20	7.95	7.70	7.65		26.0
28.0							7.55 /27.4	7.05	6.80	6.75		28.0
30.0								6.30	6.05	5.95		30.0
32.0									5.40	5.30		32.0
34.0									5.20 /32.6	4.75		34.0
36.0										4.45 /35.2		36.0

Unit: ton loads /working radius

Working Radius(m)	Boom Length (m)						Working Radius(m)
	42	45	48	51	54	57	
9.0	29.25 /9.4	26.95 /9.9					9.0
10.0	27.40	26.70	24.70 /10.5	22.10 /11.1	18.85 /11.6		10.0
12.0	22.50	21.90	21.40	20.70	18.65	17.50 /12.2	12.0
14.0	18.90	18.40	17.95	17.35	16.90	16.45	14.0
16.0	15.85	15.70	15.35	14.80	14.40	14.00	16.0
18.0	13.30	13.15	13.00	12.75	12.40	12.05	18.0
20.0	11.35	11.15	11.00	10.90	10.75	10.45	20.0
22.0	9.75	9.60	9.45	9.30	9.15	9.00	22.0
24.0	8.45	8.30	8.15	8.00	7.85	7.70	24.0
26.0	7.40	7.20	7.05	6.90	6.75	6.60	26.0
28.0	6.50	6.30	6.15	6.00	5.85	5.70	28.0
30.0	5.70	5.55	5.40	5.20	5.05	4.90	30.0
32.0	5.05	4.85	4.70	4.55	4.40	4.20	32.0
34.0	4.45	4.30	4.15	3.95	3.80	3.65	34.0
36.0	3.95	3.80	3.60	3.45	3.25	3.10	36.0
38.0	3.55 /37.8	3.35	3.15	3.00	2.80	2.65	38.0
40.0		2.95	2.80	2.55	2.40	2.25	40.0
42.0		2.85 /40.4	2.45	2.20	2.20 /41.2	2.20 /40.3	42.0
44.0			2.25 /43.0	2.20 /42.2			44.0

1. The rated loads are determined according to EN13000 rating on the condition that the machine is stationed on firm, level ground.
2. The figures surrounded by bold lines are based on factors other than those which would cause a tipping condition.
3. To calculate the maximum load that can actually be lifted, deduct weight of all lifting accessories, such as boom hook and jib hook, from figures shown above.
4. Working radius is the horizontal distance from the slewing center to the center of gravity of a lifted load.
5. The counter weight is 49.5 tons. (Upper weight 37.5 tons + Lower weight 12.0 tons)
6. Correlation between the number of reeved lines, maximum rated loads, hook weights are shown in the table below.

Hook Capacity (t)	Hook Weight (t)	Maximum Rated Loads (t)						
		8 falls	7 falls	6 falls	5 falls	4 falls	3 falls	2 falls
100	1.20	100	84	72	60	48	-	-
50	1.17	-	-	-	50	48	36	24
35	0.90	-	-	-	-	-	35	24

7. When performing repetitive work using buckets, lifting magnets, etc., the higher the load factor, the shorter the life of the structure (boom, frame, winch, etc.).
8. If the value is less than 1.4 tons after deduction of jib hook weight from the rated load shown above, operation is not available.

# Clamshell Specifications

## Dimensions and Specifications

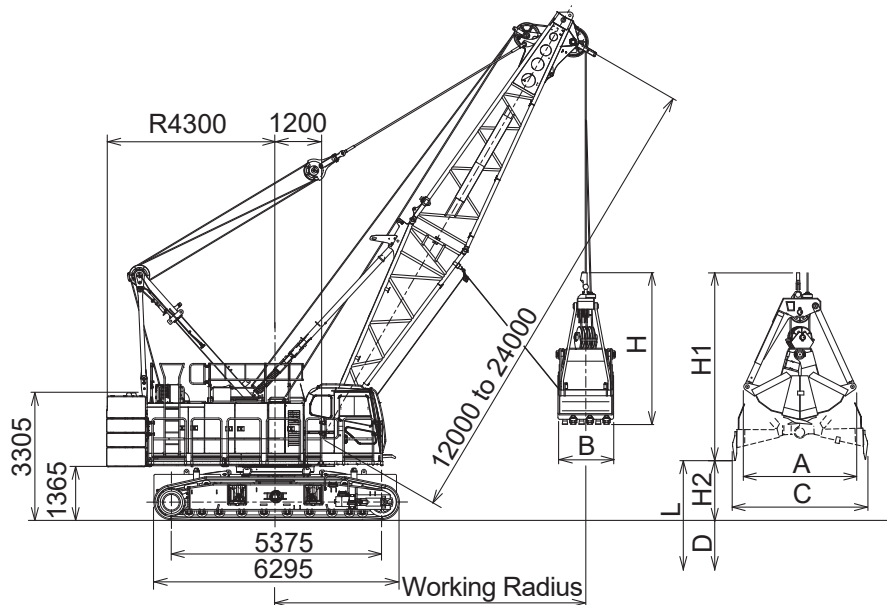

### Working Ranges

Boom Length	m	12				15				18				21				24			
Boom Angle	°	35	45	55	65	35	45	55	65	35	45	55	65	35	45	55	65	35	45	55	65
Working Radius	m	11.6	10.4	8.8	7.1	14.0	12.5	10.5	8.4	16.5	14.6	12.3	9.6	19.0	16.7	14.0	10.9	21.4	18.8	15.7	12.2
Gross Rated Load	t	10.0	10.0	10.0	10.0	10.0	10.0	10.0	10.0	10.0	10.0	10.0	10.0	10.0	10.0	10.0	10.0	9.3	10.0	10.0	10.0
Lift L (D + H2)	m	37.2	38.8	40.2	41.4	38.8	40.9	42.6	44.0	40.4	42.9	45.0	46.7	42.0	44.9	47.4	49.3	43.6	47.0	49.8	52.0
Max. Digging Depth D	m	36																			
Bucket Dumping Height H2	m	1.2	2.8	4.2	5.4	2.8	4.9	6.6	8.0	4.4	6.9	9.0	10.7	6.0	8.9	11.4	13.3	7.6	11.0	13.8	16.0

### Specifications

Clamshell Specifications	
Bucket Capacity	m <sup>3</sup> 3.0
Allowed Maximum Gross Weight for Clamshell Bucket and Captured Load Combined	t 10
Boom Length	m 12 to 24
Maximum Digging Depth	m 36
Ground Contact Pressure	kPa (kgf/cm <sup>2</sup> ) 117(1.19) (w/ Basic Boom, 3.0 m <sup>3</sup> Clamshell Bucket)
Overall Operating Weight	t Approximately 104 (w/ Basic Boom, 3.0 m <sup>3</sup> Clamshell Bucket)

NOTE :

- SI units are used for specifications. In parenthesis, conventional units are also indicated.

### Clamshell Bucket

Capacity (m <sup>3</sup> )	Weight (t)	A (mm)	B (mm)	C (mm)	H (mm)	H1 (mm)
3.0	6.5	2,980	1,650	3,500	3,550	4,550

### Gross Rated Load Table

Working Radius (m)	Boom Length (m)				
	12	15	18	21	24
7.1	10.00/7.1				
8.0	10.00	10.00/8.4			
9.0	10.00	10.00	10.00/9.6		
10.0	10.00	10.00	10.00	10.00/10.9	
12.0	10.00/11.6	10.00	10.00	10.00	10.00/12.2
14.0		10.00	10.00	10.00	10.00
16.0			10.00	10.00	10.00
18.0			10.00/16.5	10.00	10.00
20.0				10.00/19.0	10.00
21.4					9.30/21.4

- The mass of the individual bucket shall not exceed 6.5 t.
- Max. clamshell rating is 10.0 t.
- Mass of bucket plus load should not exceed clamshell ratings shown above. Following data are for a general digging application buckets.

Bucket Capacity	2.0 m <sup>3</sup>	2.5 m <sup>3</sup>	3.0 m <sup>3</sup>
Bucket Mass	4.5 t	5.5 t	6.5 t

- In case of clamshell application, a 12 m boom is recommended as minimum length of boom, and max. boom length shall not exceed 24 m.
- Apparent specific gravity of lifting material :  
Earth ..... 1.7 to 1.8 t/m<sup>3</sup>  
Gravel ..... 1.8 to 2.0 t/m<sup>3</sup>
- Upper weights should be used in an assembly configuration (31.2 t) excluding right and left top weights.
- Max. digging depth below ground shall be 36 m.

# Weights and Dimensions of Disassembled Units

## Weights and Dimensions List

Comply with the regulations when transporting.  
"Weight" refers to the mass of each single unit.

Weights and Dimensions of Disassembled Units

○ : With    - : Without

Description		Qty	Dimensions (mm)		Weight (kg)
Base Crane	○	1			50800
Boom Base	○				
Backstop	○				
Front Winch Wire Rope	○				
Rear Winch Wire Rope	○				
Boom Hoist Winch Wire Rope	○				
Crawler	○				
Jack	○				
Float	-				
Base Crane	○				
Boom Base	-				
Backstop	-				
Front Winch Wire Rope	○				
Rear Winch Wire Rope	○				
Boom Hoist Winch Wire Rope	○				
Crawler	○				
Jack	○				
Float	-				
Base Crane	○	1			31700
Boom Base	○				
Backstop	○				
Front Winch Wire Rope	○				
Rear Winch Wire Rope	○				
Boom Hoist Winch Wire Rope	○				
Crawler	-				
Jack	○				
Float	-				
Base Crane	○				
Boom Base	-				
Backstop	-				
Front Winch Wire Rope	○				
Rear Winch Wire Rope	○				
Boom Hoist Winch Wire Rope	○				
Crawler	-				
Jack	○				
Float	-				
Crawler		2			9600

- With upper house handrails, the weight of the main unit increases by 160 kg.
- With catwalks, the weight of the main unit increases by 310 kg and the width of the main unit increases by 210 mm.

Weights and Dimensions of Disassembled Units

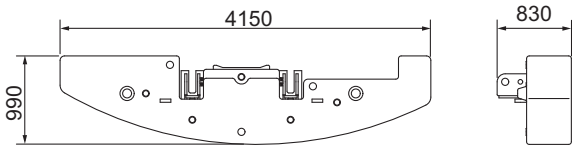
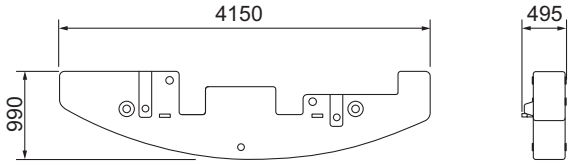
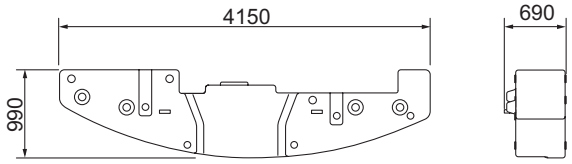
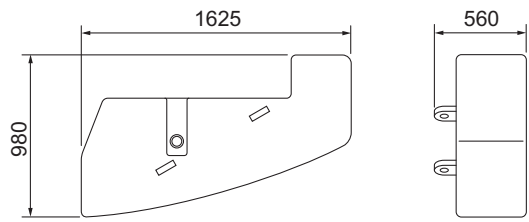
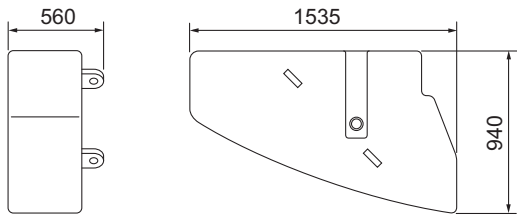
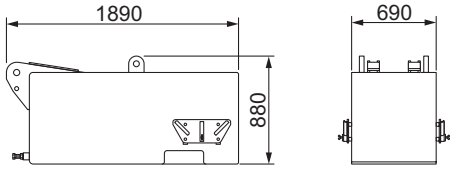
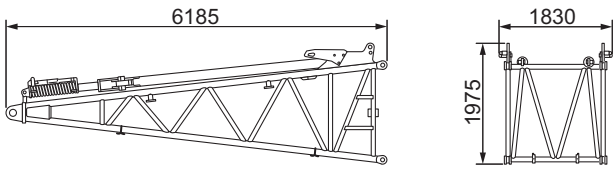
Description	Qty	Dimensions (mm)	Weight (kg)
Counter Weight A	1		9420
Counter Weight B	2		6640
Counter Weight C	1		8980
Counter Weight D (Right)	1		2810
Counter Weight D (Left)	1		3000
Lower Weight	2		6040
Boom Base	1		1720

Weights and Dimensions of Disassembled Units

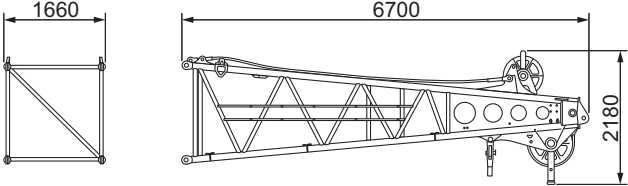
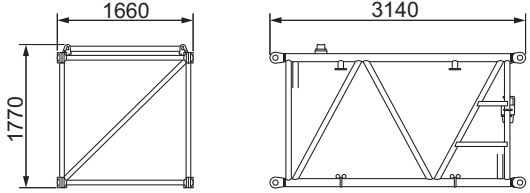
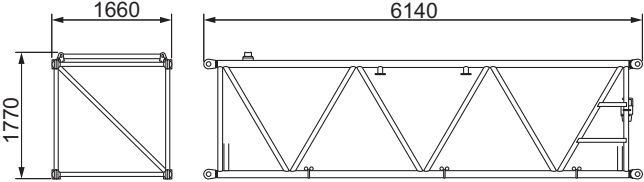
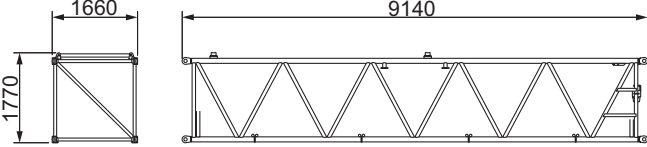
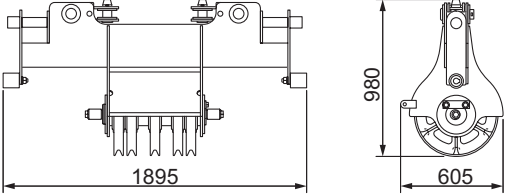
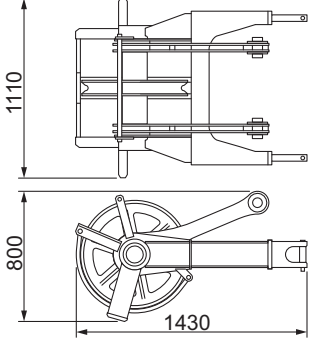
Description	Qty	Dimensions (mm)	Weight (kg)
Boom Top	1		1650
3 m Boom Insert	1		430
6 m Boom Insert	1		690
9 m Boom Insert	1		1000
Upper Spreader	1		490
Aux. Sheave	1		340

Weights and Dimensions of Disassembled Units

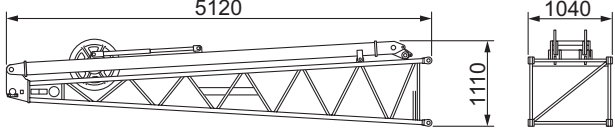
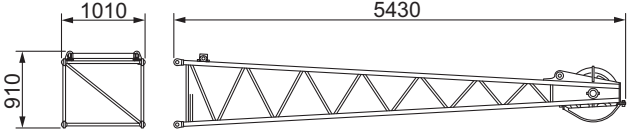
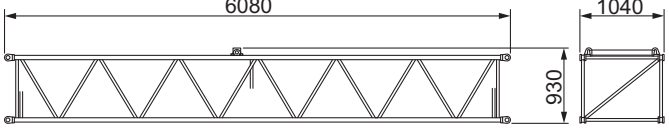
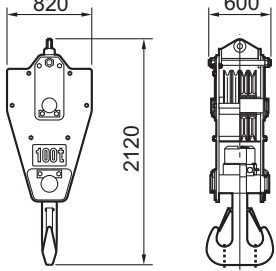
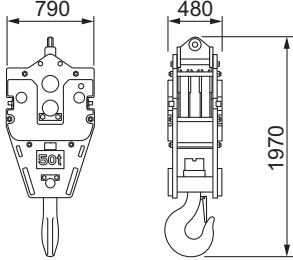
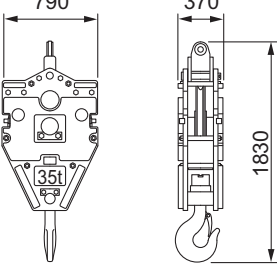
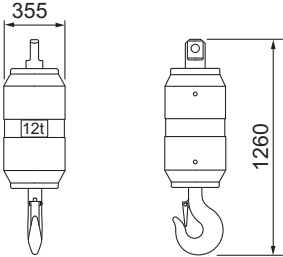
Description	Qty	Dimensions (mm)	Weight (kg)
Jib Base (with Jib Strut)	1		580
Jib Top	1		290
6 m Jib Insert	1		190
100 t Hook	1		1200
50 t Hook	1		1170
35 t Hook	1		900
12 t Hook	1		510

# Equipment List

## Standard and Optional Equipment

○ : Standard ● : Optional — : No setting

Item		Crane	Clamshell
Lower Structure	810 mm Shoe	○	○
	Jack Up Unit	○	○
	Crawler Extension / Retraction System	○	○
	Steps	○	○
	Shoe Tension Unit (Hydraulic)	●	●
	Low Wear Shoe (Contiguous Surface of Roller)	●	●
Upper Structure	Clearance bar	●	●
	Cab Up / Down Catwalk	○	○
	Under Cover (Bed Lower Surface)	○	○
	Working Light (× 2)	○	○
	Additional Working Light (× 2)	●	●
	Back Mirror (Left / Right)	○	○
	Central Lubrication Unit (for Turntable Bearing)	○	○
	Drum Flange Cover	○	○
	Auto Idle Stop	○	○
	Eco Winch	○	○
	Drum Mirror	●	●
	Drum Light (Front Winch)	●	●
	Winch Rope Retainer (Front Winch)	●	●
	Winch Rope Retainer (Rear Winch)	●	●
	Winch Rope Retainer (Third Winch)	●	●
	Catwalk with Handrails (Folding Type, Left / Right)	○	○
	Upper House Handrails	○	○
	Counterweight Handrails <sup>*1</sup>	●	●
	Electric Fuel Pump	●	●
	Electric Urea Pump	●	●
Winch with Front and Rear Free Mechanism (Brake Mode Switch, with Free-fall Assist System)	●	●	
Third Winch (Rope not Included)	●	-	
Cab	Air Conditioner	○	○
	Sunvisor	○	○
	Sunshade	○	○
	Wiper with Washer (Front Window, Cab Roof Window)	○	○
	Microphone & Loud-speaker	●	●
	AM / FM Radio (with Clock)	○	○
	Room Lamp	○	○
	Cup Holder	○	○
	24 V Power Socket (× 2)	○	○
	Floor Carpet	○	○
	Level Gauge (in Cab & Lower Frame)	○	○
	Accelerator Pedal (Right Side)	●	●
	Arm Chair Lever	○	○
	Cross Operation Lever (Lever Lock not Attached) <sup>*2</sup>	●	●
	Front Operation Lever (with Lever Lock)	●	●
	Standard Seat	○	○
	Seat with Suspension	●	●
	Travel Operation Pedal (Cannot be installed when winch with free mechanism attached)	●	●
	Boom Hoist Operation Pedal <sup>*3</sup>	●	●
	Swing Brake Operation Pedal <sup>*3</sup>	●	●
	Fan	●	●
	Front / Rear Operation Lever, Brake Pedal Permutation	●	●
	Fuel Burning Heater	●	●
	Accelerator Grip	○	○
Drum Rotation Sensor (Front / Rear / Boom Hoist) <sup>*4</sup>	○	○	
Speed Control Dial (Front / Rear/Boom Hoist / Swing)	○	○	
Life Hammer	○	○	

\*1 Can be installed on top of the counter weight with the exception of reduction counter weight specification.

\*2 Cross operation lever can operate front, rear, boom hoist, and swing.

\*3 Cannot be installed at the same time.

\*4 Cannot be equipped when the cross operation lever or front operation lever is installed.



○ : Standard ● : Optional — : No setting

Item		Crane	Clamshell	
Attachment	12 m Basic Boom (Boom Base: 6 m, Top: 6 m)	○	○	
	3 m Boom Insert	●	●	
	6 m Boom Insert	●	●	
	9 m Boom Insert	●	●	
	Parts Set for 10 m Crane Jib [10 m Basic Jib, Anti-two Block, Jib Mast]	●	-	
	6 m Crane Jib Insert	●	-	
	Parts Set for Auxiliary Sheave [Auxiliary Sheave, Auxiliary Sheave Anti-two Block]	●	-	
	100 t Hook (4 Sheaves)	●	-	
	50 t Hook (3 Sheaves)	●	-	
35 t Hook (1 Sheave)	●	-		
12 t Hook	●	-		
Wire Rope	Front Winch ( φ 26)	P · S (19) + 39XP · 7	○	-
		IWRC 6 X WS (31)	-	○ <sup>*5</sup>
	Rear Winch ( φ 26)	Mono Rope EP 3XF (40)	●	-
		P · S (19) + 39XP · 7	●	-
		IWRC 6 X P · WS (31)	-	○ <sup>*6</sup>
	Third Winch ( φ 26)	Mono Rope EP 3XF (40)	●	-
		P · S (19) + 39XP · 7	●	-
Boom Hoist Winch ( φ 22.4)	IWRC 6 X P · WS (31)	○	○	
Safety Device	Moment Limiter	○	○	
	3 Color Percentage Indicator Light	●	●	
	Gate Lock Lever	○	○	
	Individual Operation Lever Lock (Front, Rear, Hoist, Travel) <sup>*7</sup>	○	○	
	Automatic Drum Lock (Boom Hoist)	○	○	
	Winch Drum Lock (Front/Rear)	○	○	
	Lowering Limiter (Winch Drum Dead Turns Detective Device)	●	●	
	Swing Lock	○	○	
	Swing Alarm	○	○	
	Travel Alarm	○	○	
	Auto Slowdown (Slow Stop)	○	○	
	Boom Hoist Limiting Device	○	○	
	Secondary Boom Over Hoist Prevent Device	○	○	
	Warning Alarm	○	○	
	Engine Start Interlock System	○	○	
	Emergency Engine Stop Switch (In cab)	○	○	
	Lifting Height Indication Device	○	○	
	Swing Neutral Free / Brake Selection Switch	○	○	
	Anti-two Block	○	-	
	Moment Limiter (M/L) Mode Selector (In Left House)	●	○	
Swing Restriction Unit	●	●		
Anemometer	○	-		
Obstacle Lights (Fixed lights)	●	-		
Drum and Rear View Monitor System	●	●		
Cab Roof Window Guard	●	●		

\*5 Used for opening/closing rope. 82 m length rope required for 12 m digging depth with 21 m boom length.

\*6 Used for supporting rope. 70 m length rope required for 12 m digging depth with 21 m boom length.

\*7 An operation lever lock is not attached to the front, rear or hoist when the cross operation lever is installed.

○ : Standard ● : Optional — : No setting

Item		Crane	Clamshell
Common Parts	Boom Back Stop	○	○
	Boom Angle Sensor	○	○
	Boom Lifting Piece	○	○
	Remote Sensing (Mobile Communication Terminal, Data Logging Device)	○	○
	Assembly Pad <sup>*8</sup>	●	-
	Reduction Counter Weight Specification	● <sup>*9</sup>	-
	Skywalk (with Stanchion)	●	-
	Skywalk (without Stanchion)	●	-
	Boom Top Under Surface Buffer (Protector)	●	●
	Load Table Sign (Whiteboard, Boom Base Installation)	●	●
	Insertable Company Name Plate (Both Side Surfaces of the Machine)	● <sup>*10</sup>	●
	Opening / Closing / Support Rope Stopper	-	○
	Hyd. Tagline (6 × Fi (29) φ 10 mm × 55 m)	● <sup>*11</sup>	○
	Reeving Winch (4 × F (30) φ 8 mm × 250 m)	● <sup>*11</sup>	-
	Reeving Winch cum Hydraulic Tagline (6 × Fi (29) φ 10 mm × 55 m)	● <sup>*11</sup>	-
	Tagline for Reeving (6 × Fi (29) φ 10 mm × 220 m)		
	Sling Ropes for Disassembly and Assembly (for Counter Weights, Crawlers)	●	●
	Openable Rope Guide (Top Boom)	●	●
	Additional Guide Sheave (1 Sheave)	●	●
	Air Cleaner Double Element	○	○
Additional Fuel Filter (Triple Filter)	●	●	
Additional Spare Parts (Hydraulic Oil Filter)	●	●	
Additional Tools (Large Hammer, Crowbar, Chisel)	●	●	
Other	Standard Supplied Tools	○	○
	Standard Spare Parts	○	○

\*8 The assembly pad is required for the following attachments.

- Crane Boom Length 51 m + Crane Jib 28 m
- Reduction Counter Weight Specification
  - Crane Boom Length 45 m or more
  - Crane Boom Length 42 m or more + Aux. Sheave

\*9 The reduction counter weight specification can only be used for the crane specification, with the exception of the crane jib.

\*10 When it chooses, the width at the time of transportation is set to not less than 3 m.

\*11 (1) Hydraulic tagline (maximum line pull: 2.9 kN (300 kg))

(2) Reeving winch unit (maximum line pull: 11.8 kN (1,200 kg))

(3) Reeving winch and hydraulic tagline

(Line pull: For hydraulic tagline (maximum line pull: 2.9 kN (300 kg)) /for reeving winch (maximum line pull: 2.9 kN (300 kg))

## Standard Equipment for European Specification Only

Item		Crane	Clamshell
European specification	Cross Operation Lever (Lever Lock not Attached) <sup>*1</sup>	○	○
	Seat with Suspension	○	○
	3 Color Percentage Indicator Light	○	○
	Lowering Limiter (Winch Drum Dead Turns Detective Device)	○	○
	Moment Limiter (M/L) Mode Selector (In Left House)	○	○

\*1 Cross operation lever can operate front, rear, boom hoist, and swing.



- We are constantly improving our products and therefore reserve the right to change designs and specifications without notice.
- Units in this specification are shown under International System of Units; the figures in parenthesis are under Gravitational System of Units as old one.

---

## Sumitomo Heavy Industries Construction Cranes Co., Ltd.

9-3, Higashi-Ueno 6-chome, Taito-ku, Tokyo 110-0015, Japan  
Phone: 81-3-3845-1387 Facsimile: 81-3-3845-1394

<https://www.hsc-cranes.com>