

SCX550-3

Stage IV

**SCX
550-3**

HYDRAULIC CRAWLER CRANE



Variation of The Attachment

Line Speed *	Front/Rear Winch (Rated with 6.5 t load)	m/min	110 (53)
	Boom Hoist Winch		60
Swing Speed		min ⁻¹ (rpm)	4.2
Travel Speed High/Low *		km/h	2.0/1.5
Gradeability		% (Degree)	40 (22)
Engine Model			HINO J05E-UN (Stage IV)
Engine Rated Output Power		kW/min ⁻¹ (ps/rpm)	138/2100 (188/2100)

Note : Speeds marked with "*" may vary depending on load applied.

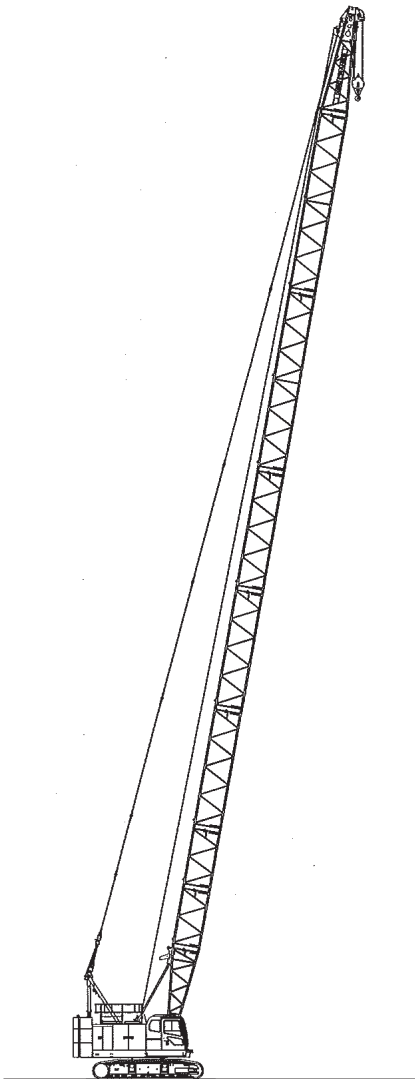

Crane Specification (Boom Longest Length)

Boom Length	m	10 to 49
Ground Contact Pressure	kPa (kgf/cm ²)	76.5 (0.78) (Boom longest length with 15 t hook)
Overall Operating Weight	t	Approximately 55.9 (Boom longest length with 15 t hook)

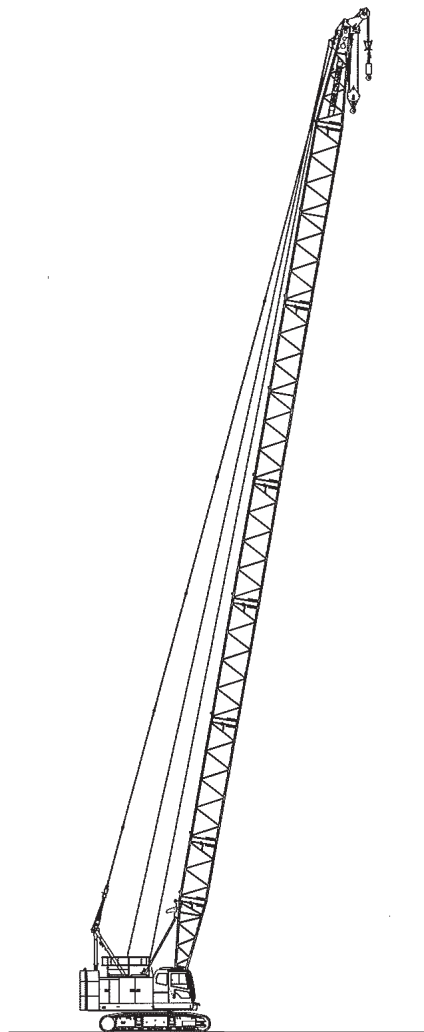

Crane Specification (Boom Longest Length with Aux. Sheave)

Boom Length	m	13 to 46
Ground Contact Pressure	kPa (kgf/cm ²)	76.4 (0.78) (Boom longest length + 15 t aux. sheave + 6.5 t hook attached)
Overall Operating Weight	t	Approximately 55.8 (Boom longest length + 15 t aux. sheave + 6.5 t hook attached)

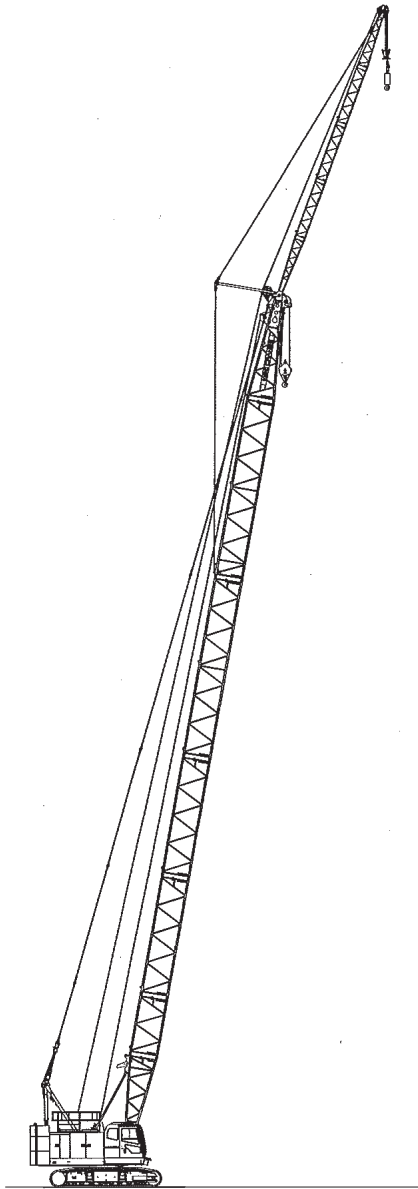

**Crane Specification
(Boom Longest Length with Crane Jib)**

Boom Length	m	22 to 43
Crane Jib Length	m	6 to 15
Boom + Crane Jib Longest Length	m	43 + 15
Ground Contact Pressure	kPa (kgf/cm ²)	77.3 (0.79) (Boom + crane jib longest length 15 t + 6.5 t hook attached)
Overall Operating Weight	t	Approximately 56.5 (Boom + crane jib longest length 15 t + 6.5 t hook attached)

VARIATION

Variation of The Attachment	2
------------------------------------	----------

SPECIFICATIONS

Specifications	6
-----------------------	----------

Crane Specifications	7
-----------------------------	----------

Dimensions and Specifications	7
-------------------------------------	---

Boom and Crane Jib Configurations	8
---	---

Combination of Boom and Crane Jib (Offset Angle 10° and 30°)	10
---	----

Working Ranges.....	11
---------------------	----

■ Main Boom.....	11
------------------	----

■ Aux. Sheave	12
---------------------	----

■ Crane Jib.....	13
------------------	----

Gross Rated Load Table.....	14
-----------------------------	----

■ Main Boom.....	14
------------------	----

■ Aux. Sheave	15
---------------------	----

■ Main Boom with Aux. Sheave.....	16
-----------------------------------	----

■ Crane Jib.....	17
------------------	----

Clamshell Specifications	25
---------------------------------	-----------

Dimensions and Specifications	25
-------------------------------------	----

■ Working Ranges	25
------------------------	----

■ Specifications.....	25
-----------------------	----

■ Clamshell Bucket	25
--------------------------	----

■ Gross Rated Load Table.....	25
-------------------------------	----

TECHNICAL DATA

Weights and Dimensions of Disassembled Units	26
Weights and Dimensions List	26
Equipment List	30
Standard and Optional Equipment	30

Specifications

Engine

Model	HINO J05E-UN
Type	4-cycle, Water-cooled, Direct injection, Turbo-charged, Diesel engine
Displacement	5.123 l
Rated Output	138 kW/2,100 min ⁻¹ (188 ps/2,100 rpm)
Fuel Tank Capacity	300 l
Notes	Compliant with the engine emission gas regulations for EU Stage IV and Japan 2014 Code. Engine rated horsepower is based on the international rating formula which includes necessary horsepower for engine alternator drive but excludes engine fan drive.

Control

Control System	Main actuators are actuated by main hydraulic system controlled with pilot hydraulic system. Safety devices are securely operated by combined various electronic control with hydraulic system. Working speed can be precisely controlled according to control lever stroke and control dials depending on work.
Control Levers	Designed and positioned based on ergonomics. Arm-chair lever type is standard. Cross operation lever type and front lever type are available as option.
Display Panel Design	8 inches size. Located to check work state easily without disturbing the view of the operator.

Hydraulic System

Hydraulic Oil Tank Capacity	260 l		
Hydraulic Pump Capacity	Maximum pressure	29.4 MPa	
	P1	233 l/min	for Front, Rear, boom hoist winch and travel
	P2	233 l/min	for Front, Rear and travel
	P3	153 l/min	for Swing
	P4	43 l/min	Pilot control, Brake cooling, Reeving winch, Hydraulic tagline, etc
P5	34 l/min		

Winch

Front and Rear Winch			
Winch	Front	Rear	
Rope Diameter	22 mm	22 mm	
Rope Length	Standard	185 m	120 m for Aux. sheave
	Winding Capacity	-	120 m for Crane jib
Line Pull	Rated	63.7 kN	63.7 kN

Notes

High-speed winching is possible by ECO winch mode with low engine speed under light loads.
Free fall winch with brake controlled by pedal operation.

Boom Hoist Winch	
Rope Diameter	16 mm
Rope Length	Incorporated 135 m
Note	Hydraulic motor with multi-disc brakes.

Swing System

Consists of a hydraulic motor with reduction gear and multi-disc brakes as well as a swing bearing which has an inner tooth. The optional swing brake pedal enables operators to control swinging operation precisely.

Gantry

Box structure composed of steel square and rectangular tubes for general structure.

Counter Weight

Counter Weight	Total Weight	18.6 t
	8.7 t Base Weight	1
	6.4 t Insert Weight	1
	1.7 t Top Weight (Right)	1
	1.8 t Top Weight (Left)	1

Carbody

Welded steel construction with crawler sideframe extend-retract cylinders.

Crawler Sideframe

Frame	Welded steel box construction	
Shoe	Cast iron 760 mm flat shoe each side	
Upper Roller	2 pieces each side 10 pieces each side	
Lower Roller	Forging heat treated steel with double flange type. 2 plane bearings with floating seal for lifetime lubrication.	
Travel Device	1 piece each side.	
	Hydraulic travel device (Hydraulic motor and reducer)	
	Travel speed (Gradability : 40%)	High : 2.0 km/h Low : 1.5 km/h

Crane Specifications

Dimensions and Specifications

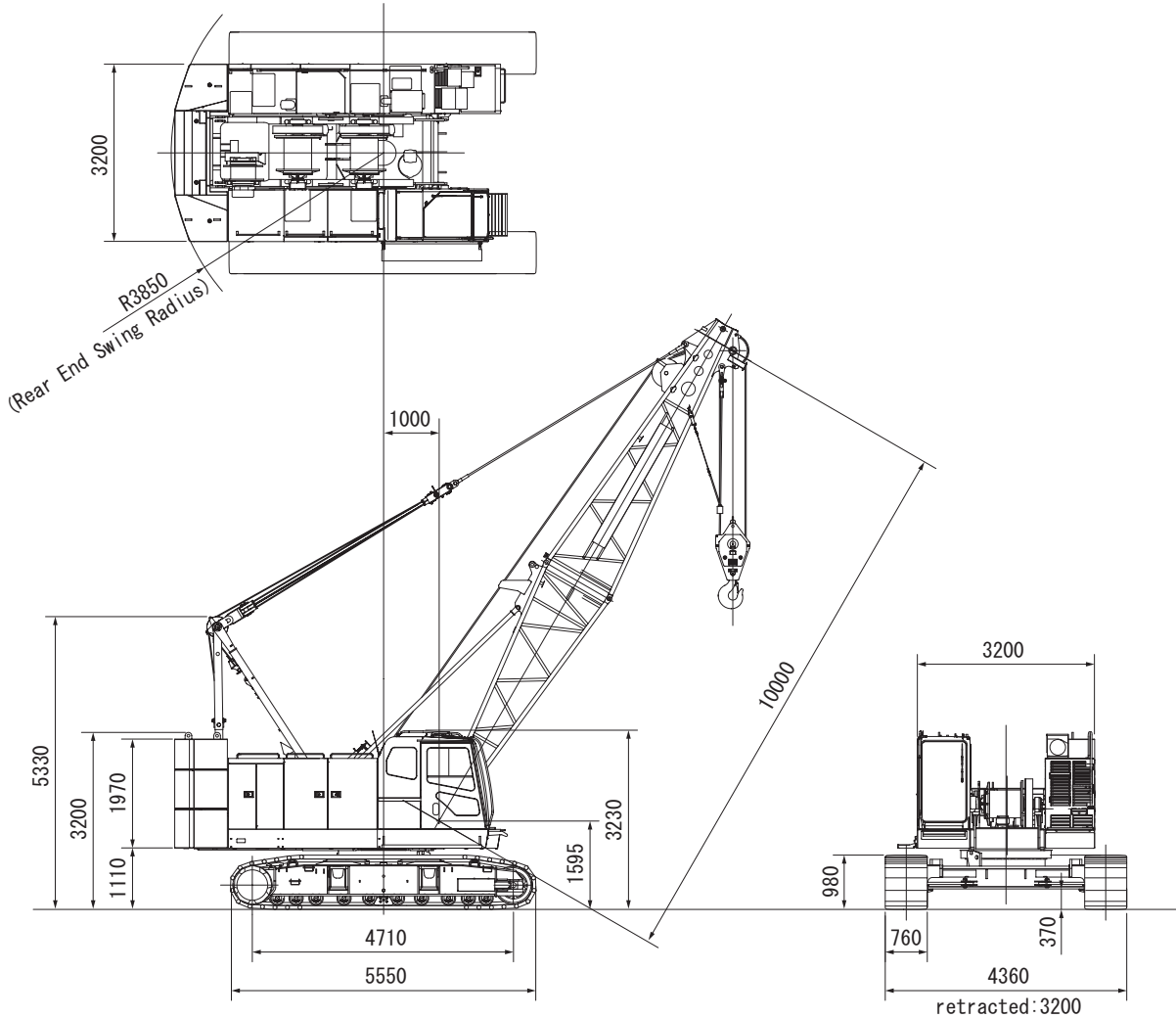

Crane Specifications

Max. Lifting Load × Working Radius	t×m	55 × 3.7
Basic Boom Length	m	10
Max. Boom Length	m	49
Crane Jib Length	m	6 to 15
Max. Boom + Jib Length	m	43 + 15
Ground Contact Pressure	kPa (kgf/cm ²)	73.1 (0.75) (w/Basic Boom, 55 t Hook)
Overall Operating Weight	t	Approximately 53.4 (w/Basic Boom, 55 t Hook)

Hook Weight

55 t	850 kg
30 t	360 kg
15 t	320 kg
6.5 t	180 kg

Note : Data is expressed in SI units followed by conventional units in ().

Front/Rear Winch Rope No. of Falls and Lifting Load

Hook Capacity (t)	Maximum Rated Load (t)								
	9 falls	8 falls	7 falls	6 falls	5 falls	4 falls	3 falls	2 falls	1 fall
55	55.0	52.0	45.5	39.0	32.5	26.0	19.5	13.0	-
30	-	-	-	-	30.0	26.0	19.5	13.0	-
15	-	-	-	-	-	-	15.0	13.0	-
6.5	-	-	-	-	-	-	-	-	6.5

Boom and Crane Jib Configurations

Boom 1/3	
Boom Length (m)	Boom Configurations
10	
13	
16	
19	
22	
25	
28	

Boom 2/3	
Boom Length (m)	Boom Configurations
31	
34	
37	

Boom 3/3

Boom Length (m)	Boom Configurations
40	
43	
46	
49	

Aux. Sheave Installable Boom Length

Boom Length (m)	10	13	16	19	22	25	28	31	34	37	40	43	46	49
With Aux. Sheave	×	○	○	○	○	○	○	○	○	○	○	○	○	×

(○ : Attachable × : Not Attachable)

Check the pendant rope with referring to the imprints on the rope end.

Dimensions Not Shown In The Figure

Symbols	Boom Length (m)	Note
3	3	
5	5	
6	6	
9	9	
9B	9	When equipped with crane jib

Pendant Rope

Length (m)	Rope Diameter (mm)	Imprint
3	28	□ · △ · 28 · 3 · C
4.85	28	□ · △ · 28 · 4.9 · C
6	28	□ · △ · 28 · 6 · C
9	28	□ · △ · 28 · 9 · C

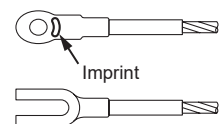

Combination of Boom and Crane Jib (Offset Angle 10° and 30°)

Combination of Boom and Crane Jib (Offset Angle 10° and 30°)

Boom Length (m)	10	13	16	19	22	25	28	36	31	34	37	40	43	46	49
Jib Length (m) 6	x	x	x	x	o	o	o	o	o	o	o	o	o	x	x
Jib Length (m) 9	x	x	x	x	o	o	o	o	o	o	o	o	o	x	x
Jib Length (m) 12	x	x	x	x	o	o	o	o	o	o	o	o	o	x	x
Jib Length (m) 15	x	x	x	x	o	o	o	o	o	o	o	o	o	x	x

(o : Attachable x : Not Attachable)

Crane Jib (Offset Angle 10° and 30°)

Crane Jib Length (m)	Offset Angle	Crane Jib Configurations
6	10°	
	30°	
9	10°	
	30°	
12	10°	
	30°	
15	10°	
	30°	

Check the pendant rope with referring to the imprints on the rope end.

Dimensions Not Shown In The Figure	
Symbols	Jib Length (m)
3	3

Jib Pendant Rope		
Length (m)	Rope Diameter (mm)	Imprint
2.03	20	□ · Δ · 20 · 2.03 · C
5.73	20	□ · Δ · 20 · 5.73 · C
14.0	20	□ · Δ · 20 · 14.00 · C
27.9	20	□ · Δ · 20 · 27.90 · C

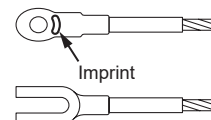

Working Ranges

■ Main Boom

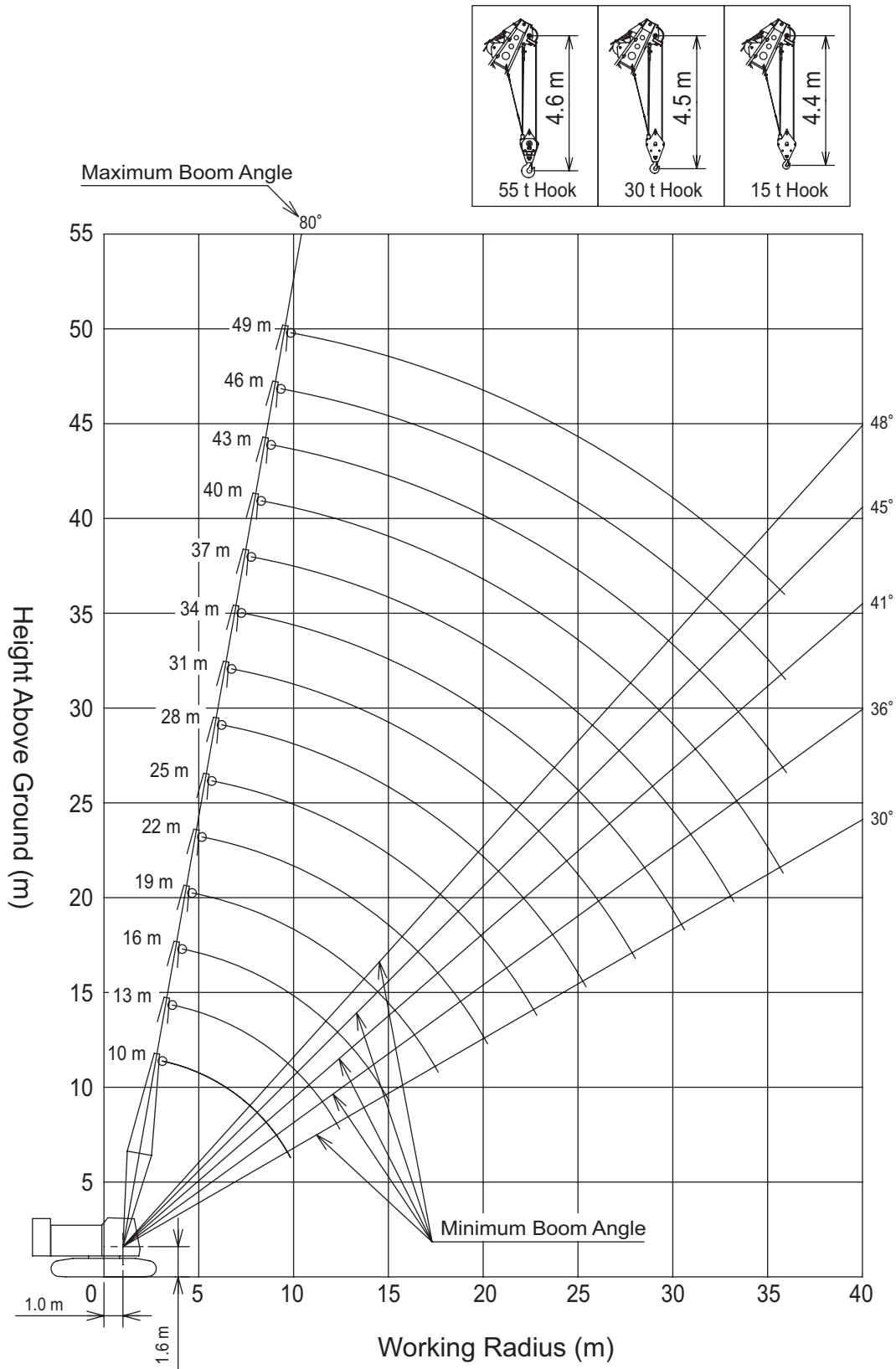

■ Aux. Sheave

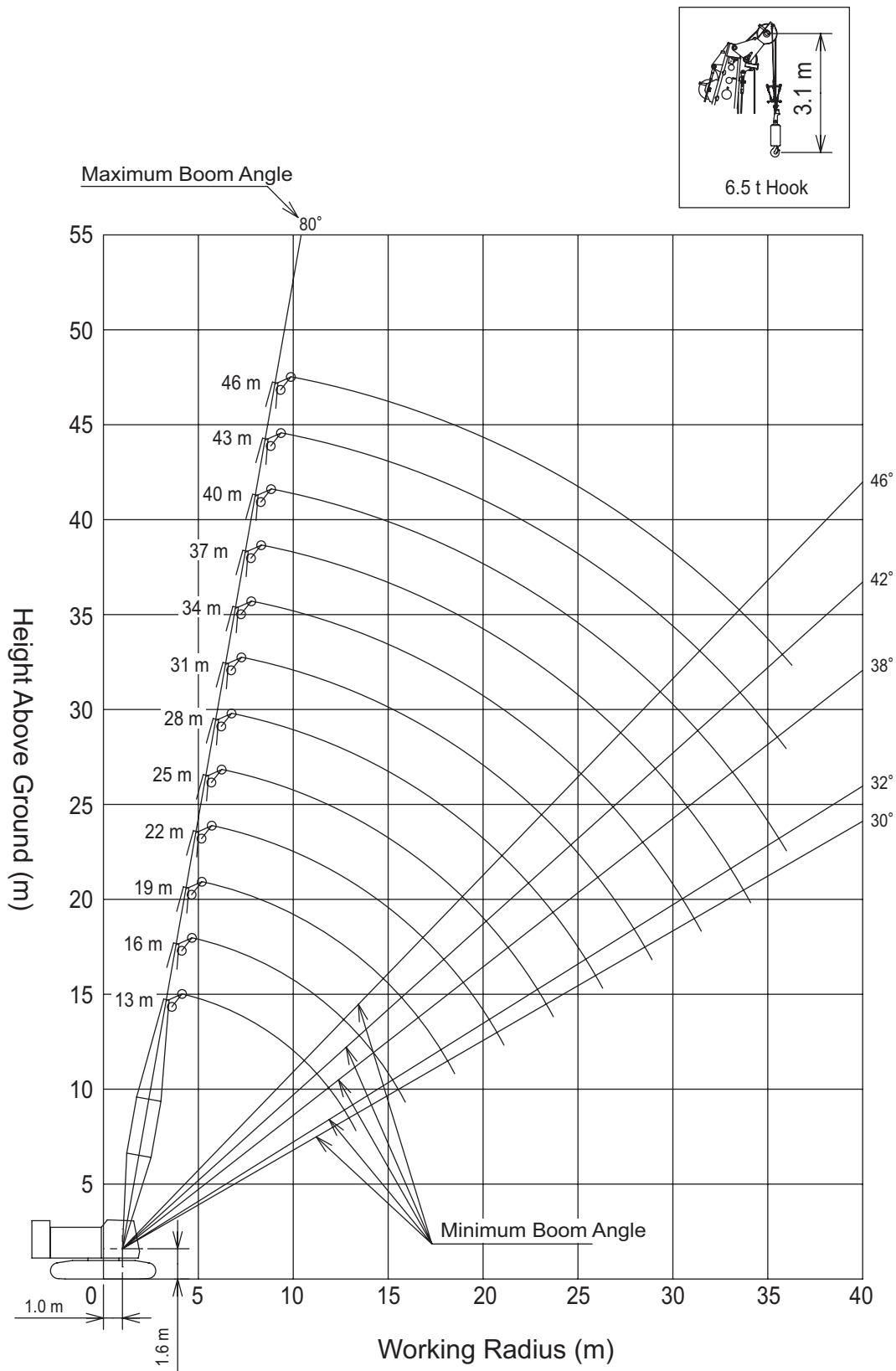

■ Crane Jib

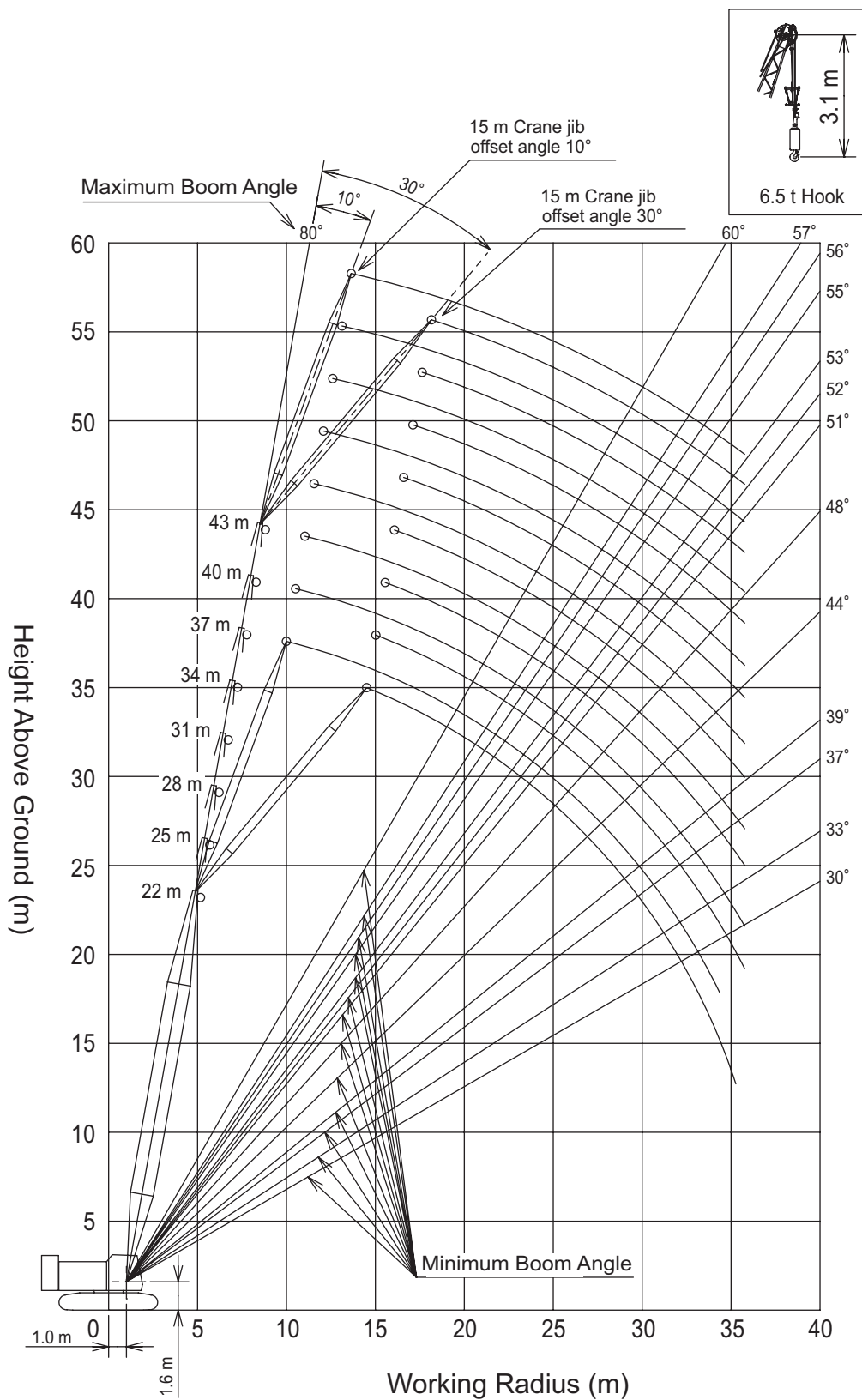

Gross Rated Load Table

■ Main Boom



Unit:t

Working Radius (m)	Boom Length (m)								Working Radius (m)
	10	13	16	19	22	25	28	31	
3		3.7 m x							3
3.5	55.00	55.00 t	4.4 m x						3.5
4	51.20	50.10	41.70 t						4
4.5	42.30	42.20	40.55						4.5
5	35.80	35.75	35.65	34.00					5
5.5	31.05	30.95	30.85	30.55	29.10	6.1 m x	6.7 m x		5.5
6	27.35	27.25	27.20	27.15	26.45	24.95 t	21.65 t	7.3 m x	6
7	22.05	21.95	21.85	21.85	21.75	21.50	20.70	19.10 t	7
8	18.45	18.30	18.25	18.25	18.10	18.05	18.00	17.35	8
9	15.30	15.70	15.60	15.55	15.45	15.40	15.30	15.25	9
10	9.8 m x	13.70	13.60	13.50	13.45	13.40	13.30	13.25	10
12	12.55 t	10.70	10.75	10.65	10.60	10.55	10.45	10.40	12
14		12.4 m x	8.80	8.75	8.65	8.60	8.50	8.45	14
16		9.90 t	15.0 m x	7.35	7.25	7.20	7.10	7.05	16
18			8.00 t	17.6 m x	6.25	6.15	6.05	6.00	18
20				6.50 t	5.45	5.35	5.25	5.15	20
22					20.2 m x	4.70	4.60	4.50	22
24					5.35 t	22.8 m x	4.05	3.95	24
26						4.50 t	25.4 m x	3.50	26
28							3.75 t	3.10	28

Unit:t

Working Radius (m)	Boom Length (m)						Working Radius (m)
	34	37	40	43	46	49	
6	7.8 m x						6
7	17.15 t	8.4 m x					7
8	16.70	15.40 t		9.6 m x			8
9	14.75	14.30	13.80	12.40 t	10.1 m x	10.7 m x	9
10	13.15	12.80	12.35	11.90	11.35 t	10.35 t	10
12	10.30	10.20	10.10	9.75	9.45	9.10	12
14	8.35	8.25	8.15	8.15	7.90	7.65	14
16	6.95	6.85	6.75	6.75	6.65	6.50	16
18	5.90	5.80	5.70	5.65	5.55	5.40	18
20	5.10	5.00	4.85	4.80	4.70	4.55	20
22	4.40	4.30	4.20	4.10	4.00	3.85	22
24	3.85	3.75	3.60	3.55	3.45	3.30	24
26	3.40	3.30	3.15	3.10	2.95	2.85	26
28	3.00	2.90	2.75	2.70	2.55	2.45	28
30	2.65	2.55	2.40	2.35	2.20	2.10	30
32	30.6 m x	2.25	2.15	2.05	1.95	1.80	32
34	2.55 t	33.2 m x	1.90	1.80	1.65	1.55	34
36		2.10 t	35.8 m x	1.55	1.45	1.35	36
38			1.70 t				38

- The rated loads are determined according to EN13000 rating on the condition that the machine is stationed on firm and level ground.
- The figures surrounded by bold lines are based on factors other than those which would cause a tipping condition.
- To calculate the maximum load that can actually be lifted, deduct weight of all lifting accessories, such as boom hook and jib hook, from figures shown above.
- Working radius is the horizontal distance from the swing center to the center of gravity of a lifted load.
- The counter weight is 18.6 t.
- Figures described as ○○ m x ○○ t in the tables indicate "working radius" m x "rated load" t.
- Be sure to fully extend the side frames before operating the machine.
- Correlation between the number of reeved lines, maximum rated loads, hook weights are shown in the table below.
- Be sure to attach the 55 t hook to the top boom when boom length is 10 m or 13 m.

Hook Capacity (t)	Hook Weight (t)	Maximum Rated Loads (t)								
		9 falls	8 falls	7 falls	6 falls	5 falls	4 falls	3 falls	2 falls	1 fall
55.0	0.85	55.00	52.00	45.50	39.00	32.50	26.00	19.50	13.00	-
30.0	0.36	-	-	-	-	30.00	26.00	19.50	13.00	-
15.0	0.32	-	-	-	-	-	-	15.00	13.00	-
6.5	0.18	-	-	-	-	-	-	-	-	6.50

■ Aux. Sheave



Unit:t

Working Radius (m)	Boom Length (m)								Working Radius (m)
	13	16	19	22	25	28	31	34	
4.7	6.50	5.2 m x 6.50 t							4.7
5	6.50	6.50	5.8 m x 6.50 t						5
5.5	6.50	6.50	6.50	6.4 m x 6.50 t					5.5
6	6.50	6.50	6.50	6.50			7.5 m x 6.50 t		6
7	6.50	6.50	6.50	6.50	6.50		8.1 m x 6.50 t	8.7 m x 6.50 t	7
8	6.50	6.50	6.50	6.50	6.50	6.50	6.50	6.50	8
9	6.50	6.50	6.50	6.50	6.50	6.50	6.50	6.50	9
10	6.50	6.50	6.50	6.50	6.50	6.50	6.50	6.50	10
12	6.50	6.50	6.50	6.50	6.50	6.50	6.50	6.50	12
14	13.5 m x 6.50 t	6.50	6.50	6.50	6.50	6.50	6.50	6.50	14
16	6.50	6.50	6.50	6.50	6.50	6.50	6.50	6.50	16
18		16.1 m x 6.50 t	6.25	6.10	6.05	5.95	5.90	5.80	18
20		6.50	18.7 m x 5.95 t	5.30	5.25	5.10	5.05	5.00	20
22				21.3 m x 4.85 t	4.55	4.45	4.35	4.30	22
24					23.9 m x 4.05 t	3.90	3.80	3.70	24
26						3.45	3.30	3.25	26
28						26.5 m x 3.35 t	2.90	2.85	28
30							29.1 m x 2.70 t	2.50	30
32								31.7 m x 2.25 t	32
34									34

Unit:t

Working Radius (m)	Boom Length (m)				Working Radius (m)
	37	40	43	46	
8	9.2 m x 6.50 t	9.8 m x 6.50 t			8
9	6.50	6.50	10.4 m x 6.50 t	10.9 m x 6.50 t	9
10	6.50	6.50	6.50	6.50	10
12	6.50	6.50	6.50	6.50	12
14	6.50	6.50	6.50	6.50	14
16	6.50	6.50	6.50	6.50	16
18	5.70	5.70	5.60	5.50	18
20	4.90	4.80	4.75	4.65	20
22	4.20	4.10	4.05	3.95	22
24	3.60	3.50	3.45	3.35	24
26	3.15	3.05	2.95	2.85	26
28	2.75	2.60	2.55	2.45	28
30	2.40	2.25	2.20	2.10	30
32	2.10	1.95	1.90	1.80	32
34	1.85	1.70	1.65	1.50	34
36	34.3 m x 1.80 t	1.50	1.40	1.30	36
38					38

1. The rated loads are determined according to EN13000 rating on the condition that the machine is stationed on firm and level ground.
2. The figures surrounded by bold lines are based on factors other than those which would cause a tipping condition.
3. To calculate the maximum load that can actually be lifted, deduct weight of all lifting accessories, such as boom hook and jib hook, from figures shown above.
4. Working radius is the horizontal distance from the swing center to the center of gravity of a lifted load.
5. The counter weight is 18.6 t.
6. Figures described as ○○ m x ○○ t in the tables indicate "working radius" m x "rated load" t.
7. Be sure to fully extend the side frames before operating the machine.
8. Hook mass are shown in the table below.

Hook Capacity (t)	Hook Weight (t)
55.0	0.85
30.0	0.36
15.0	0.32
6.5	0.18

■ Main Boom with Aux. Sheave



Unit:t

Working Radius (m)	Boom Length (m)								Working Radius (m)
	13	16	19	22	25	28	31	34	
3.7	54.70	4.4 m x							3.7
4	49.90	41.50 t							4
4.5	41.90	40.40							4.5
5	35.45	35.35	33.90						5
5.5	30.65	30.55	30.40	29.00	6.1 m x	6.7 m x			5.5
6	26.95	26.90	26.85	26.30	24.90 t	21.60 t	7.3 m x	7.8 m x	6
7	21.65	21.55	21.55	21.45	21.40	20.60	19.10 t	17.10 t	7
8	18.00	17.95	17.90	17.80	17.75	17.70	17.30	16.70	8
9	15.40	15.30	15.25	15.15	15.10	15.00	14.95	14.70	9
10	13.40	13.30	13.20	13.15	13.10	13.00	12.95	12.85	10
12	10.40	10.45	10.35	10.30	10.25	10.15	10.10	10.00	12
14	12.4 m x	8.50	8.45	8.35	8.30	8.20	8.15	8.05	14
16	9.60 t	15.0 m x	7.05	6.95	6.90	6.80	6.75	6.65	16
18		7.70 t	17.6 m x	5.95	5.85	5.75	5.70	5.60	18
20			6.20 t	5.15	5.05	4.95	4.85	4.80	20
22				20.2 m x	4.40	4.30	4.20	4.10	22
24				5.05 t	22.8 m x	3.75	3.70	3.60	24
26					4.20 t	25.4 m x	3.20	3.10	26
28						3.45 t	2.80	2.70	28
30								2.40	30
32								30.6 m x	32
34								2.30 t	34

Unit:t

Working Radius (m)	Boom Length (m)				Working Radius (m)
	37	40	43	46	
7	8.4 m x				7
8	15.40 t		9.6 m x		8
9	14.30	13.80	12.50 t	10.1 m x	9
10	12.70	12.40	12.00	11.40 t	10
12	9.90	9.80	9.70	9.40	12
14	7.95	7.85	7.85	7.75	14
16	6.55	6.45	6.45	6.35	16
18	5.50	5.40	5.35	5.30	18
20	4.70	4.60	4.55	4.45	20
22	4.00	3.90	3.90	3.80	22
24	3.50	3.40	3.35	3.25	24
26	3.00	2.90	2.90	2.80	26
28	2.60	2.50	2.50	2.40	28
30	2.30	2.20	2.10	2.00	30
32	2.00	1.90	1.80	1.70	32
34	33.2 m x	1.60	1.55	1.40	34
36	1.85 t	35.8 m x	1.30	1.20	36
38		1.40 t			38

1. The rated loads are determined according to EN13000 rating on the condition that the machine is stationed on firm and level ground.
2. The figures surrounded by bold lines are based on factors other than those which would cause a tipping condition.
3. To calculate the maximum load that can actually be lifted, deduct weight of all lifting accessories, such as boom hook and jib hook, from figures shown above.
4. Working radius is the horizontal distance from the swing center to the center of gravity of a lifted load.
5. The counter weight is 18.6 t.
6. Figures described as ○○ m x ○○ t in the tables indicate "working radius" m x "rated load" t.
7. Be sure to fully extend the side frames before operating the machine.
8. Correlation between the number of reeved lines, maximum rated loads, hook weights are shown in the table below.
9. Be sure to attach the 55 t hook to the top boom when boom length is 13 m.

Hook Capacity (t)	Hook Weight (t)	Maximum Rated Loads (t)								
		9 falls	8 falls	7 falls	6 falls	5 falls	4 falls	3 falls	2 falls	1 fall
55.0	0.85	55.00	52.00	45.50	39.00	32.50	26.00	19.50	13.00	-
30.0	0.36	-	-	-	-	30.00	26.00	19.50	13.00	-
15.0	0.32	-	-	-	-	-	-	15.00	13.00	-
6.5	0.18	-	-	-	-	-	-	-	-	6.50

■Crane Jib



Unit:t

Boom Length (m)	22								Boom Length (m)
Jib Length (m)	6		9		12		15		Jib Length (m)
Offset Angle (°)	10	30	10	30	10	30	10	30	Offset Angle (°)
Working Radius (m)									Working Radius (m)
7	8.1 m x								7
8	6.50 t								8
9	6.50	9.9 m x 6.50 t	9.3 m x 5.00 t						9
10	6.50	6.50	5.00	11.9 m x 5.00 t	10.4 m x 4.10 t		11.5 m x 3.30 t		10
12	6.50	6.50	5.00	5.00	4.10	13.9 m x 4.10 t	3.30	15.9 m x 3.30 t	12
14	6.50	6.50	5.00	5.00	4.10	4.10	3.30	3.30 t	14
16	6.50	6.50	5.00	5.00	4.10	4.10	3.30	3.30	16
18	6.15	6.25	5.00	5.00	4.10	4.00	3.30	3.25	18
20	5.30	5.40	5.00	4.85	4.10	3.75	3.30	3.05	20
22	4.65	4.70	4.70	4.55	4.10	3.55	3.30	2.85	22
24	4.10	4.15	4.20	4.25	4.10	3.35	3.30	2.70	24
26	3.45	3.50	3.75	3.80	3.80	3.20	3.30	2.55	26
28	26.1 m x 3.45 t	26.5 m x 3.35 t	3.15	3.40	3.40	3.05	3.10	2.45	28
30			28.9 m x 3.00 t	29.5 m x 2.85 t	2.90	2.95	2.85	2.30	30
32					31.8 m x 2.55 t	2.65	2.65	2.25	32
34						32.5 m x 2.50 t	2.40	2.20	34
36							34.6 m x 2.05 t	35.5 m x 2.10 t	36
38									38

Unit:t

Boom Length (m)	25								Boom Length (m)
Jib Length (m)	6		9		12		15		Jib Length (m)
Offset Angle (°)	10	30	10	30	10	30	10	30	Offset Angle (°)
Working Radius (m)									Working Radius (m)
7	8.8 m x								7
8	6.50 t								8
9	6.50	10.5 m x 6.50 t	9.9 m x 5.00 t						9
10	6.50	6.50	5.00	12.5 m x 5.00 t	11.0 m x 4.10 t		12.1 m x 3.30 t		10
12	6.50	6.50	5.00	5.00	4.10	14.5 m x 4.10 t	3.30		12
14	6.50	6.50	5.00	5.00	4.10	4.10 t	3.30	16.5 m x 3.30 t	14
16	6.50	6.50	5.00	5.00	4.10	4.10	3.30	3.30 t	16
18	6.05	6.15	5.00	5.00	4.10	4.10	3.30	3.30	18
20	5.25	5.35	5.00	5.00	4.10	3.85	3.30	3.15	20
22	4.55	4.65	4.65	4.75	4.10	3.65	3.30	2.95	22
24	4.00	4.10	4.10	4.20	3.90	3.45	3.30	2.80	24
26	3.55	3.60	3.65	3.70	3.70	3.30	3.30	2.65	26
28	3.00	3.05	3.25	3.30	3.30	3.20	3.15	2.55	28
30	28.7 m x 2.80 t	29.1 m x 2.75 t	2.75	2.95	2.95	3.05	3.00	2.45	30
32			31.5 m x 2.45 t	2.40	2.55	2.75	2.70	2.35	32
34				32.1 m x 2.40 t	2.20	2.30	2.45	2.25	34
36					34.7 m x 1.90 t	35.1 m x 1.95 t	2.05	2.15	36
38									38

1. The rated loads are determined according to EN13000 rating on the condition that the machine is stationed on firm and level ground.
2. The figures surrounded by bold lines are based on factors other than those which would cause a tipping condition.
3. To calculate the maximum load that can actually be lifted, deduct weight of all lifting accessories, such as boom hook and jib hook, from figures shown above.
4. Working radius is the horizontal distance from the swing center to the center of gravity of a lifted load.
5. The counter weight is 18.6 t.
6. Figures described as ○○ m x ○○ t in the tables indicate "working radius" m x "rated load" t.
7. Be sure to fully extend the side frames before operating the machine.
8. Hook mass are shown in the table below.

Hook Capacity (t)	Hook Weight (t)
55.0	0.85
30.0	0.36
15.0	0.32
6.5	0.18

■Crane Jib



Unit:t

Boom Length (m)	28								Boom Length (m)
Jib Length (m)	6		9		12		15		Jib Length (m)
Offset Angle (°)	10	30	10	30	10	30	10	30	Offset Angle (°)
Working Radius (m)									Working Radius (m)
8	9.4 m x								8
9	6.50 t	11.1 m x	10.5 m x		11.6 m x				9
10	6.50	6.50 t	5.00 t	13.2 m x	4.10 t		12.7 m x		10
12	6.50	6.50	5.00	5.00 t	4.10	15.2 m x	3.30 t		12
14	6.50	6.50	5.00	5.00	4.10	4.10 t	3.30	17.2 m x	14
16	6.50	6.50	5.00	5.00	4.10	4.10	3.30	3.30 t	16
18	5.95	6.10	5.00	5.00	4.10	4.10	3.30	3.30	18
20	5.10	5.25	5.00	5.00	4.10	4.00	3.30	3.20	20
22	4.45	4.55	4.55	4.70	4.10	3.75	3.30	3.05	22
24	3.90	4.00	4.00	4.10	4.05	3.60	3.30	2.90	24
26	3.45	3.50	3.55	3.65	3.60	3.40	3.30	2.75	26
28	3.05	3.10	3.15	3.20	3.20	3.20	3.25	2.60	28
30	2.60	2.60	2.80	2.85	2.85	2.95	2.90	2.50	30
32	31.3 m x	31.7 m x	2.35	2.40	2.55	2.65	2.60	2.40	32
34	2.30 t	2.30 t	2.05	2.10	2.20	2.35	2.35	2.30	34
36			34.1 m x	34.7 m x	1.85	2.10	2.05	2.20	36
38			2.00 t	2.00 t					38

Unit:t

Boom Length (m)	31								Boom Length (m)
Jib Length (m)	6		9		12		15		Jib Length (m)
Offset Angle (°)	10	30	10	30	10	30	10	30	Offset Angle (°)
Working Radius (m)									Working Radius (m)
9		11.8 m x	11.1 m x						9
10	6.50	6.50 t	5.00 t	13.8 m x	12.2 m x		13.4 m x		10
12	6.50	6.50	5.00	5.00 t	4.10 t	15.8 m x	3.30 t		12
14	6.50	6.50	5.00	5.00	4.10	4.10 t	3.30	17.8 m x	14
16	6.50	6.50	5.00	5.00	4.10	4.10	3.30	3.30 t	16
18	5.90	6.05	5.00	5.00	4.10	4.10	3.30	3.30	18
20	5.05	5.20	5.00	5.00	4.10	4.10	3.30	3.30	20
22	4.40	4.50	4.45	4.65	4.10	3.90	3.30	3.10	22
24	3.80	3.90	3.90	4.05	3.95	3.70	3.30	2.95	24
26	3.35	3.45	3.45	3.55	3.50	3.45	3.30	2.80	26
28	2.95	3.05	3.05	3.15	3.10	3.25	3.15	2.70	28
30	2.50	2.55	2.70	2.80	2.75	2.90	2.80	2.60	30
32	2.25	2.25	2.30	2.40	2.45	2.55	2.50	2.50	32
34	33.9 m x	1.95	2.05	2.10	2.15	2.25	2.20	2.35	34
36	1.90 t	34.3 m x	1.80	1.80	1.95	2.00	1.95	2.10	36
38		1.90 t							38

*For notes about the table above, refer to page 17.

■Crane Jib



Unit:t

Boom Length (m)	34								Boom Length (m)
Jib Length (m)	6		9		12		15		Jib Length (m)
Offset Angle (°)	10	30	10	30	10	30	10	30	Offset Angle (°)
Working Radius (m)									Working Radius (m)
9	10.6 m x		11.7 m x						9
10	6.50 t	12.4 m x	5.00 t		12.9 m x				10
12	6.50	6.50 t	5.00	14.4 m x	4.10 t				12
14	6.50	6.50	5.00	5.00 t	4.10	16.4 m x	3.30		14
16	6.45	6.50	5.00	5.00	4.10	4.10 t	3.30	18.4 m x	16
18	5.80	5.95	5.00	5.00	4.10	4.10	3.30	3.30 t	18
20	4.95	5.10	5.00	5.00	4.10	4.10	3.30	3.30	20
22	4.30	4.40	4.40	4.55	4.10	3.95	3.30	3.20	22
24	3.75	3.85	3.80	4.00	3.90	3.80	3.30	3.05	24
26	3.30	3.35	3.35	3.50	3.45	3.60	3.30	2.90	26
28	2.90	2.95	2.95	3.10	3.05	3.20	3.10	2.75	28
30	2.55	2.60	2.60	2.70	2.65	2.80	2.70	2.65	30
32	2.10	2.15	2.30	2.40	2.35	2.50	2.40	2.50	32
34	1.85	1.85	1.90	2.10	2.10	2.20	2.10	2.30	34
36	34.5 m x	35.0 m x	1.50	1.85	1.85	1.95	1.90	2.00	36
38	1.75 t	1.70 t							38

Unit:t

Boom Length (m)	37								Boom Length (m)
Jib Length (m)	6		9		12		15		Jib Length (m)
Offset Angle (°)	10	30	10	30	10	30	10	30	Offset Angle (°)
Working Radius (m)									Working Radius (m)
9	11.2 m x								9
10	6.50 t	13.0 m x	12.4 m x		13.5 m x				10
12	6.50	6.50 t	5.00 t	15.0 m x	4.10 t		14.6 m x		12
14	6.50	6.50	5.00	5.00 t	4.10	17.0m x	3.30 t		14
16	6.30	6.50	5.00	5.00	4.10	4.10 t	3.30	19.0 m x	16
18	5.70	5.90	5.00	5.00	4.10	4.10	3.30	3.30 t	18
20	4.85	5.00	4.95	5.00	4.10	4.10	3.30	3.30	20
22	4.20	4.30	4.30	4.50	4.10	4.05	3.30	3.25	22
24	3.65	3.75	3.70	3.90	3.80	3.80	3.30	3.10	24
26	3.20	3.25	3.25	3.40	3.35	3.55	3.15	2.95	26
28	2.80	2.85	2.85	3.00	2.90	3.10	3.00	2.85	28
30	2.45	2.50	2.50	2.60	2.55	2.75	2.60	2.65	30
32	2.10	2.20	2.20	2.30	2.25	2.40	2.30	2.45	32
34	1.70	1.75	1.90	2.00	2.00	2.10	2.00	2.20	34
36	34.5 m x	35.2 m x	1.65	1.75	1.75	1.85	1.80	1.95	36
38	1.60 t	1.45 t							38

*For notes about the table above, refer to page 17.

■Crane Jib



Unit:t

Boom Length (m)	40								Boom Length (m)
Jib Length (m)	6		9		12		15		Jib Length (m)
Offset Angle (°)	10	30	10	30	10	30	10	30	Offset Angle (°)
Working Radius (m)									Working Radius (m)
9	11.9 m x								9
10	6.50 t								10
12	6.50	13.6 m x	13.0 m x		15.6 m x	14.1 m x		15.2 m x	12
14	6.50	6.50 t	5.00 t		5.00 t	4.10 t		3.30 t	14
16	6.50	6.50	5.00		5.00	4.10	17.7 m x	3.30	19.7 m x
18	5.65	5.85	5.00		5.00	4.10	4.10	3.30	3.30 t
20	4.80	5.00	4.90		5.00	4.10	4.10	3.30	3.30
22	4.15	4.30	4.25	4.45	4.10	4.10	3.30	3.30	22
24	3.55	3.70	3.65	3.85	3.75	4.00	3.30	3.15	24
26	3.10	3.20	3.15	3.35	3.25	3.50	3.30	3.00	26
28	2.65	2.75	2.75	2.90	2.80	3.05	2.85	2.90	28
30	2.30	2.40	2.40	2.50	2.45	2.65	2.50	2.70	30
32	2.00	2.10	2.05	2.20	2.15	2.30	2.20	2.40	32
34	1.75	1.80	1.80	1.90	1.85	2.00	1.90	2.10	34
36	1.50	1.55	1.55	1.65	1.60	1.75	1.65	1.85	36

Unit:t

Boom Length (m)	43								Boom Length (m)
Jib Length (m)	6		9		12		15		Jib Length (m)
Offset Angle (°)	10	30	10	30	10	30	10	30	Offset Angle (°)
Working Radius (m)									Working Radius (m)
10	12.5 m x		13.6 m x						10
12	6.50 t		5.00 t						12
14	6.50	14.3 m x	5.00		16.3 m x	4.10 t		15.9 m x	14
16	6.50	6.50 t	5.00		5.00 t	4.10	18.3 m x	3.30	16
18	5.60	5.75	5.00		5.00	4.10	4.10 t	3.30	20.3 m x
20	4.70	4.90	4.80		5.00	4.10	4.10	3.30	3.30 t
22	4.05	4.20	4.15	4.35	4.10	4.10	3.30	3.30	22
24	3.50	3.60	3.60	3.80	3.65	3.90	3.30	3.20	24
26	3.05	3.15	3.10	3.30	3.15	3.40	3.25	3.05	26
28	2.60	2.70	2.70	2.85	2.75	3.00	2.80	2.90	28
30	2.25	2.35	2.30	2.45	2.40	2.60	2.45	2.70	30
32	1.90	2.00	2.00	2.15	2.05	2.25	2.10	2.35	32
34	1.65	1.70	1.70	1.85	1.80	1.95	1.85	2.05	34
36	1.40	1.45	1.45	1.60	1.55	1.70	1.60	1.80	36

*For notes about the table above, refer to page 17.

■ Main Boom with Crane Jib



Unit:t

Boom Length (m)	22								Boom Length (m)
Jib Length (m)	6		9		12		15		Jib Length (m)
Offset Angle (°)	10	30	10	30	10	30	10	30	Offset Angle (°)
Working Radius (m)									Working Radius (m)
5.5	28.60	28.45	28.35	28.10	28.10	27.70	27.80	27.25	5.5
6	25.95	25.80	25.70	25.45	25.45	25.10	25.15	24.65	6
7	21.00	21.00	20.85	20.85	20.70	20.70	20.55	20.55	7
8	17.35	17.35	17.20	17.20	17.05	17.05	16.90	16.90	8
9	14.70	14.70	14.55	14.55	14.40	14.40	14.25	14.25	9
10	12.70	12.70	12.55	12.55	12.40	12.40	12.25	12.25	10
12	9.85	9.85	9.70	9.70	9.55	9.55	9.40	9.40	12
14	7.90	7.90	7.75	7.75	7.60	7.60	7.45	7.45	14
16	6.50	6.50	6.35	6.35	6.20	6.20	6.05	6.05	16
18	5.50	5.50	5.35	5.35	5.20	5.20	5.05	5.05	18
20	4.70	4.70	4.55	4.55	4.40	4.40	4.25	4.25	20
22	20.2 m x 4.60 t	20.2 m x 4.60 t	20.2 m x 4.45 t	20.2 m x 4.45 t	20.2 m x 4.30 t	20.2 m x 4.30 t	20.2 m x 4.15 t	20.2 m x 4.15 t	22
24									24

Unit:t

Boom Length (m)	25								Boom Length (m)
Jib Length (m)	6		9		12		15		Jib Length (m)
Offset Angle (°)	10	30	10	30	10	30	10	30	Offset Angle (°)
Working Radius (m)									Working Radius (m)
5.5	6.1 m x 24.50 t	6.1 m x 24.30 t	6.1 m x 24.20 t	6.1 m x 24.00 t	6.1 m x 24.00 t	6.1 m x 23.60 t	6.1 m x 23.70 t	6.1 m x 23.20 t	5.5
6									6
7	20.95	20.90	20.80	20.60	20.55	20.25	20.30	19.90	7
8	17.30	17.30	17.15	17.15	17.00	17.00	16.85	16.85	8
9	14.65	14.65	14.50	14.50	14.35	14.35	14.20	14.20	9
10	12.65	12.65	12.50	12.50	12.35	12.35	12.20	12.20	10
12	9.80	9.80	9.65	9.65	9.50	9.50	9.35	9.35	12
14	7.85	7.85	7.70	7.70	7.55	7.55	7.40	7.40	14
16	6.45	6.45	6.30	6.30	6.15	6.15	6.00	6.00	16
18	5.40	5.40	5.25	5.25	5.10	5.10	4.95	4.95	18
20	4.60	4.60	4.45	4.45	4.30	4.30	4.15	4.15	20
22	3.95	3.95	3.80	3.80	3.65	3.65	3.50	3.50	22
24	22.8 m x 3.75 t	22.8 m x 3.75 t	22.8 m x 3.60 t	22.8 m x 3.60 t	22.8 m x 3.45 t	22.8 m x 3.45 t	22.8 m x 3.30 t	22.8 m x 3.30 t	24
26									26

1. The rated loads are determined according to EN13000 rating on the condition that the machine is stationed on firm and level ground.
2. To calculate the maximum load that can actually be lifted, deduct weight of all lifting accessories, such as boom hook and jib hook, from figures shown above.
3. Working radius is the horizontal distance from the swing center to the center of gravity of a lifted load.
4. The counter weight is 18.6 t.
5. Figures described as ○○ m x ○○ t in the tables indicate "working radius" m x "rated load" t.
6. Be sure to fully extend the side frames before operating the machine.
7. Correlation between the number of reeved lines, maximum rated loads, hook weights are shown in the table below.

Hook Capacity (t)	Hook Weight (t)	Maximum Rated Loads (t)				
		5 falls	4 falls	3 falls	2 falls	1 fall
30.0	0.36	30.00	26.00	19.50	13.00	-
15.0	0.32	-	-	15.00	13.00	-
6.5	0.18	-	-	-	-	6.50

■ Main Boom with Crane Jib



Unit:t

Boom Length (m)	28								Boom Length (m)
Jib Length (m)	6		9		12		15		Jib Length (m)
Offset Angle (°)	10	30	10	30	10	30	10	30	Offset Angle (°)
Working Radius (m)									Working Radius (m)
5.5	6.7 m x	6.7 m x	6.7 m x	6.7 m x	6.7 m x	6.7 m x	6.7 m x	6.7 m x	5.5
6	21.20 t	21.10 t	21.00 t	20.80 t	20.80 t	20.50 t	20.50 t	20.10 t	6
7	20.30	20.15	20.05	19.85	19.80	19.50	19.55	19.15	7
8	17.25	17.25	17.10	17.10	16.95	16.80	16.80	16.50	8
9	14.55	14.55	14.40	14.40	14.25	14.25	14.10	14.10	9
10	12.55	12.55	12.40	12.40	12.25	12.25	12.10	12.10	10
12	9.70	9.70	9.55	9.55	9.40	9.40	9.25	9.25	12
14	7.75	7.75	7.60	7.60	7.45	7.45	7.30	7.30	14
16	6.35	6.35	6.20	6.20	6.05	6.05	5.90	5.90	16
18	5.30	5.30	5.15	5.15	5.00	5.00	4.85	4.85	18
20	4.50	4.50	4.35	4.35	4.20	4.20	4.05	4.05	20
22	3.85	3.85	3.70	3.70	3.55	3.55	3.40	3.40	22
24	3.30	3.30	3.15	3.15	3.00	3.00	2.85	2.85	24
26	25.4 m x	25.4 m x	25.4 m x	25.4 m x	25.4 m x	25.4 m x	25.4 m x	25.4 m x	26
28	3.00 t	3.00 t	2.85 t	2.85 t	2.70 t	2.70 t	2.55 t	2.55 t	28

Unit:t

Boom Length (m)	31								Boom Length (m)
Jib Length (m)	6		9		12		15		Jib Length (m)
Offset Angle (°)	10	30	10	30	10	30	10	30	Offset Angle (°)
Working Radius (m)									Working Radius (m)
6	7.3 m x	7.3 m x	7.3 m x	7.3 m x	7.3 m x	7.3 m x	7.3 m x	7.3 m x	6
7	18.70 t	18.60 t	18.50 t	18.30 t	18.30 t	18.00 t	18.00 t	17.70 t	7
8	16.95	16.85	16.75	16.55	16.50	16.25	16.25	15.95	8
9	14.50	14.50	14.35	14.35	14.20	14.20	14.05	13.90	9
10	12.50	12.50	12.35	12.35	12.20	12.20	12.05	12.05	10
12	9.65	9.65	9.50	9.50	9.35	9.35	9.20	9.20	12
14	7.70	7.70	7.55	7.55	7.40	7.40	7.25	7.25	14
16	6.30	6.30	6.15	6.15	6.00	6.00	5.85	5.85	16
18	5.25	5.25	5.10	5.10	4.95	4.95	4.80	4.80	18
20	4.40	4.40	4.25	4.25	4.10	4.10	3.95	3.95	20
22	3.75	3.75	3.60	3.60	3.45	3.45	3.30	3.30	22
24	3.25	3.25	3.10	3.10	2.95	2.95	2.80	2.80	24
26	2.80	2.80	2.65	2.65	2.50	2.50	2.35	2.35	26
28	2.40	2.40	2.25	2.25	2.10	2.10	1.95	1.95	28

*For notes about the table above, refer to page 21.

■ Main Boom with Crane Jib



Unit:t

Boom Length (m)	34								Boom Length (m)
Jib Length (m)	6		9		12		15		Jib Length (m)
Offset Angle (°)	10	30	10	30	10	30	10	30	Offset Angle (°)
Working Radius (m)									Working Radius (m)
6	7.8 m x	7.8 m x	7.8 m x	7.8 m x	7.8 m x	7.8 m x	7.8 m x	7.8 m x	6
7	16.80 t	16.70 t	16.60 t	16.40 t	16.40 t	16.10 t	16.10 t	15.80 t	7
8	16.35	16.25	16.15	15.95	15.95	15.70	15.70	15.35	8
9	14.40	14.30	14.20	14.05	14.00	13.75	13.75	13.45	9
10	12.40	12.40	12.25	12.25	12.10	12.10	11.95	11.90	10
12	9.55	9.55	9.40	9.40	9.25	9.25	9.10	9.10	12
14	7.60	7.60	7.45	7.45	7.30	7.30	7.15	7.15	14
16	6.20	6.20	6.05	6.05	5.90	5.90	5.75	5.75	16
18	5.15	5.15	5.00	5.00	4.85	4.85	4.70	4.70	18
20	4.35	4.35	4.20	4.20	4.05	4.05	3.90	3.90	20
22	3.65	3.65	3.50	3.50	3.35	3.35	3.20	3.20	22
24	3.15	3.15	3.00	3.00	2.85	2.85	2.70	2.70	24
26	2.70	2.70	2.55	2.55	2.40	2.40	2.25	2.25	26
28	2.30	2.30	2.15	2.15	2.00	2.00	1.85	1.85	28
30	2.00	2.00	1.85	1.85	1.70	1.70	1.55	1.55	30
32	30.6 m x	30.6 m x	30.6 m x	30.6 m x	30.6 m x	30.6 m x	30.6 m x	30.6 m x	32
34	1.90 t	1.90 t	1.75 t	1.75 t	1.60 t	1.60 t	1.45 t	1.45 t	34

Unit:t

Boom Length (m)	37								Boom Length (m)
Jib Length (m)	6		9		12		15		Jib Length (m)
Offset Angle (°)	10	30	10	30	10	30	10	30	Offset Angle (°)
Working Radius (m)									Working Radius (m)
7	8.4 m x	8.4 m x	8.4 m x	8.4 m x	8.4 m x	8.4 m x	8.4 m x	8.4 m x	7
8	15.00 t	14.90 t	14.80 t	14.70 t	14.60 t	14.40 t	14.40 t	14.10 t	8
9	13.95	13.85	13.75	13.60	13.55	13.30	13.35	13.05	9
10	12.35	12.30	12.20	12.10	12.00	11.80	11.80	11.55	10
12	9.45	9.45	9.30	9.30	9.15	9.15	9.00	9.00	12
14	7.50	7.50	7.35	7.35	7.20	7.20	7.05	7.05	14
16	6.10	6.10	5.95	5.95	5.80	5.80	5.65	5.65	16
18	5.05	5.05	4.90	4.90	4.75	4.75	4.60	4.60	18
20	4.25	4.25	4.10	4.10	3.95	3.95	3.80	3.80	20
22	3.55	3.55	3.40	3.40	3.25	3.25	3.10	3.10	22
24	3.05	3.05	2.90	2.90	2.75	2.75	2.60	2.60	24
26	2.60	2.60	2.45	2.45	2.30	2.30	2.15	2.15	26
28	2.20	2.20	2.05	2.05	1.90	1.90	1.75	1.75	28
30	1.90	1.90	1.75	1.75	1.60	1.60	1.45	1.45	30
32	1.60	1.60	1.45	1.45	1.30	1.30			32
34	33.2 m x	33.2 m x	33.2 m x	33.2 m x					34
36	1.40 t	1.40 t	1.25 t	1.25 t					36

*For notes about the table above, refer to page 21.

■ Main Boom with Crane Jib



Unit:t

Boom Length (m)	40								Boom Length (m)
Jib Length (m)	6		9		12		15		Jib Length (m)
Offset Angle (°)	10	30	10	30	10	30	10	30	Offset Angle (°)
Working Radius (m)									Working Radius (m)
9	13.50	13.40	13.30	13.10	13.10	12.90	12.90	12.60	9
10	12.05	11.95	11.85	11.70	11.65	11.45	11.45	11.15	10
12	9.35	9.35	9.20	9.20	9.05	9.05	8.90	8.90	12
14	7.40	7.40	7.25	7.25	7.10	7.10	6.95	6.95	14
16	6.00	6.00	5.85	5.85	5.70	5.70	5.55	5.55	16
18	4.95	4.95	4.80	4.80	4.65	4.65	4.50	4.50	18
20	4.15	4.15	4.00	4.00	3.85	3.85	3.70	3.70	20
22	3.45	3.45	3.30	3.30	3.15	3.15	3.00	3.00	22
24	2.95	2.95	2.80	2.80	2.65	2.65	2.50	2.50	24
26	2.50	2.50	2.35	2.35	2.20	2.20	2.05	2.05	26
28	2.10	2.10	1.95	1.95	1.80	1.80	1.65	1.65	28
30	1.75	1.75	1.60	1.60	1.45	1.45	1.30	1.30	30
32	1.45	1.45	1.30	1.30					32
34	1.20	1.20							34

Unit:t

Boom Length (m)	43								Boom Length (m)
Jib Length (m)	6		9		12		15		Jib Length (m)
Offset Angle (°)	10	30	10	30	10	30	10	30	Offset Angle (°)
Working Radius (m)									Working Radius (m)
8	9.6 m x	9.6 m x	9.6 m x	9.6 m x	9.6 m x	9.6 m x	9.6 m x	9.6 m x	8
9	12.10 t	12.00 t	11.90 t	11.80 t	11.80 t	11.50 t	11.50 t	11.30 t	9
10	11.65	11.55	11.45	11.30	11.25	11.05	11.05	10.80	10
12	9.35	9.35	9.20	9.15	9.05	8.90	8.85	8.65	12
14	7.40	7.40	7.25	7.25	7.10	7.10	6.95	6.95	14
16	6.00	6.00	5.85	5.85	5.70	5.70	5.55	5.55	16
18	4.90	4.90	4.75	4.75	4.60	4.60	4.45	4.45	18
20	4.10	4.10	3.95	3.95	3.80	3.80	3.65	3.65	20
22	3.45	3.45	3.30	3.30	3.15	3.15	3.00	3.00	22
24	2.90	2.90	2.75	2.75	2.60	2.60	2.45	2.45	24
26	2.45	2.45	2.30	2.30	2.15	2.15	2.00	2.00	26
28	2.05	2.05	1.90	1.90	1.75	1.75	1.60	1.60	28
30	1.70	1.70	1.55	1.55	1.40	1.40	1.25	1.25	30
32	1.35	1.35	1.20	1.20					32

*For notes about the table above, refer to page 21.

Clamshell Specifications

Dimensions and Specifications

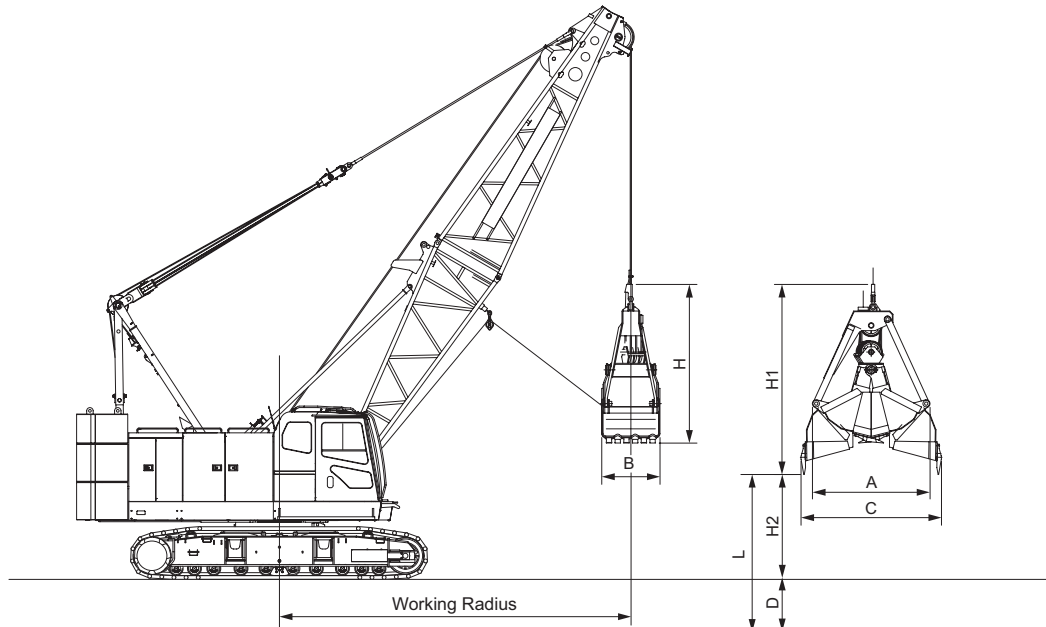

Working Ranges

Boom Length	m	10				13				16				19					
Boom Angle	°	35	45	55	65	35	45	55	65	35	45	55	65	35	45	55	65		
Working Radius	m	9.6	8.5	7.3	5.8	12.1	10.7	9.0	7.0	14.5	12.8	10.7	8.3	17.0	14.9	12.4	9.6		
Gross Rated Load	t	6.00	6.00	6.00	6.00	6.00	6.00	6.00	6.00	6.00	6.00	6.00	6.00	6.00	6.00	6.00	6.00		
0.8 m ³ Bucket	Lift L (D + H2)	m	Hydraulic	38.0	39.3	40.5	41.4	39.7	41.5	43.0	44.1	41.4	43.6	45.4	46.8	43.1	45.7	47.9	49.6
	Max. Digging Depth D	m	Hydraulic	36															
1.0 m ³ Bucket	Bucket Dumping Height H2	m		2.0	3.3	4.5	5.4	3.7	5.5	7.0	8.1	5.4	7.6	9.4	10.8	7.1	9.7	11.9	13.6
	Lift L (D + H2)	m	Hydraulic	37.8	39.1	40.3	41.2	39.5	41.3	42.8	43.9	41.2	43.4	45.2	46.6	42.6	45.5	47.7	49.4
	Max. Digging Depth D	m	Hydraulic	36															
1.2 m ³ Bucket	Bucket Dumping Height H2	m		1.8	3.1	4.3	5.2	3.5	5.3	6.8	7.9	5.2	7.4	9.2	10.6	6.6	9.5	11.7	13.4
	Lift L (D + H2)	m	Hydraulic	37.6	38.9	40.1	41.0	39.3	41.1	42.6	43.7	41.0	43.2	45.0	46.4	42.7	45.3	47.5	49.2
	Max. Digging Depth D	m	Hydraulic	36															
	Bucket Dumping Height H2	m		1.6	2.9	4.1	5.0	3.3	5.1	6.6	7.7	5.0	7.2	9.0	10.4	6.7	9.3	11.5	13.2

Specifications

Clamshell Specifications		
Bucket Capacity	m ³	0.8/1.0/1.2
Allowed Maximum Gross Weight for Clamshell Bucket and Captured Load Combined	t	6.0
Boom Length	m	10 to 19
Maximum Digging Depth	m	36
Support Wire Rope Speed *	m/min	74
Opening/Closing Wire Rope Speed *	m/min	74
Boom Hoist Drum Wire Rope Speed (Raise) *	m/min	60
Boom Hoist Drum Wire Rope Speed (Lower) *	m/min	60
Ground Contact Pressure	kPa (kgf/cm ²)	75.1 (0.77) (w/ Basic Boom, 1.2 m ³ Clamshell Bucket)
Overall Operating Weight	t	Approximately 54.8 (w/ Basic Boom, 1.2 m ³ Clamshell Bucket)

Note :

- Speeds marked with "*" may vary depending on load applied.
- SI units are used for specifications. In parenthesis, conventional units are also indicated.
- Specifications other than those shown above are the same as those shown in the crane specifications section.

Clamshell Bucket

Capacity (m ³)	Weight (t)	A (mm)	B (mm)	C (mm)	H (mm)	H1 (mm)
0.8	2.0	1880	970	2230	2270	2980
1.0	2.45	2020	1070	2430	2430	3150
1.2 (Lightweight Type)	2.4	2000	1160	2650	2600	3240

Gross Rated Load Table

Working Radius (m)	Boom Length (m)			
	10	13	16	19
3.7	6.00			
4.0	6.00	6.00		
4.5	6.00	6.00	4.6 m × 6.00 t	
5.0	6.00	6.00	6.00	5.2 m × 6.00 t
5.5	6.00	6.00	6.00	6.00
6.0	6.00	6.00	6.00	6.00
7.0	6.00	6.00	6.00	6.00
8.0	6.00	6.00	6.00	6.00
9.0	6.00	6.00	6.00	6.00
10.0	6.00	6.00	6.00	6.00
12.0		12.6 m × 6.00 t	6.00	6.00
14.0			6.00	6.00
16.0			15.2 m × 6.00 t	6.00
17.8				5.50

1. Working radius is the horizontal distance from the swing center to the center of gravity of a lifted load.
2. The rated loads for clamshell do not exceed 90% of those for crane.
3. The rated loads shown are upper limits determined by the following equation. Please select a bucket in such a manner that its rated load does not exceed the rated load shown above, according to kinds of the loads handled.
Rated load = Bucket capacity (m³) × Specific gravity of load (t/m³) + Bucket weight (t)
4. Even if using different capacities of the bucket according to the kinds of load, do not exceed the rated load.
5. Be sure to fully extend the side frames before operating the machine.
6. The counter weight is 18.6 t.

Weights and Dimensions of Disassembled Units

Weights and Dimensions List

Comply with the regulations when transporting.
"Weight" refers to the mass of each single unit.

Weights and Dimensions of Disassembled Units

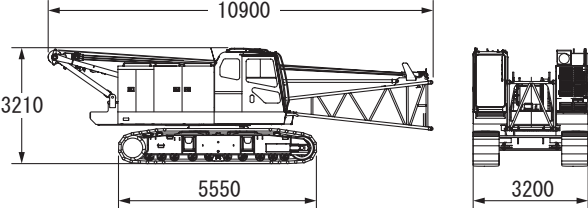
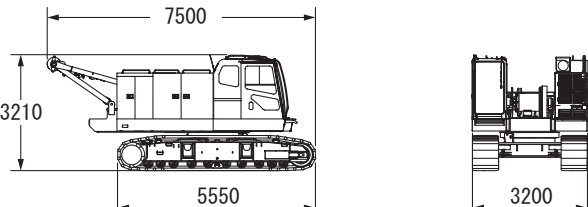
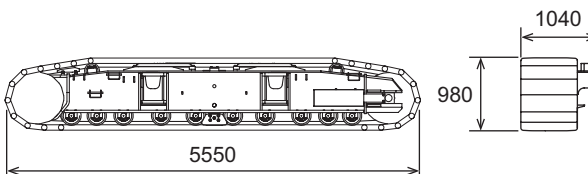
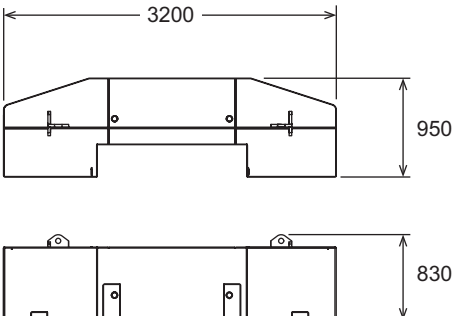
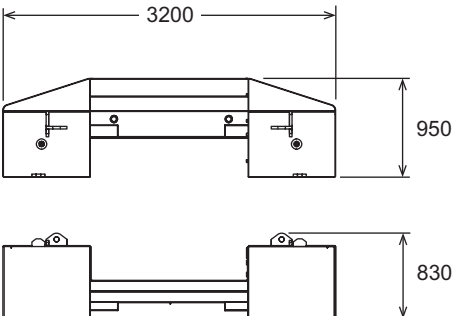
Description	Qty	Dimensions (mm)	Weight (kg)
Base Crane with: Boom Base Front Winch Wire Rope Boom Hoist Drum Wire Rope Crawler Upper Spreader Lower Weight	1		32900
Base Crane with: Front Winch Wire Rope Boom Hoist Drum Wire Rope Crawler Upper Spreader Lower Weight	1		31900
Crawler (Assembly)	2		5700
Counter Weight A	1		8700
Counter Weight B	1		6400

Weights and Dimensions of Disassembled Units

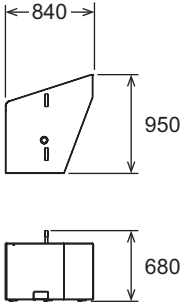
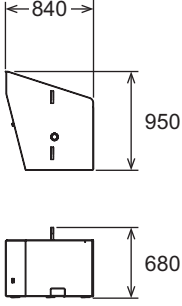
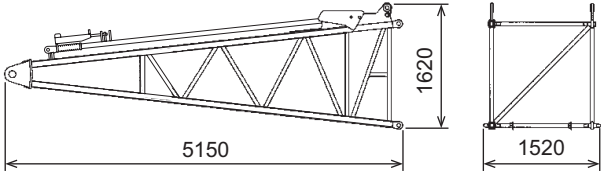
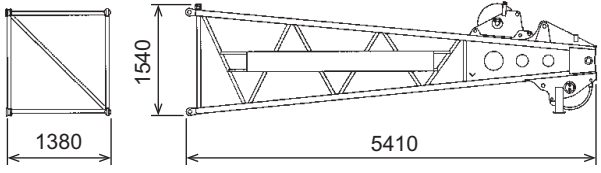
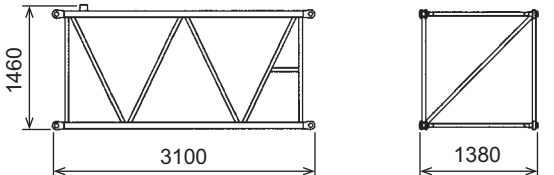
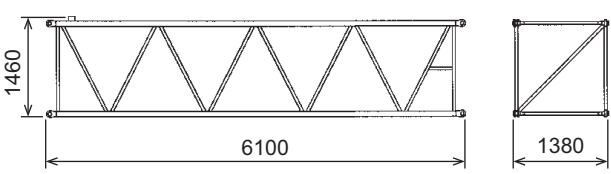
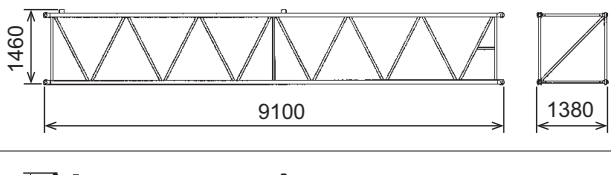
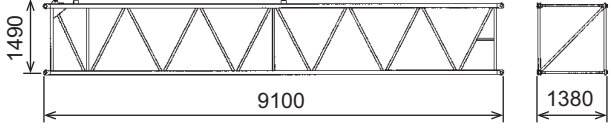
Description	Qty	Dimensions (mm)	Weight (kg)
Counter Weight C	1		1700
Counter Weight D	1		1800
Boom Base with: Connect Pin Boom Foot Pin Exclusive Crane Backstop	1		1000
Boom Top with: Pendant Rope Anti-Two Block	1		1010
3 m Boom Insert with: Connect Pin Pendant Rope	1		285
6 m Boom Insert with: Connect Pin Pendant Rope	1		460
9 m Boom Insert with: Connect Pin Pendant Rope	1		665
9m Special Boom Insert (9B) with: Connect Pin Pendant Rope	1		690

Weights and Dimensions of Disassembled Units

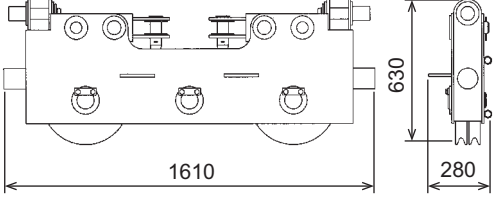
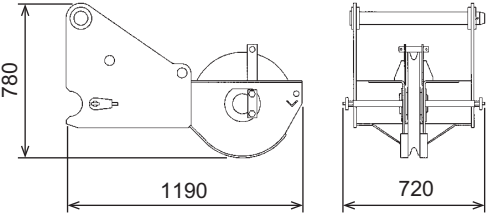
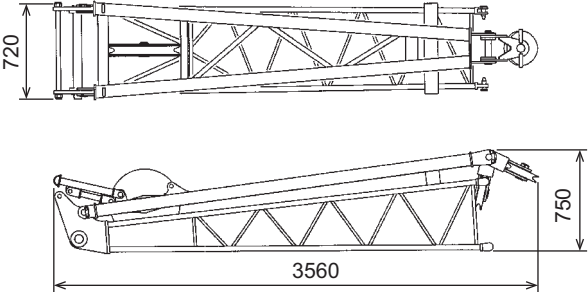
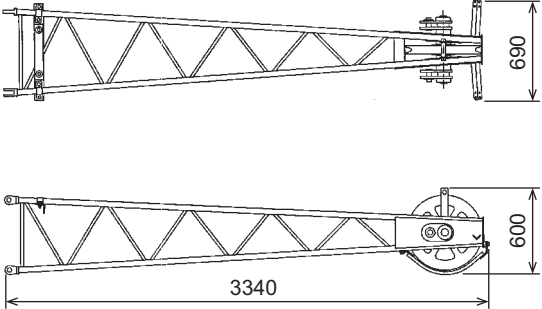
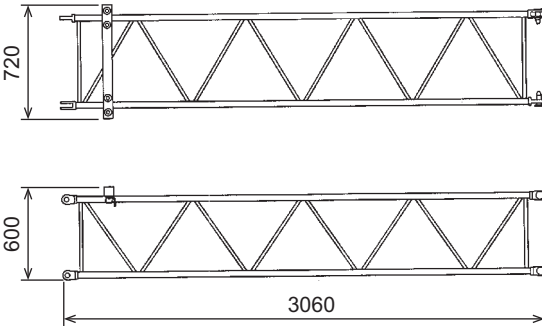
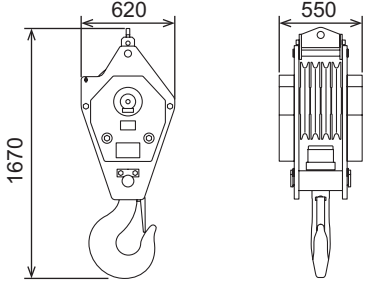
Description	Qty	Dimensions (mm)	Weight (kg)
Upper Spreader	1		260
Aux. Sheave with: Connect Pin	1		220
Crane Jib Bottom with: Connect Pin Boom Foot Pin Jib Strut Connect Pin	1		340
Jib Top	1		160
Jib Insert with: Connect Pin	1		80
55 t Hook	1		850

Weights and Dimensions of Disassembled Units

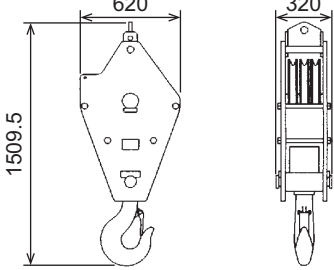
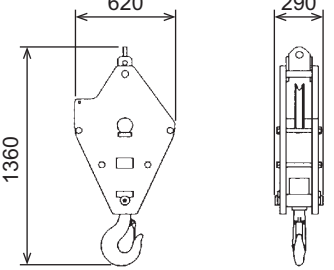
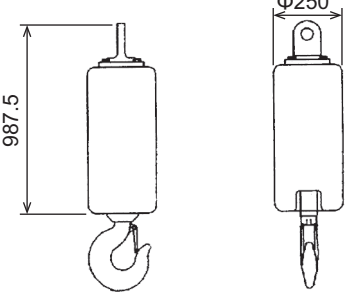
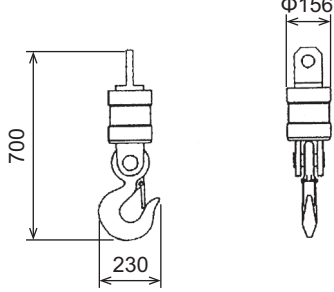
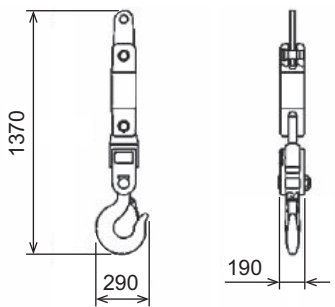
Description	Qty	Dimensions (mm)	Weight (kg)
30 t Hook	1		360
15 t Hook	1		320
6.5 t Hook	1		180
6.5 t Hook (Light Type)	1		40
6.5 t Swivel Hook	1		120

Equipment List

Standard and Optional Equipment

○: Standard ●: Optional —: No setting

Item		Crane	Clamshell
Lower Structure	760 mm Crawler Shoe	○	○
	Crawler Extension/Retraction System	○	○
	Steps	○	○
	Shoe Tension Unit (Hydraulic Hand Pump Type)	○	○
Upper Structure	Cab Up/Down Catwalk	○	○
	Under Cover (Bed Lower Surface)	○	○
	Working Light (× 2)	○	○
	Back Mirror (Left and Right)	○	○
	Central Lubrication Unit (For Gantry Axle, Turntable Bearing)	○	○
	Drum Flange Cover	○	○
	Auto Idle Stop	○	○
	Eco Winch	○	○
	Drum Mirror	●	●
	Drum Light	●	●
	Winch Rope Retainer (Front Winch)	●	●
	Winch Rope Retainer (Rear Winch)	●	●
	Catwalk (Folding Type, Left and Right)	●	●
	Catwalk (Handrails Type, Left and Right)	○ ^{*1}	○ ^{*1}
	Electric Fuel Pump	●	●
	Upper House Handrails (Folding Type)	○	○
Winch with Front and Rear Free Mechanism (φ 22 mm Band Brake Type with Brake Mode Select Switch)	○	○	
Cab	Air Conditioner	○	○
	Sunvisor	○	○
	Sunshade	○	○
	Wiper with Washer (Front Window, Cab Roof Window)	○	○
	Microphone & Loudspeaker	○	○
	AM/FM Radio (With Clock)	○	○
	Room Lamp	○	○
	Cup Holder	○	○
	24 V Power Socket (× 2)	○	○
	Floor Carpet	○	○
	Level Gauge (In Cab)	○	○
	Arm Chair Lever	○	○
	Cross Operation Lever (Lever Lock Not Attached)	● / ○ ^{*1}	● / ○ ^{*1}
	Standard Seat	○	○
	Seat with Suspension	● / ○ ^{*1}	● / ○ ^{*1}
	Front/Rear Operation Lever, Brake Pedal Permutation	●	●
	Drum Rotation Sensor (Front/Rear) ^{*2}	○	○
	Accelerator Grip	○	○
	Accelerator Pedal (Right Side)	●	●
	Speed Control Dial (Front, Rear, Swing)	○	○
	Boom Hoist Operation Pedal ^{*3}	●	●
	Swing Brake Operation Pedal ^{*3}	●	●
	Fan	●	●
Fuel Burning Heater	●	●	
Life Hammer	○	○	

*1 Europe specification machines only.

*2 Cannot be equipped when the cross operation lever.

*3 Cannot be equipped at the same time.

○: Standard ●: Optional —: No setting

Item		Crane	Clamshell
Attachment	10 m Basic Boom (Boom Base: 5 m, Boom Top: 5 m)	○	○
	3 m Boom Insert	●	●
	6 m Boom Insert	●	●
	9 m Boom Insert	●	●
	9 m Special Boom Insert (9B) ^{*4}	●	—
	Parts Set for 15m Crane Jib [6 m Basic Jib,3 m Crane Jib Insert x3, Anti-Two Block,Jib Mast]	●	—
	Parts set for Auxiliary Sheave [Auxiliary sheave,Auxiliary sheave Anti-Two Block]	●	—
	55 t Hook (4 Sheaves)	●	—
	30 t Hook (3 Sheaves)	●	—
	15 t Hook (1 Sheave)	●	—
	6.5 t Hook	●	—
6.5 t Hook (Light Type,120 kg) ^{*5}	●	—	
Wire Rope	Front Winch (φ 22)	XP IWRC 6 x WS (31)	○
		Mono Rope EP 3 x F (40)	●
		P · S (19) + 39 x P · 7	●
	Rear Winch (φ 22)	XP IWRC 6 x WS (31)	●
		Mono Rope EP 3 x F (40)	●
Boom Hoist Winch (φ 16)	XP IWRC 6 x WS (31)	○	
Safety Device	Moment Limiter (M/L)	○	
	3 Color Percentage Indicator Light	● / ○ ^{*6}	
	Gate Lock Lever	○	
	Individual Winch Operation Lever Lock (Front, Rear, Hoist, Travel) ^{*7}	○	
	Automatic Pawl Drum Lock (Boom Hoist)	○	
	Winch Pawl Lock (Front/Rear)	○	
	Lowering Limiter (Winch Drum Dead Turns Detective Device)	● / ○ ^{*6}	
	Swing Lock	○	
	Swing Alarm	○	
	Travel Alarm	○	
	Auto Slowdown (Slow Stop)	○	
	Boom Over Hoist Limiting Device	○	
	Secondary Boom Over Hoist Limiting Device	○	
	Warning Alarm	○	
	Engine Start Interlock System	○	
	Emergency Engine Stop Switch (In Cab)	○	
	Lifting Height Indication Device	○	
	Anti-Two Block	○	
	Moment Limiter (M/L) Mode Selector (In Right House)	● / ○ ^{*6}	
	Swing Neutral Free/Brake Mode Selection Switch ^{*8}	●	
	Swing Restriction Unit ^{*8,*9}	●	
	Anemometer	○	
Obstacle Lights (Fixed Light)	●		
Drum & Rear View Monitor (2 cameras)	●		
Cab Roof Window Guard	● / ○ ^{*6}		

*4 For Crane Jib.

*5 There may be cases where the hook can not be lowered by itself. Additional weight may be required.

*6 Europe specification machines only.

*7 An operation lever lock is not attached to the front, rear or hoist when the cross operation lever is installed.

*8 Cannot be canceled or add-on after ordering the machine.

*9 Swing Neutral Free/Brake Selection Switch Device and Swing Restriction Unit should be ordered as a set.

○: Standard ●: Optional —: No setting

Item		Crane	Clamshell	
Common Parts	Boom Back Stop	○	○	
	Boom Angle Sensor	○	○	
	Boom Lifting Piece	○	○	
	Boom Connect Pin Holder	○	○	
	Remote Sensing (Mobile Communication Terminal, Data Logging Device)	○	○	
	Reduction Counter Weight Specification (15.1 t/8.7 t) ^{*9}	● ^{*10}	—	
	Skywalk (With Stanchion)	●	—	
	Skywalk (Without Stanchion)	●	—	
	Boom Top Under Surface Buffer (Protector)	●	●	
	Load Table Sign (Whiteboard, Boom Base Installation)	●	●	
	Insertable Company Name Plate (Both side surfaces of the machine)	● ^{*11}	●	
	Opening/Closing/Support Rope Stopper	—	○	
	Division Type Rope Guide	●	●	
	Hydraulic Tagline (6 × Fi (29) φ 10 mm × 45 m)	● ^{*12}	○	
	Reeving Winch (4 × F (30) φ 8 mm × 250 m)	● ^{*12}	—	
	Reeving Winch Cum Hydraulic Tagline	For hydraulic tagline (6 × Fi (29) φ 10 mm × 45 m)	● ^{*12}	—
		For reeving (6 × Fi (29) φ 10 mm × 160 m)	● ^{*12}	—
	Sling Ropes for Disassembly and Assembly (For counter weights)	●	●	
Additional Spare Parts (Hydraulic Oil Filter)	●	●		
Additional Tools (Large Hammer, Crowbar, Chisel)	●	●		
Others	Standard Supplied Tools	○	○	
	Standard Spare Parts	○	○	

*10 The reduction counter weight specification can only be used for the crane specification, with the exception of the crane jib.

*11 When it chooses, the width at the time of transportation is set to not less than 3.2 m.

*12 (1) Hydraulic tagline (maximum line pull: 0.88 kN (90 kgf))

(2) Reeving winch (maximum line pull: 11.8 kN (1,200 kgf))

(3) Reeving winch cum hydraulic tagline (maximum line pull for hydraulic tagline: 1.4 kN (150 kgf)/maximum line pull for reeving winch: 2.9 kN (300 kgf))

- We are constantly improving our products and therefore reserve the right to change designs and specifications without notice.
- Units in this specification are shown under International System of Units; the figures in parenthesis are under Gravitational System of Units as old one.

Sumitomo Heavy Industries Construction Cranes Co., Ltd.

9-3, Higashi-Ueno 6-chome, Taito-ku, Tokyo 110-0015, Japan
Phone: 81-3-3845-1387 Facsimile: 81-3-3845-1394

<http://www.hsc-cranes.com>