

SCX900HD-2

GENERAL DIMENSIONS

Unit : mm

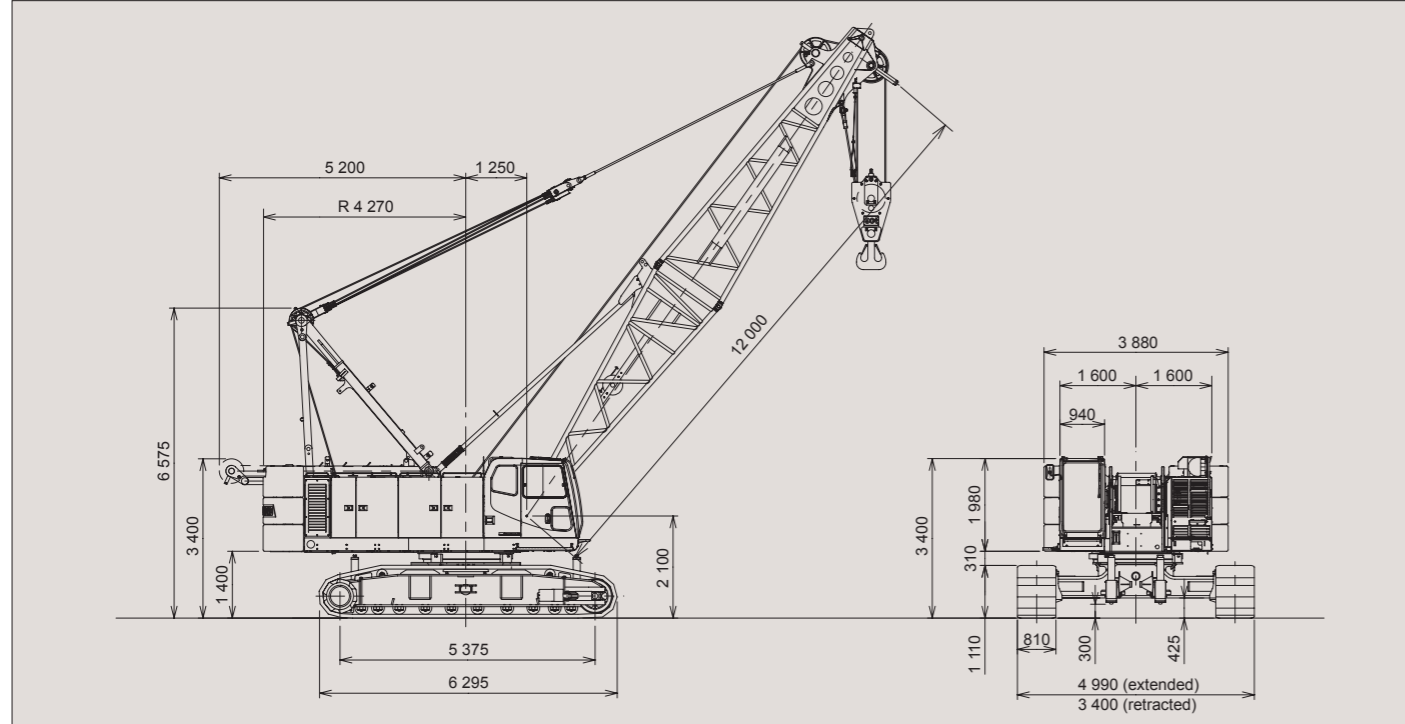

SPECIFICATIONS

		Lift crane application	Clamshell application
Max. lifting capacity	t × m	90 × 4.0	—
Basic boom length	m	12	12
Max. boom length	m	60	24
Rope line speeds ^{(*)1}	Front main drum	m / min	110
	Rear main drum	m / min	110
	Boom hoist drum	m / min	46
Slewing speed	min ⁻¹	2.5	2.5
Travel speed	high / low ^{(*)2}	2.1 / 1.2	2.1 / 1.2
Gradeability	% (°)	30 (17)	30 (17)
Engine	Make & model	Mitsubishi 6M70-TL	Mitsubishi 6M70-TL
	Rated output	kW / min ⁻¹	272 / 2 000
Ground contact pressure	kPa	96	100
Operating weight	t	85 (w / basic boom and 90 t hook block)	89 (w / basic boom and 3.0 m ³ clamshell bucket)

Notes : 1. These figures are based on drum first layer and rated engine rpm with no load, and vary under load and operating conditions (*1).
 2. Travel speed is based on flat, level and firm supporting surface, and under the conditions that no load must be applied and front-end attachment must be 12 m basic boom (*2).

•We are constantly improving our products and therefore reserve the right to change designs and specifications without notice.
 •Units in this catalog are shown under International System of Unit ; the figures in parenthesis are under Gravitational System of Units as old one.
 •Illustrations may include optional equipment and accessories, and may not include all standard equipment.

HSC throughout this catalog. "HSC CRANES" is a brand of Sumitomo Heavy Industries Construction Cranes Co., Ltd.

Address inquires to :

Sumitomo Heavy Industries Construction Cranes Co., Ltd.

9-3, Higashi-Ueno 6-chome, Taito-ku, Tokyo 110-0015, Japan
 Phone: 81-3-3845-1387 Facsimile: 81-3-3845-1394
<http://www.hsc-cranes.com>

HYDRAULIC HEAVY DUTY CRAWLER CRANE

SCX900HD-2

The New World Standard Crawler Crane





An ideal answer over a true hydraulic heavy duty crawler crane —

SCX900HD-2 just unveils.

A high excavating performance under excellent controllability at operator's will with newly developed powerful drum winches performing bigger line pull and sure break capability.

A powerful newly developed winch drums; they are certainly able to respond to any hard works under foundation jobs like hammer grabbing.

Formerly, HSC was a standard bearer of heavy duty foundation base machine, and since then HSC has been having a hard time trying energetically to develop a true foundation base machine for next generation, and it now results in seeing a epoch-making machine, SCX900HD-2 under an accumulated design technologies and field experiences of Sumitomo and Hitachi so far with design concept of "simple, refined and reliable". Thanks to customer's good and long patience, the SCX900HD-2 now unveils.

Advanced clutchless multiple wet-disc brake

**Rated line pull:
132 kN (13.5 ton)**

**Bigger width drum:
632 mm**

**High line speed:
110 m/min⁻¹**

**High power engine:
272 kW (370 PS)**

Notes: Illustrations and photos may include optional equipment and accessories, and may not include all standard equipment.
: All of photos shown in this catalog are for the sake of catalog make; if the operator is away from cab during machine operation, it is certainly required to set appropriate safety device(s) without fail.

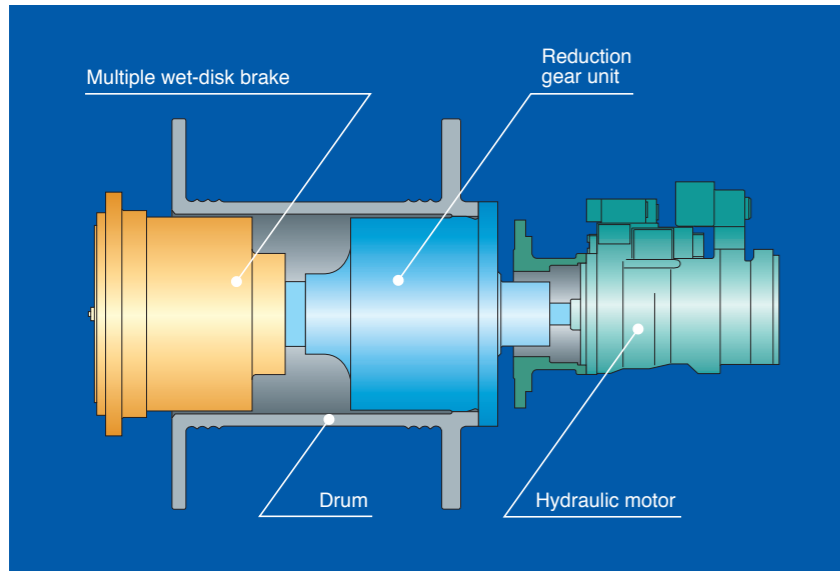

Most advanced clutchless multiple wet-disc brake

At operator's will, two main winch drum brakes will perform a constant brake pedal feeling regardless of what is load, light or heavy, and what brake pedal stroke is done from initial thru full. And, no over-heating is of course seen even under heavy duty works as a forced-oil cooling system is designed, and it results in stress-free operation.

A long-awaited machine performance from foundation job customer is —

A Clear Brake Response & Sure Brake Capability.

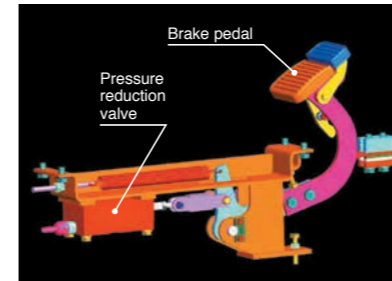
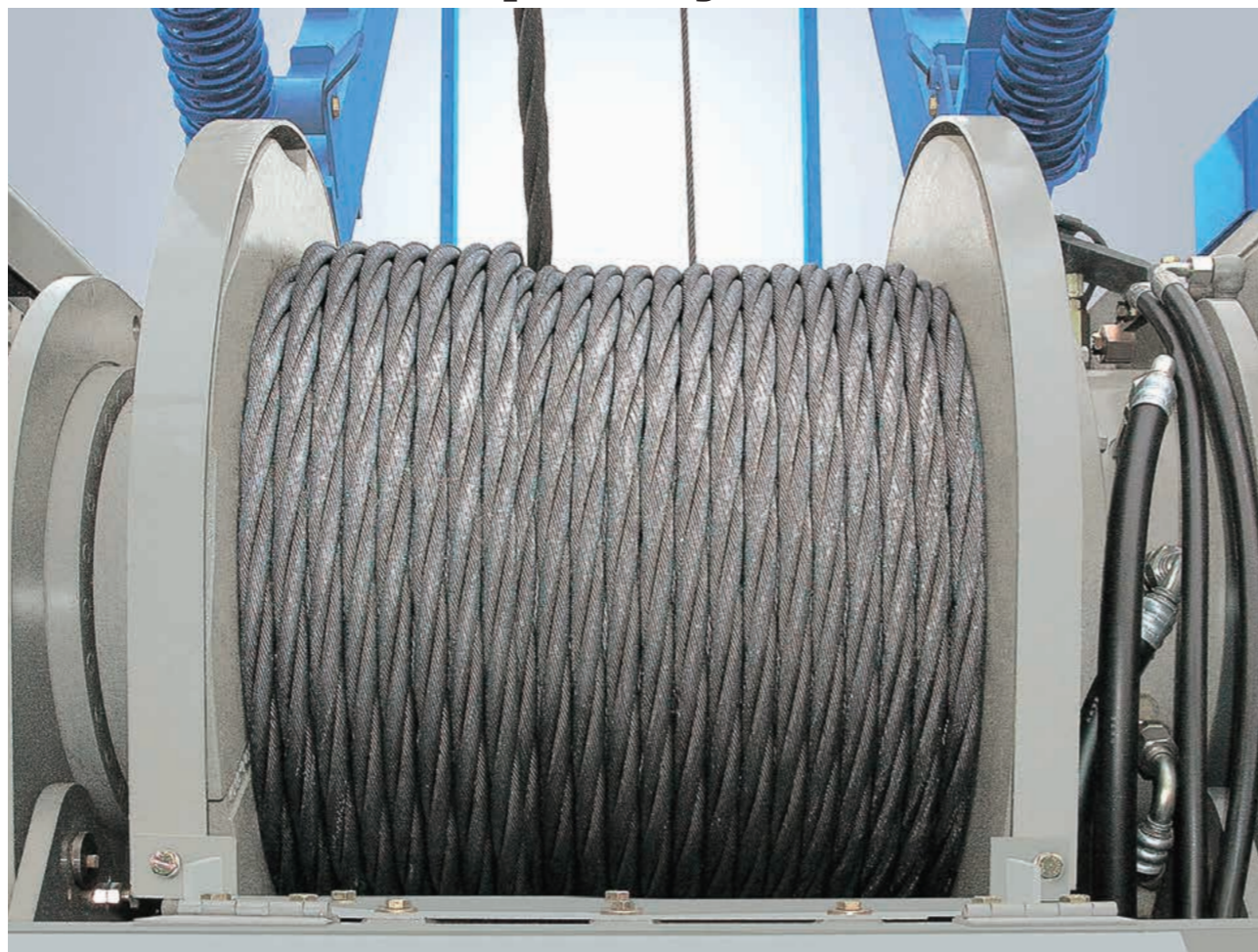

Negative brake system

With a new negative brake of spring-applied/power hydraulically-released design applying dynamic hydraulic pressure for its release control, an effective braking can be done under an extreme light foot pedalling, and it accordingly results in greatly reducing operator fatigue especially during winch free-fall operations under duty cycle applications. Further, the use of negative brake system maintains a high level of brake safety even if a hydraulic pressure drop in the circuit happens.

Free-fall mechanism

Of course, two main winch drums' free-fall function is standardized, and their rated line pull is 132 kN (13.5 ton) with 28 mm dia. cable as enough for bucket off-ground and casing tube drawing.

An optional 3rd winch drum

An 108 kN (11.0 ton) line pull is performed, and a 50 t lift can be done. And, a 2 m dia. casing driver lift and other auxiliary lift can also be done.

High power engine

A 272 kW (370 PS) engine from Mitsubishi is provided, and accordingly a bigger drum horse power (line pull by line speed) is realized under a new winch drum design with a specially-tailored power increase control system that maximizes engine output under any load condition in whole range of engine rpm.

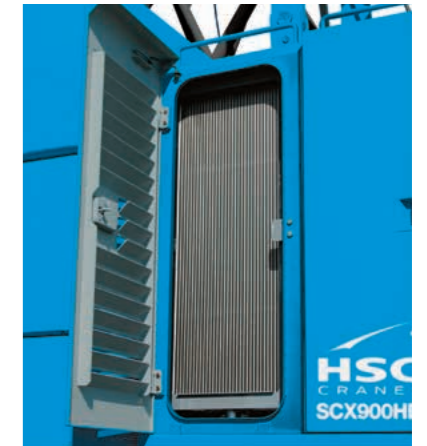

Separated oil cooler from engine radiator

Aluminum-make; located at a part of superstructure as separated from engine radiator together with an independent autocooling fan for better cooling efficiency and heat balance, and a good maintenance.





One -hand acceleration grip

Thanks to a unique grip design, an easy -precise-minute control of engine rpm and pump discharge from min. thru max. is really possible at the same time by simply twisting the grip fitted on slewing control lever.



Drum rotation sensors

Control levers of two main and boom hoist drums each fit the drum rotation sensor to let operator sense a drum rotation speed decrease/increase by a knob vibration during inching lever operation, and it results in realizing a good work performance on specific foundation jobs like "bucket off-ground", "pile initial drawing" and so on, and in performing more safety lifting works, especially in blind condition.

Brake mode change switches

On top of winch drum control levers, the said switches are fitted too for easy-and-sure change of brake mode from "automatic" to "free-fall" and vice versa.



Brake mode select key switches

On instrument panel, these are provided, and in the case that "automatic" brake mode is once set, winch drum always keeps this mode even if "free-fall" brake mode is get by the other brake mode change switch fitted on rum control levers.

To free from work stress of operator —
**Strict Design Concentration toward
 Universal Operation Controllability
 & Operator Comfort.**

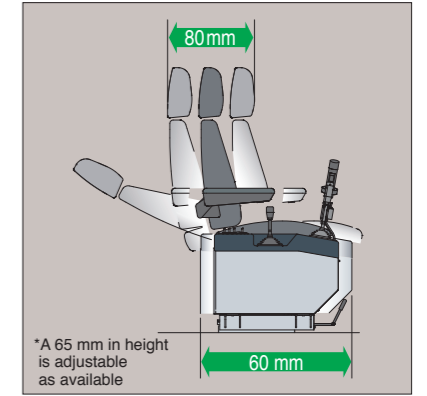

Slidable control station and operator seat

To set most of suitable operator position, both right-and left-hand control stations are designed to simultaneously slide 60 mm back and forth together with operator seat, and operator seat is able to slide 80 mm independently too. Further, a well-proportional seat design is taken to reduce operator fatigue during continuous duty cycle works.



New load moment indicator

An easy-to-read LCD graphic display panel is well designed and a reflection-less display panel is provided on a new LMI with setting ease of viewing angle. In addition, no zero-point adjustment, and data input thru interface counter-indication/message on display panel are available for easier and certain setting of operating conditions and LMI function. Of course, "present lifting load", "rated load", "load ratio", "working radius", "boom angle", "engine rpm" and so on are indicated on the LMI display panel. Further, the LMI functions that if lifting condition reaches peril zone, an intermittent warning buzzer is given operator together with a warning letter message on display panel of LMI.



Boom speed slowdown function

This function is available just before automatic stopping of boom motion at both upper and lower side limits of boom angle to prevent a shock even though control lever is still at hoisting/lowering position. This function is also available when over-loading in the case that working radius exceeds the specified one.

Front-end attachment erection mode

In the range out of crane working area, the LMI display panel automatically indicates "Now, out of crane working range" with a rigging instruction, and it is available to lift front-end att. off ground without the influence of LMI safety functions, and, after front-end att. is lifted over the range of crane working area, LMI safety function gets back automatically for safe erection work.

Function check over safety devices

The LMI is able to check whether or not safety devices like "main hook over-hoisting limiter", "boom over hoisting and lowering limiter", and "secondary boom over-hoisting limiter" is correct before operation.

Standardized safety devices other than the above

- ① Emergency engine stop switch (in cab)
- ② Lifting height indication device
- ③ Lock lever (Fool proof shut-off lever)
- ④ Automatic drum lock; boom hoist drum
- ⑤ Control lever locks
- ⑥ Slewing & travel alarm

Low emission engine

The prime mover, Mitsubishi 6M70-TL, meets Stage/Tier 3 of current emission regulation for off-road diesel engine in Europe, USA, and Japan.

Environmental management

Under our own strict idea, it is being done and is taken in any way, any time and anywhere on manufacture of products.

For gentle and lovely machine to human being and nature —
Severe Consideration over Safety
First and Environmental Management.



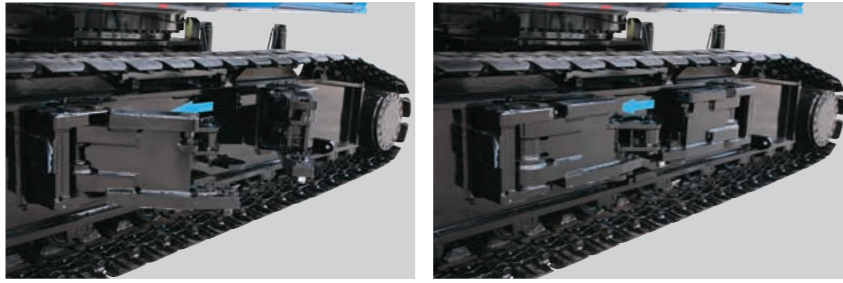

Folding type axle beam ends

Longer lower frame axle beams with folding type ends are designed, and these four (4) ends reach up to axle box end of crawler side frames for better fitting between axle beams and crawler side frames. And, it is able to eliminate their assembling/disassembling, and axle beam-end pins can easily be pulled up and down from outside.

Counterweights

"Hook-on" design is taken for their mounting on upper revolving frame, and "horizontally-split" design is also taken to load boom extension(s) onto counterweights when transport.

Optional rigid guard

A detachable-ease rigid guard is optionally available i/o standard, and it is possible to eliminate to take cable out of drum when machine disassembling for transport in the case of a special cable-end with lug.

Gantry

A-frame type; raised and lowered by power hydraulic cylinders for assembling/disassembling ease.

To get fast assembling/disassembling and transport —

Sincere Attention to High Cost Efficiency.

